

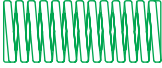









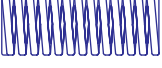

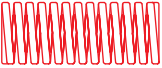

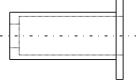

# Springs

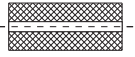

## WIRE SPRINGS DIN ISO 10243

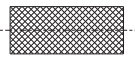
<b>General Informations</b>			01	
<b>S11</b>			for light loads	
<b>R11</b>				02
<b>S21</b>			for medium loads	
<b>R21</b>				05
<b>S26</b>			for heavy loads	
<b>R26</b>				08
<b>S36</b>			for extra-heavy loads	11
<b>FHx</b>			Retainer	13

## ELASTOMER SPRINGS

<b>S66</b>		Hollow rod	14
<b>S67</b>			
<b>S68</b>		Solid rod	14
<b>S69</b>			
<b>S50</b>		Elastomer springs 70 - Shore	15
<b>S55</b>		Elastomer springs 90 Shore	17

## ACCESSORIES

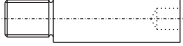
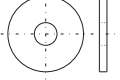
<b>S60</b>		Guide shafts	19
<b>S65</b>		Washers	19

## ASSEMBLY INSTRUCTIONS

20

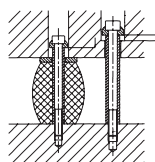

# WIRE SPRINGS - GENERAL INFORMATIONS

DIN ISO 10243 - Standard

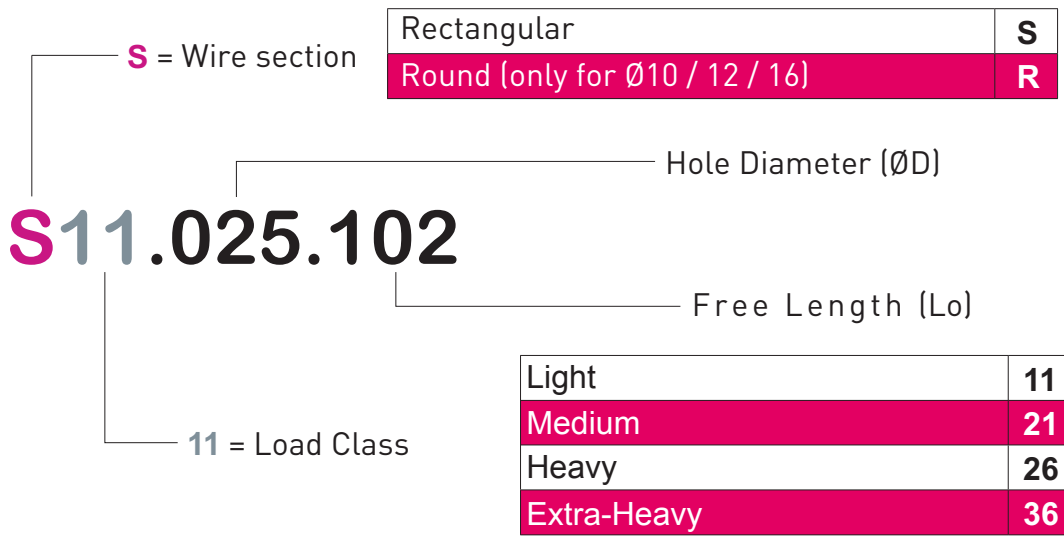

- Lo** = Free length
- S3** = Maximum operating deflection
- S2** = Total deflection recommended for average life
- S1** = Total deflection recommended for long life

(1) - The right sizing of the pre-load value is essential to satisfy a long life to the springs.

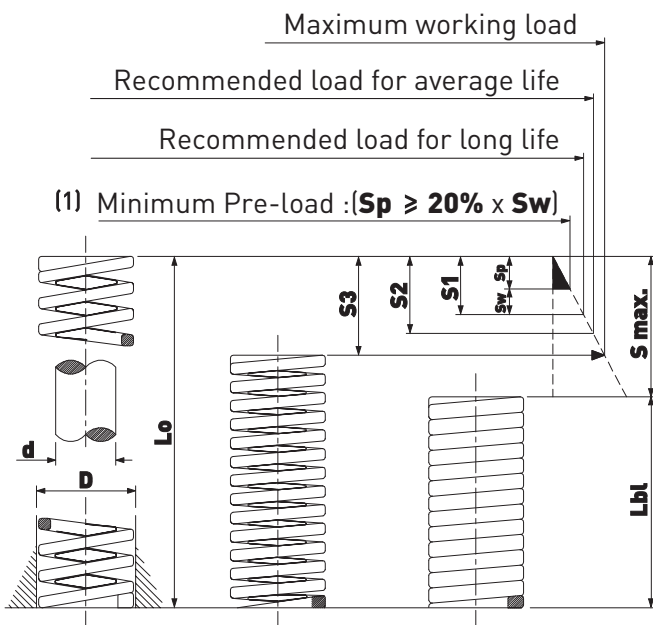

Load Class	11	21	26	36
<b>S1</b> Total deflection recommended for long life	25% of Lo	25% of Lo	20% of Lo	17% of Lo
<b>S2</b> Total deflection recommended for average life	30% of Lo	30% of Lo	25% of Lo	20% of Lo
<b>S3</b> Maximum operating deflection	40% of Lo	37,5% of Lo	30% of Lo	25% of Lo

Lo : Free length

- Sw** = Effective deflection
  - Sp** = Pre-load
  - Lbl** = Total length solid condition
- $$Sw + Sp \leq S3$$

We select the best steels (Chrome Vanadium Silicon Steels) to manufacture our springs, the same supplied for automotive valve springs.

We use drawn wire which guarantees best characteristics.

We manufacture our springs according to a strict procedure : after forming and heat treatment, we carry out shot peening to improve more the fatigue resistance.

We carefully grind the 2 faces to obtain a perfect perpendicularity at each step we carry out a strict inspection to guarantee you the greatest life of our springs.

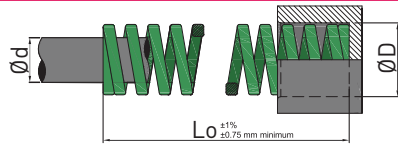

Diameters : 10 to 20mm  
Rectangular wire



Hole Ø mm	Rod Ø mm	Free length mm	Reference	RATE (daN) required to deflect 1 mm	LOAD TABLE							
					S1 Total deflection recommended for long life (25% of Lo)		S2 Total deflection recommended for average life (30% of Lo)		S3 Maximum operating deflection (40% of Lo)		Total travel to solid	
					Load daN	Deflect. mm	Load daN	Deflect. mm	Load daN	Deflect. mm	Load daN	Deflect. mm
D	d	Lo	C	C	Load daN	Deflect. mm	Load daN	Deflect. mm	Load daN	Deflect. mm	Load daN	Deflect. mm
10	5	25	S11.010.025	1,00	6,25	6,25	7,5	7,5	10,2	10,2	14,3	14,3
		32	S11.010.032	0,85	6,8	8	8,16	9,6	10,6	12,5	15,6	18,3
		38	S11.010.038	0,68	6,46	9,5	7,48	11	10,2	15	15,0	22
		44	S11.010.044	0,60	6,6	11	7,8	13	10,8	18	15,6	26
		51	S11.010.051	0,50	6,5	13	7,5	15	10,0	20	14,5	29
		64	S11.010.064	0,43	6,88	16	8,17	19	10,8	25	16,3	38
		76	S11.010.076	0,32	6,08	19	7,36	23	9,60	30	14,7	46
305	S11.010.305	0,11	8,36	76	10,01	91	13,4	122	19,6	178		
12,5	6,3	25	S11.012.025	1,79	11,09	6,2	13,42	7,5	18,3	10,2	24,3	13,6
		32	S11.012.032	1,64	13,12	8	15,74	9,6	20,5	12,5	30,0	18,3
		38	S11.012.038	1,36	12,92	9,5	14,96	11	20,4	15	29,9	22
		44	S11.012.044	1,21	13,31	11	15,73	13	21,8	18	31,5	26
		51	S11.012.051	1,14	14,82	13	17,1	15	22,8	20	34,2	30
		64	S11.012.064	0,93	14,88	16	17,67	19	23,3	25	35,3	38
		76	S11.012.076	0,71	13,49	19	16,33	23	21,3	30	31,2	44
89	S11.012.089	0,54	11,88	22	14,58	27	19,4	36	28,1	52		
305	S11.012.305	0,14	10,64	76	12,74	91	17,1	122	24,5	175		
16	8	25	S11.016.025	2,34	14,5	6,2	17,55	7,5	23,9	10,2	31,1	13,3
		32	S11.016.032	2,29	18,32	8	21,98	9,6	28,6	12,5	37,6	16,4
		38	S11.016.038	1,93	18,33	9,5	21,23	11	29,0	15	40,5	21
		44	S11.016.044	1,71	18,81	11	22,23	13	30,8	18	42,8	25
		51	S11.016.051	1,57	20,41	13	23,55	15	31,4	20	45,5	29
		64	S11.016.064	1,01	16,16	16	19,19	19	25,3	25	37,4	37
		76	S11.016.076	1,00	19,0	19	23	23	30,0	30	44,0	44
89	S11.016.089	0,86	18,92	22	23,22	27	30,1	35	45,6	53		
102	S11.016.102	0,78	20,28	26	24,18	31	32,0	41	47,6	61		
305	S11.016.305	0,25	19,0	76	22,75	91	30,5	122	46,0	184		
20	10	25	S11.020.025	5,5	35	6,2	42	7,5	57	10,2	73	13
		32	S11.020.032	4,2	34	8	41	9,6	54	12,5	69	16
		38	S11.020.038	3,3	32	9,5	37	11	51	15	65	19
		44	S11.020.044	2,77	31	11	37	13	51	18	64	23
		51	S11.020.051	2,45	32	13	37	15	50	20	64	26
		64	S11.020.064	1,90	31	16	37	19	49	25	62	32
		76	S11.020.076	1,61	31	19	37	23	48	30	62	40
		89	S11.020.089	1,34	30	22	36	27	47	35	62	46
		102	S11.020.102	1,18	31	26	37	31	48	41	62	53
		115	S11.020.115	1,04	30	29	36	35	48	46	62	60
		127	S11.020.127	0,93	30	32	35	38	47	51	62	67
		140	S11.020.140	0,85	30	35	36	42	48	56	62	73
		152	S11.020.152	0,79	30	38	36	46	48	61	62	81
305	S11.020.305	0,38	29	76	35	91	46	122	61	162		

# LIGHT LOAD SPRINGS

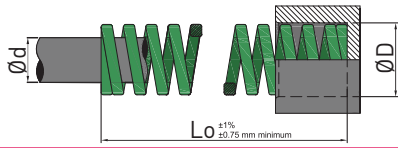

Diameters : 25 to 63mm  
Rectangular wire



Hole Ø mm	Rod Ø mm	Free length mm	Reference	RATE (daN) required to deflect 1 mm	LOAD TABLE									
					S1 Total deflection recommended for long life (25% of Lo)		S2 Total deflection recommended for average life (30% of Lo)		S3 Maximum operating deflection (40% of Lo)		Total travel to solid			
					Load daN	Deflect. mm	Load daN	Deflect. mm	Load daN	Deflect. mm	Load daN	Deflect. mm		
25	12,5	25	S11.025.025	10,7	66	6,2	80	7,5	109	10,2	139	13		
		32	S11.025.032	8,1	65	8	78	9,6	101	12,5	130	16		
		38	S11.025.038	6,5	62	9,5	72	11	98	15	124	19		
		44	S11.025.044	5,3	58	11	69	13	95	18	122	23		
		51	S11.025.051	4,6	60	13	69	15	92	20	115	25		
		64	S11.025.064	3,6	58	16	68	19	90	25	112	31		
		76	S11.025.076	2,92	56	19	67	23	88	30	112	39		
		89	S11.025.089	2,46	54	22	66	27	86	35	112	46		
		102	S11.025.102	2,12	55	26	66	31	87	41	110	52		
		115	S11.025.115	1,87	54	29	65	35	86	46	110	59		
		127	S11.025.127	1,67	53	32	63	38	85	51	110	66		
		140	S11.025.140	1,52	53	35	64	42	85	56	112	74		
		152	S11.025.152	1,40	53	38	64	46	85	61	110	80		
		178	S11.025.178	1,20	53	44	64	53	85	71	110	93		
		203	S11.025.203	1,05	53	51	64	61	85	81	110	107		
		305	S11.025.305	0,70	53	76	64	91	85	122	110	160		
32	16	38	S11.032.038	10,10	96	9,5	111	11	152	15	192	19		
		44	S11.032.044	8,3	91	11	108	13	149	18	183	22		
		51	S11.032.051	7,1	92	13	107	15	142	20	178	25		
		64	S11.032.064	5,5	88	16	105	19	138	25	176	32		
		76	S11.032.076	4,6	87	19	106	23	138	30	175	39		
		89	S11.032.089	3,9	86	22	105	27	137	35	175	45		
		102	S11.032.102	3,4	88	26	105	31	139	41	175	52		
		115	S11.032.115	3,0	87	29	105	35	138	46	174	58		
		127	S11.032.127	2,62	84	32	100	38	134	51	170	65		
		140	S11.032.140	2,38	83	35	100	42	133	56	171	72		
		152	S11.032.152	2,19	83	38	101	46	134	61	170	78		
		178	S11.032.178	1,82	80	44	96	53	129	71	165	88		
		203	S11.032.203	1,59	81	51	97	61	129	81	165	104		
		254	S11.032.254	1,25	80	64	95	76	128	102	163	130		
		305	S11.032.305	1,04	79	76	95	91	127	122	161	155		
		40	20	51	S11.040.051	10,6	138	13	159	15	212	20	265	25
64	S11.040.064			8,0	128	16	152	19	200	25	256	32		
76	S11.040.076			6,6	125	19	152	23	198	30	250	38		
89	S11.040.089			5,6	123	22	151	27	196	35	250	45		
102	S11.040.102			4,8	125	26	149	31	197	41	245	51		
115	S11.040.115			4,2	122	29	147	35	193	46	243	58		
127	S11.040.127			3,8	122	32	144	38	194	51	243	65		
140	S11.040.140			3,4	119	35	143	42	190	56	241	71		
152	S11.040.152			3,1	118	38	143	46	189	61	241	78		
178	S11.040.178			2,6	114	44	138	53	185	71	240	92		
203	S11.040.203			2,3	117	51	140	61	186	81	240	105		
254	S11.040.254			1,80	115	64	137	76	184	102	236	131		
305	S11.040.305			1,48	112	76	135	91	181	122	226	157		
50	25			64	S11.050.064	15,7	251	16	298	19	393	25	502	32
				76	S11.050.076	12,6	239	19	290	23	378	30	491	39
				89	S11.050.089	10,5	231	22	284	27	368	35	473	45
		102	S11.050.102	9,0	234	26	279	31	369	41	468	52		
		115	S11.050.115	7,8	226	29	273	35	359	46	455	58		
		127	S11.050.127	7,0	224	32	266	38	357	51	455	65		
		140	S11.050.140	6,3	221	35	265	42	353	56	446	72		
		152	S11.050.152	5,7	217	38	262	46	348	61	445	78		
		178	S11.050.178	4,8	211	44	254	53	341	71	441	92		
		203	S11.050.203	4,2	214	51	256	61	340	81	437	104		
		254	S11.050.254	3,3	211	64	251	76	337	102	429	130		
		305	S11.050.305	2,7	205	76	246	91	329	122	421	156		
		63	38	76	S11.063.076	19,3	367	19	444	23	579	30	733	38
				89	S11.063.089	15,8	348	22	427	27	553	35	695	44
				102	S11.063.102	13,4	348	26	415	31	549	41	670	50
				115	S11.063.115	11,6	336	29	406	35	534	46	661	57
127	S11.063.127			10,2	326	32	388	38	520	51	653	64		
152	S11.063.152			8,4	319	38	386	46	512	61	638	76		
178	S11.063.178			7,0	308	44	371	53	497	71	623	89		
203	S11.063.203			6,0	306	51	366	61	486	81	612	102		
254	S11.063.254			4,7	301	64	357	76	479	102	592	126		
305	S11.063.305			3,9	296	76	355	91	476	122	592	152		

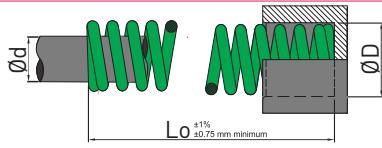

Diameters : 10 to 16mm  
Round wire



Hole Ø mm	Rod Ø mm	Free length mm	Reference	RATE (daN) required to deflect 1 mm	LOAD TABLE							
					S1 Total deflection recommended for long life (25% of Lo)		S2 Total deflection recommended for average life (30% of Lo)		S3 Maximum operating deflection (40% of Lo)		Total travel to solid	
					Load daN	Deflect. mm	Load daN	Deflect. mm	Load daN	Deflect. mm	Load daN	Deflect. mm
<b>D</b>	<b>d</b>	<b>Lo</b>	<b>C</b>									
<b>10</b>	<b>5</b>	25	R11.010.025	0,45	2,8	6,2	3,4	7,5	4,6	10,2	5,8	13
		32	R11.010.032	0,35	2,8	8	3,4	9,6	4,4	12,5	5,6	16
		38	R11.010.038	0,28	2,7	9,5	3,1	11	4,2	15	5,6	20
		44	R11.010.044	0,24	2,6	11	3,1	13	4,3	18	5,6	23
		51	R11.010.051	0,21	2,7	13	3,1	15	4,2	20	5,6	27
		64	R11.010.064	0,16	2,6	16	3	19	4	25	5,5	34
		76	R11.010.076	0,13	2,5	19	3	23	3,9	30	5,3	40
305	R11.010.305	0,03	2,3	76	2,7	91	3,7	122	4,9	163		
<b>12,5</b>	<b>6,3</b>	25	R11.012.025	0,89	5,5	6,2	6,7	7,5	9,1	10,2	11,6	13
		32	R11.012.032	0,67	5,4	8	6,4	9,6	8,4	12,5	11,4	17
		38	R11.012.038	0,55	5,2	9,5	6,1	11	8,3	15	11	20
		44	R11.012.044	0,46	5,1	11	6	13	8,3	18	10,6	23
		51	R11.012.051	0,39	5,1	13	5,9	15	7,8	20	10,5	27
		64	R11.012.064	0,30	4,8	16	5,7	19	7,5	25	10,5	35
		76	R11.012.076	0,25	4,8	19	5,7	23	7,5	30	10,3	41
89	R11.012.089	0,21	4,6	22	5,7	27	7,6	36	10,3	49		
305	R11.012.305	0,06	4,6	76	5,5	91	7,3	122	10	166		
<b>16</b>	<b>8</b>	25	R11.016.025	1,79	11,1	6,2	13,4	7,5	18,3	10,2	23	13
		32	R11.016.032	1,34	10,7	8	12,9	9,6	16,8	12,5	21	16
		38	R11.016.038	1,06	10,1	9,5	11,7	11	15,9	15	21	20
		44	R11.016.044	0,87	9,6	11	11,3	13	15,7	18	20	23
		51	R11.016.051	0,76	9,9	13	11,4	15	15,2	20	20	27
		64	R11.016.064	0,59	9,4	16	11,2	19	14,8	25	20	34
		76	R11.016.076	0,48	9,1	19	11	23	14,4	30	19,7	41
		89	R11.016.089	0,40	8,8	22	10,8	27	14	35	19,6	49
		102	R11.016.102	0,35	9,1	26	10,8	31	14,3	41	19,6	56
305	R11.016.305	0,11	8,4	76	10	91	13,4	122	18,7	170		



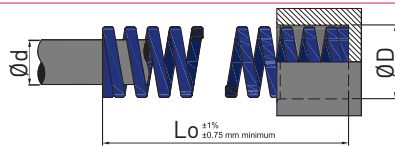

Diameters : 10 to 20mm  
Rectangular wire



Hole Ø mm	Rod Ø mm	Free length mm	Reference	RATE (daN) required to deflect 1 mm	LOAD TABLE							
					S1 Total deflection recommended for long life (25% of Lo)		S2 Total deflection recommended for average life (30% of Lo)		S3 Maximum operating deflection (37,5% of Lo)		Total travel to solid	
					Load daN	Deflect. mm	Load daN	Deflect. mm	Load daN	Deflect. mm	Load daN	Deflect. mm
<b>D</b>	<b>d</b>	<b>Lo</b>	<b>C</b>									
10	5	25	S21.010.025	1,60	9,92	6,2	12,0	7,5	15,0	9,4	18,6	11,6
		32	S21.010.032	1,30	10,4	8	12,48	9,6	15,6	12	20,7	15,9
		38	S21.010.038	1,19	11,30	9,5	13,09	11	16,7	14	23,1	19,4
		44	S21.010.044	1,03	11,33	11	13,39	13	17,0	16,5	23,7	23
		51	S21.010.051	0,89	11,57	13	13,35	15	16,9	19	23,1	26
		64	S21.010.064	0,75	12,0	16	14,25	19	18,0	24	24,8	33
		76	S21.010.076	0,53	10,07	19	12,19	23	14,8	28	21,2	40
		305	S21.010.305	0,16	12,16	76	14,56	91	18,2	114	24,6	154
12,5	6,3	25	S21.012.025	3,00	18,6	6,2	22,5	7,5	28,2	9,4	38,1	12,7
		32	S21.012.032	2,48	19,84	8	23,8	9,6	29,8	12	39,9	16,1
		38	S21.012.038	2,14	20,33	9,5	23,54	11	30,0	14	42,6	19,9
		44	S21.012.044	1,85	20,35	11	24,05	13	30,5	16,5	42,6	23
		51	S21.012.051	1,55	20,15	13	23,25	15	29,5	19	41,9	27
		64	S21.012.064	1,21	19,36	16	22,99	19	29,0	24	39,9	33
		76	S21.012.076	1,02	19,38	19	23,46	23	28,6	28	39,8	39
		89	S21.012.089	0,84	18,48	22	22,68	27	27,7	33	38,6	46
305	S21.012.305	0,21	15,96	76	19,11	91	23,9	114	33,8	161		
16	8	25	S21.016.025	4,94	30,62	6,2	37,05	7,5	46,4	9,4	55,8	11,3
		32	S21.016.032	3,71	29,68	8	35,61	9,6	44,5	12	50,5	13,6
		38	S21.016.038	3,39	32,2	9,5	37,29	11	47,5	14	59,7	17,6
		44	S21.016.044	3,00	33,0	11	39,0	13	49,5	16,5	63,0	21
		51	S21.016.051	2,64	34,32	13	39,6	15	50,2	19	66,0	25
		64	S21.016.064	2,05	32,8	16	38,95	19	49,2	24	63,6	31
		76	S21.016.076	1,78	33,82	19	40,94	23	49,8	28	67,6	38
		89	S21.016.089	1,52	33,44	22	41,04	27	50,2	33	68,4	45
102	S21.016.102	1,35	35,1	26	41,85	31	51,3	38	70,2	52		
305	S21.016.305	0,48	36,48	76	43,68	91	54,9	114	73,4	153		
20	10	25	S21.020.025	9,02	55,9	6,2	67,6	7,5	84,8	9,4	99	11
		32	S21.020.032	6,67	53,4	8	64	9,6	80	12	90	13
		38	S21.020.038	5,48	52,1	9,5	60,3	11	76,7	14	88	16
		44	S21.020.044	4,45	49	11	57,9	13	73,4	16,5	85	19
		51	S21.020.051	3,94	51,2	13	59,1	15	74,9	19	83	21
		64	S21.020.064	3,03	48,5	16	57,6	19	72,7	24	82	27
		76	S21.020.076	2,49	47,3	19	57,3	23	69,7	28	82	33
		89	S21.020.089	2,14	47,1	22	57,8	27	70,6	33	82	39
		102	S21.020.102	1,84	47,8	26	57	31	69,9	38	81	44
		115	S21.020.115	1,63	47,3	29	57	35	70,1	43	80	49
		127	S21.020.127	1,46	46,7	32	55,5	38	70,1	48	80	55
		140	S21.020.140	1,32	46	35	55	42	69	52	80	61
		152	S21.020.152	1,21	46	38	55,7	46	69	57	80	66
		305	S21.020.305	0,61	46,4	76	55,5	91	69,5	114	80	136

# MEDIUM LOAD SPRINGS



Diameters : 25 to 63mm  
Rectangular wire

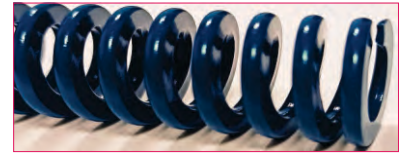

Hole Ø mm	Rod Ø mm	Free length mm	Reference	RATE (daN) required to deflect 1 mm	LOAD TABLE							
					S1 Total deflection recommended for long life (25% of Lo)		S2 Total deflection recommended for average life (30% of Lo)		S3 Maximum operating deflection (37,5% of Lo)		Total travel to solid	
					Load daN	Deflect. mm	Load daN	Deflect. mm	Load daN	Deflect. mm	Load daN	Deflect. mm
<b>25</b>	<b>12,5</b>	25	S21.025.025	16,7	104	6,2	125	7,5	157	9,4	184	11
		32	S21.025.032	12,5	100	8	120	9,6	150	12	170	13
		38	S21.025.038	9,9	94	9,5	109	11	139	14	158	16
		44	S21.025.044	8,3	91	11	108	13	137	16,5	158	19
		51	S21.025.051	7,2	94	13	108	15	137	19	156	21
		64	S21.025.064	5,5	88	16	105	19	132	24	151	27
		76	S21.025.076	4,5	86	19	104	23	126	28	148	33
		89	S21.025.089	3,8	84	22	103	27	125	33	148	39
		102	S21.025.102	3,3	86	26	102	31	125	38	145	44
		115	S21.025.115	2,91	84	29	102	35	125	43	145	60
		127	S21.025.127	2,63	84	32	100	38	126	48	145	66
		140	S21.025.140	2,36	83	35	99	42	123	52	149	63
		152	S21.025.152	2,17	82	38	100	46	124	57	145	67
		178	S21.025.178	1,84	81	44	98	53	123	67	145	79
		203	S21.025.203	1,60	82	51	98	61	122	76	144	90
		305	S21.025.305	1,05	80	76	96	91	120	114	142	135
<b>32</b>	<b>16</b>	38	S21.032.038	16,6	158	9,5	183	11	232	14	266	16
		44	S21.032.044	13,6	150	11	177	13	224	16,5	258	19
		51	S21.032.051	11,6	151	13	174	15	220	19	244	21
		64	S21.032.064	8,8	141	16	167	19	211	24	238	27
		76	S21.032.076	7,1	135	19	163	23	199	28	227	32
		89	S21.032.089	6,0	132	22	162	27	198	33	222	37
		102	S21.032.102	5,2	135	26	161	31	198	38	222	43
		115	S21.032.115	4,6	133	29	161	35	198	43	222	49
		127	S21.032.127	4,2	134	32	160	38	202	48	222	55
		140	S21.032.140	3,7	130	35	155	42	192	52	222	60
		152	S21.032.152	3,4	129	38	156	46	194	57	222	66
		178	S21.032.178	2,91	128	44	154	53	195	67	222	77
		203	S21.032.203	2,52	129	51	154	61	192	76	222	88
		254	S21.032.254	2,00	128	64	152	76	190	95	220	110
		305	S21.032.305	1,66	126	76	151	91	189	114	220	133
<b>40</b>	<b>20</b>	51	S21.040.051	17,1	222	13	257	15	325	19	359	21
		64	S21.040.064	12,9	206	16	245	19	310	24	335	26
		76	S21.040.076	10,5	200	19	242	23	294	28	335	32
		89	S21.040.089	8,8	194	22	238	27	290	33	326	37
		102	S21.040.102	7,6	198	26	236	31	289	38	326	43
		115	S21.040.115	6,7	194	29	235	35	288	43	322	48
		127	S21.040.127	6,0	192	32	228	38	288	48	322	54
		140	S21.040.140	5,4	189	35	227	42	281	52	319	59
		152	S21.040.152	4,9	186	38	225	46	279	57	318	65
		178	S21.040.178	4,2	185	44	223	53	281	67	318	76
		203	S21.040.203	3,6	184	51	220	61	274	76	315	87
		254	S21.040.254	2,89	185	64	220	76	275	95	315	110
		305	S21.040.305	2,38	181	76	217	91	271	114	312	131
<b>50</b>	<b>25</b>	64	S21.050.064	21,2	339	16	403	19	509	24	566	27
		76	S21.050.076	16,7	317	19	384	23	468	28	532	32
		89	S21.050.089	14,0	308	22	378	27	462	33	525	37
		102	S21.050.102	12,2	317	26	378	31	464	38	525	43
		115	S21.050.115	10,7	310	29	375	35	460	43	525	49
		127	S21.050.127	9,5	304	32	361	38	456	48	513	54
		140	S21.050.140	8,6	301	35	361	42	447	52	507	59
		152	S21.050.152	7,8	296	38	359	46	445	57	508	66
		178	S21.050.178	6,6	290	44	350	53	442	67	506	77
		203	S21.050.203	5,7	291	51	348	61	433	76	506	88
		229	S21.050.229	5,1	291	57	352	69	439	86	506	100
		254	S21.050.254	4,6	294	64	350	76	437	95	506	117
		305	S21.050.305	3,8	289	76	346	91	433	114	504	134
<b>63</b>	<b>38</b>	76	S21.063.076	30,4	578	19	699	23	851	28	973	32
		89	S21.063.089	25,0	550	22	675	27	825	33	950	38
		102	S21.063.102	21,2	551	26	657	31	806	38	933	44
		115	S21.063.115	18,6	539	29	651	35	800	43	930	50
		127	S21.063.127	16,4	525	32	623	38	787	48	918	56
		152	S21.063.152	13,3	505	38	612	46	758	57	891	67
		178	S21.063.178	11,2	493	44	594	53	750	67	874	78
		203	S21.063.203	9,6	490	51	586	61	730	76	865	90
		229	S21.063.229	8,5	485	57	587	69	731	86	865	102
		254	S21.063.254	7,7	493	64	585	76	732	95	865	115
		305	S21.063.305	6,3	479	76	573	91	718	114	865	138

1 daN = 1.0197 kg

Note: Need for internal guide (Lo ≥ 4xD)



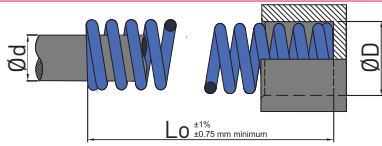

Diameters : 10 to 16mm  
Round wire



Hole Ø mm	Rod Ø mm	Free length mm	Reference	RATE (daN) required to deflect 1 mm	LOAD TABLE							
					S1 Total deflection recommended for long life (25% of Lo)		S2 Total deflection recommended for average life (30% of Lo)		S3 Maximum operating deflection (37,5% of Lo)		Total travel to solid	
					Load daN	Deflect. mm	Load daN	Deflect. mm	Load daN	Deflect. mm	Load daN	Deflect. mm
<b>D</b>	<b>d</b>	<b>Lo</b>	<b>C</b>									
<b>10</b>	<b>5</b>	25	R21.010.025	1,26	7,8	6,2	9,5	7,5	11,8	9,4	13	11
		32	R21.010.032	0,98	7,8	8	9,4	9,6	11,8	12	12,8	13
		38	R21.010.038	0,79	7,5	9,5	8,7	11	11,1	14	12,6	16
		44	R21.010.044	0,66	7,3	11	8,6	13	10,9	16,5	12,5	19
		51	R21.010.051	0,57	7,4	13	8,6	15	10,8	19	12,2	21
		64	R21.010.064	0,45	7,2	16	8,6	19	10,8	24	12,2	27
		76	R21.010.076	0,37	7,0	19	8,5	23	10,4	28	12,2	33
		305	R21.010.305	0,09	6,8	76	8,2	91	10,3	114	12,2	136
<b>12,5</b>	<b>6,3</b>	25	R21.012.025	2,28	14,1	6,2	17,1	7,5	21,4	9,4	23	11
		32	R21.012.032	1,75	14	8	16,8	9,6	21	12	22,8	13
		38	R21.012.038	1,43	13,6	9,5	15,7	11	20	14	22,8	16
		44	R21.012.044	1,18	13	11	15,3	13	19,5	16,5	22,5	19
		51	R21.012.051	1,02	13,3	13	15,3	15	19,4	19	22,4	22
		64	R21.012.064	0,79	12,6	16	15	19	19	24	22,1	28
		76	R21.012.076	0,65	12,4	19	15	23	18,2	28	22	34
		89	R21.012.089	0,55	12,1	22	14,9	27	18,2	33	22,6	41
305	R21.012.305	0,15	11,4	76	13,7	91	17,1	114	21,6	144		
<b>16</b>	<b>8</b>	25	R21.016.025	3,38	20,6	6,2	25,4	7,5	31,8	9,4	33,8	11
		32	R21.016.032	2,50	20	8	24	9,6	30	12	32,8	13
		38	R21.016.038	2,01	19,1	9,5	22,1	11	28,1	14	32,2	16
		44	R21.016.044	1,67	18,4	11	21,7	13	27,6	16,5	30,9	19
		51	R21.016.051	1,42	18,5	13	21,3	15	27	19	30	21
		64	R21.016.064	1,10	17,6	16	20,9	19	26,4	24	29,7	27
		76	R21.016.076	0,90	17,1	19	20,7	23	25,2	28	29,7	33
		89	R21.016.089	0,76	16,7	22	20,5	27	25,1	33	29,6	39
		102	R21.016.102	0,66	17,2	26	20,5	31	25,1	38	29,6	45
		305	R21.016.305	0,21	16	76	19,1	91	23,9	114	29	138

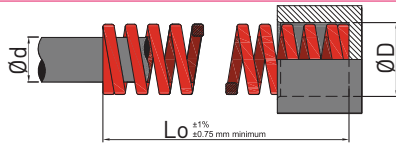

Diameters : 10 to 20mm  
Rectangular wire



Hole Ø mm	Rod Ø mm	Free length mm	Reference	RATE (daN) required to deflect 1 mm	LOAD TABLE							
					S1 Total deflection recommended for long life (20% of Lo)		S2 Total deflection recommended for average life (25% of Lo)		S3 Maximum operating deflection (30% of Lo)		Total travel to solid	
					C	Load daN	Deflect. mm	Load daN	Deflect. mm	Load daN	Deflect. mm	Load daN
10	5	25	S26.010.025	2,21	11,05	5	13,7	6,2	16,6	7,5	20,6	9,3
		32	S26.010.032	1,75	11,37	6,5	14	8	16,8	9,6	20,8	11,9
		38	S26.010.038	1,71	12,82	7,5	16,24	9,5	18,8	11	28,6	16,7
		44	S26.010.044	1,50	13,5	9	16,5	11	19,5	13	29,7	19,8
		51	S26.010.051	1,28	12,8	10	16,64	13	19,2	15	28,2	22
		64	S26.010.064	1,07	13,91	13	17,12	16	20,3	19	31,0	29
		76	S26.010.076	0,75	11,25	15	14,25	19	17,3	23	24,8	33
305	S26.010.305	0,21	12,81	61	15,96	76	19,1	91	28,1	134		
12,5	6,3	25	S26.012.025	4,21	21,05	5	26,10	6,2	31,6	7,5	46,7	11,1
		32	S26.012.032	3,32	21,58	6,5	26,56	8	31,9	9,6	47,5	14,3
		38	S26.012.038	2,93	21,97	7,5	27,83	9,5	32,2	11	51,6	17,6
		44	S26.012.044	2,46	22,14	9	27,06	11	32,0	13	51,7	21
		51	S26.012.051	1,96	19,60	10	25,48	13	29,4	15	47,0	24
		64	S26.012.064	1,50	19,50	13	24,00	16	28,5	19	43,5	29
		76	S26.012.076	1,32	19,80	15	25,08	19	30,4	23	48,8	37
89	S26.012.089	1,14	20,52	18	25,08	22	30,8	27	47,9	42		
305	S26.012.305	0,28	17,08	61	21,28	76	25,5	91	40,6	145		
16	8	25	S26.016.025	7,57	37,85	5	46,93	6,2	56,8	7,5	71,2	9,4
		32	S26.016.032	5,28	34,32	6,5	42,24	8	50,7	9,6	67,1	12,7
		38	S26.016.038	4,85	36,37	7,5	46,07	9,5	53,4	11	74,2	15,3
		44	S26.016.044	4,28	38,52	9	47,08	11	55,6	13	81,7	19,1
		51	S26.016.051	3,71	37,10	10	48,23	13	55,7	15	77,9	21
		64	S26.016.064	3,03	39,39	13	48,48	16	57,6	19	81,8	27
		76	S26.016.076	2,57	38,55	15	48,83	19	59,1	23	87,4	34
89	S26.016.089	2,17	39,06	18	47,74	22	58,6	27	86,8	40		
102	S26.016.102	1,93	38,60	20	50,18	26	59,8	31	88,8	46		
305	S26.016.305	0,71	43,31	61	53,96	76	64,6	91	98,0	138		
20	10	25	S26.020.025	23,1	116	5	143	6,2	173	7,5	194	8,4
		32	S26.020.032	17,4	113	6,5	139	8	167	9,6	183	10,5
		38	S26.020.038	13,9	106	7,5	132	9,5	153	11	174	12,5
		44	S26.020.044	11,4	103	9	127	11	148	13	165	14,5
		51	S26.020.051	9,8	101	10	127	13	147	15	162	16,5
		64	S26.020.064	7,7	100	13	128	16	146	19	162	21
		76	S26.020.076	6,3	97	15	120	19	145	23	162	26
		89	S26.020.089	5,4	97	18	120	22	145	27	162	30
		102	S26.020.102	4,7	94	20	120	26	145	31	162	35
		115	S26.020.115	4,1	94	23	119	29	144	35	162	40
		127	S26.020.127	3,7	93	25	118	32	141	38	162	44
		140	S26.020.140	3,4	95	28	119	35	143	42	167	49
		152	S26.020.152	3,08	92	30	117	38	141	46	162	53
305	S26.020.305	1,50	91	61	114	76	137	91	162	108		

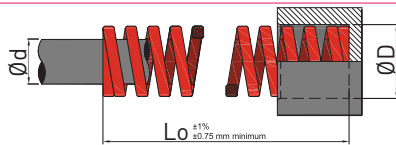

Diameters : 25 to 50mm  
Rectangular wire



Hole Ø mm	Rod Ø mm	Free length mm	Reference	RATE (daN) required to deflect 1 mm	LOAD TABLE							
					S1 Total deflection recommended for long life (20% of Lo)		S2 Total deflection recommended for average life (25% of Lo)		S3 Maximum operating deflection (30% of Lo)		Total travel to solid	
					Load daN	Deflect. mm	Load daN	Deflect. mm	Load daN	Deflect. mm	Load daN	Deflect. mm
<b>D</b>	<b>d</b>	<b>Lo</b>		<b>C</b>								
25	12,5	32	S26.025.032	27,6	179	6,5	221	8	265	9,6	290	10,5
		38	S26.025.038	22,0	165	7,5	209	9,5	242	11	286	13
		44	S26.025.044	18,4	166	9	202	11	239	13	285	15,5
		51	S26.025.051	15,7	157	10	204	13	236	15	283	18
		64	S26.025.064	12,2	159	13	195	16	232	19	275	22,5
		76	S26.025.076	10,0	150	15	190	19	230	23	275	27,5
		89	S26.025.089	8,4	151	18	185	22	227	27	275	32,5
		102	S26.025.102	7,4	148	20	192	26	229	31	275	37,5
		115	S26.025.115	6,5	150	23	189	29	228	35	275	42,7
		127	S26.025.127	5,8	145	25	186	32	220	38	273	47
		140	S26.025.140	5,2	146	28	182	35	218	42	270	52
		152	S26.025.152	4,8	144	30	182	38	221	46	273	57,5
		178	S26.025.178	4,1	148	36	180	44	217	53	273	68
		203	S26.025.203	3,59	144	40	183	51	219	61	273	77
305	S26.025.305	2,42	148	61	184	76	220	91	273	115		
32	16	38	S26.032.038	37,6	282	7,5	357	9,5	414	11	451	12
		44	S26.032.044	31,0	279	9	341	11	403	13	440	14
		51	S26.032.051	26,3	263	10	342	13	394	15	435	16,5
		64	S26.032.064	20,5	267	13	328	16	389	19	435	21,5
		76	S26.032.076	16,6	249	15	315	19	382	23	430	26
		89	S26.032.089	13,9	250	18	306	22	375	27	425	30,5
		102	S26.032.102	12,1	242	20	315	26	375	31	425	35,5
		115	S26.032.115	10,6	244	23	307	29	371	35	425	40,5
		127	S26.032.127	9,6	240	25	307	32	365	38	425	45
		140	S26.032.140	8,6	241	28	301	35	361	42	430	50
		152	S26.032.152	7,9	237	30	300	38	363	46	425	54
		178	S26.032.178	6,7	241	36	295	44	355	53	420	63
		203	S26.032.203	5,8	232	40	296	51	354	61	420	72
		254	S26.032.254	4,6	235	51	294	64	350	76	420	92
305	S26.032.305	3,8	232	61	289	76	346	91	420	110		
40	20	51	S26.040.051	34,9	349	10	454	13	524	15	593	17
		64	S26.040.064	26,6	346	13	426	16	505	19	585	22
		76	S26.040.076	21,5	323	15	409	19	495	23	580	27
		89	S26.040.089	18,0	324	18	396	22	486	27	575	32
		102	S26.040.102	15,7	314	20	408	26	487	31	575	37
		115	S26.040.115	13,8	317	23	400	29	483	35	575	42
		127	S26.040.127	12,4	310	25	397	32	471	38	575	47
		140	S26.040.140	11,3	316	28	396	35	475	42	588	52
		152	S26.040.152	10,2	306	30	388	38	469	46	575	57,5
		178	S26.040.178	8,7	313	36	383	44	461	53	575	67
		203	S26.040.203	7,6	304	40	388	51	464	61	575	76
		254	S26.040.254	6,0	306	51	384	64	456	76	575	97
		305	S26.040.305	5,0	305	61	380	76	455	91	575	116
		50	25	64	S26.050.064	42,3	550	13	677	16	804	19
76	S26.050.076			33,8	507	15	642	19	777	23	879	26
89	S26.050.089			28,1	506	18	618	22	759	27	860	30,5
102	S26.050.102			24,5	490	20	637	26	760	31	860	35
115	S26.050.115			21,5	495	23	624	29	753	35	860	40
127	S26.050.127			18,9	473	25	605	32	718	38	850	45
140	S26.050.140			16,9	473	28	592	35	710	42	845	50
152	S26.050.152			15,4	462	30	585	38	708	46	830	54
178	S26.050.178			13,2	475	36	581	44	700	53	830	64
203	S26.050.203			11,5	460	40	587	51	701	61	830	72,5
254	S26.050.254			9,0	459	51	576	64	684	76	825	92
305	S26.050.305			7,5	457	61	570	76	683	91	825	112

1 daN = 1.0197 kg

Note: Need for internal guide (Lo ≥ 4xØ)

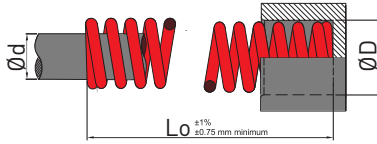

Diameters : 10 to 16mm  
Round wire



Hole Ø mm	Rod Ø mm	Free length mm	Reference	RATE (daN) required to deflect 1 mm	LOAD TABLE							
					S1 Total deflection recommended for long life (20% of Lo)		S2 Total deflection recommended for average life (25% of Lo)		S3 Maximum operating deflection (30% of Lo)		Total travel to solid	
					Load daN	Deflect. mm	Load daN	Deflect. mm	Load daN	Deflect. mm	Load daN	Deflect. mm
<b>D</b>	<b>d</b>	<b>Lo</b>	<b>C</b>	<b>C</b>	Load daN	Deflect. mm	Load daN	Deflect. mm	Load daN	Deflect. mm	Load daN	Deflect. mm
<b>10</b>	<b>5</b>	25	R26.010.025	2,13	10,5	5	13	6,2	16	7,5	19	8,9
		32	R26.010.032	1,64	10,5	6,5	13	8	15,5	9,6	19	11,7
		38	R26.010.038	1,33	10	7,5	12,5	9,5	14,5	11	18,5	14
		44	R26.010.044	1,13	10	9	12,5	11	14,5	13	18,5	17
		51	R26.010.051	0,98	10	10	12,5	13	14,5	15	18,5	19
		64	R26.010.064	0,78	10	13	12,5	16	14,5	19	18,5	25
		76	R26.010.076	0,63	9,5	15	12	19	14,5	23	18	29
		305	R26.010.305	0,15	9	61	11,5	76	13,5	91	18	120
<b>12,5</b>	<b>6,3</b>	25	R26.012.025	3,9	19,5	5	24	6,2	29	7,5	34	8,7
		32	R26.012.032	3,0	19,5	6,5	24	8	29	9,6	33	11,0
		38	R26.012.038	2,42	18	7,5	23	9,5	27	11	32	13,5
		44	R26.012.044	2,01	18	9	22	11	26	13	32	16
		51	R26.012.051	1,77	18	10	23	13	27	15	32	19
		64	R26.012.064	1,38	18	13	22	16	26	19	32	24
		76	R26.012.076	1,14	17	15	21,5	19	26	23	32	29
		89	R26.012.089	0,96	17,3	18	21,1	22	25,9	27	32	33
305	R26.012.305	0,27	16,5	61	20,5	76	24,5	91	32	120		
<b>16</b>	<b>8</b>	25	R26.016.025	8,7	44	5	54	6,2	65	7,5	76	8,7
		32	R26.016.032	6,4	42	6,5	51	8	61	9,6	70	11
		38	R26.016.038	5,2	39	7,5	49	9,5	57	11	70	13,7
		44	R26.016.044	4,2	38	9	46	11	55	13	66	15,7
		51	R26.016.051	3,64	36	10	47	13	55	15	66	18,5
		64	R26.016.064	2,84	37	13	45	16	54	19	66	23,5
		76	R26.016.076	2,33	35	15	44	19	54	23	66	29
		89	R26.016.089	1,98	36	18	44	22	53	27	66	34,5
		102	R26.016.102	1,72	34	20	45	26	53	31	66	40
		305	R26.016.305	0,54	33	61	41	76	49	91	66	122

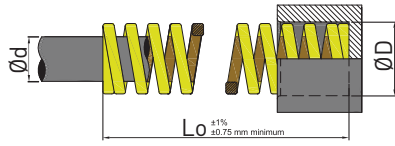

Diameters : 10 to 20mm  
Rectangular wire



Hole Ø mm	Rod Ø mm	Free length mm	Reference	RATE (daN) required to deflect 1 mm	LOAD TABLE							
					S1 Total deflection recommended for long life (17% of Lo)		S2 Total deflection recommended for average life (20% of Lo)		S3 Maximum operating deflection (25% of Lo)		Total travel to solid	
					Load daN	Deflect. mm	Load daN	Deflect. mm	Load daN	Deflect. mm	Load daN	Deflect. mm
<b>D</b>	<b>d</b>	<b>Lo</b>	<b>C</b>									
10	5	25	S36.010.025	3,27	13,7	4,2	16,4	5	20,3	6,2	29,5	8,7
		32	S36.010.032	2,50	13,8	5,5	16,3	6,5	20	8	27	10,5
		38	S36.010.038	2,12	13,8	6,5	15,2	7,5	20,1	9,5	27	13,2
		44	S36.010.044	1,77	13,3	7,5	15,9	9	19,5	11	26,5	15
		51	S36.010.051	1,53	13,3	8,7	15,3	10	19,9	13	26,5	17
		64	S36.010.064	1,22	13,4	11	15,9	13	19,5	16	26,5	21,5
		76	S36.010.076	1,01	13,1	13	15,2	15	19,2	19	26,5	26,5
		305	S36.010.305	0,25	13	52	15,3	61	19	76	26	106
12,5	6,3	25	S36.012.025	5,87	24,7	4,2	29,4	5	36,4	6,2	53	9
		32	S36.012.032	4,43	24,4	5,5	28,8	6,5	35,4	8	48	10,8
		38	S36.012.038	3,63	23,6	6,5	27,2	7,5	34,5	9,5	47	13
		44	S36.012.044	3,06	23	7,5	27,5	9	33,7	11	47	15,5
		51	S36.012.051	2,71	23,6	8,7	27,1	10	35,2	13	47	18
		64	S36.012.064	2,17	23,9	11	28,2	13	34,7	16	47	22
		76	S36.012.076	1,77	23	13	26,6	15	33,6	19	47	27
		89	S36.012.089	1,51	22,7	15	27,2	18	33	22	50	33
305	S36.012.305	0,42	21,8	52	25,6	61	31,9	76	47	112		
16	8	25	S36.016.025	12,6	53	4,2	63	5	78	6,2	113	9
		32	S36.016.032	9,3	51	5,5	60	6,5	74	8	103	10,8
		38	S36.016.038	7,5	49	6,5	56	7,5	71	9,5	98	13
		44	S36.016.044	6,3	47	7,5	57	9	69	11	96	15
		51	S36.016.051	5,5	48	8,7	55	10	72	13	96	18
		64	S36.016.064	4,3	47	11	56	13	69	16	95	22
		76	S36.016.076	3,52	46	13	53	15	67	19	94	26,5
		89	S36.016.089	3,00	45	15	54	18	66	22	94	31,5
102	S36.016.102	2,61	44	17	52	20	68	26	94	36,5		
305	S36.016.305	0,85	44	52	52	61	65	76	94	110		
20	10	25	S36.020.025	32,2	135	4,2	161	5	202	6,2	248	7,7
		32	S36.020.032	24,2	133	5,5	157	6,5	194	8	237	9,8
		38	S36.020.038	19,5	127	6,5	146	7,5	185	9,5	234	12
		44	S36.020.044	16,3	122	7,5	147	9	179	11	228	14
		51	S36.020.051	14,0	122	8,7	140	10	182	13	225	16
		64	S36.020.064	10,9	120	11	142	13	174	16	225	21
		76	S36.020.076	9,0	117	13	135	15	171	19	225	25
		89	S36.020.089	7,6	114	15	137	18	167	22	225	30
		102	S36.020.102	6,6	112	17	132	20	172	26	225	34
		115	S36.020.115	5,8	116	20	133	23	168	29	220	38
		127	S36.020.127	5,2	114	22	130	25	166	32	220	43
		140	S36.020.140	4,7	113	24	132	28	165	35	221	47
		152	S36.020.152	4,3	112	26	129	30	163	38	220	51
305	S36.020.305	2,12	110	52	129	61	161	76	220	105		

# EXTRA-HEAVY LOAD SPRINGS

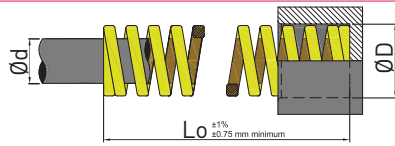

Diameters : 25 to 50mm  
Rectangular wire



Hole Ø mm	Rod Ø mm	Free length mm	Reference	RATE [daN] required to deflect 1 mm	LOAD TABLE							
					S1 Total deflection recommended for long life (17% of Lo)		S2 Total deflection recommended for average life (20% of Lo)		S3 Maximum operating deflection (25% of Lo)		Total travel to solid	
					Load daN	Deflect. mm	Load daN	Deflect. mm	Load daN	Deflect. mm	Load daN	Deflect. mm
D	d	Lo	C	C	Load daN	Deflect. mm	Load daN	Deflect. mm	Load daN	Deflect. mm	Load daN	Deflect. mm
25	12,5	32	S36.025.032	35,4	195	5,5	230	6,5	283	8	354	10
		38	S36.025.038	28,0	182	6,5	210	7,5	266	9,5	336	12
		44	S36.025.044	23,2	174	7,5	209	9	255	11	325	14
		51	S36.025.051	19,8	172	8,7	198	10	257	13	317	16
		64	S36.025.064	15,4	169	11	200	13	246	16	316	21
		76	S36.025.076	12,5	163	13	188	15	238	19	313	25
		89	S36.025.089	10,5	158	15	189	18	231	22	310	29
		102	S36.025.102	9,1	155	17	182	20	237	26	310	34
		115	S36.025.115	8,1	162	20	186	23	235	29	310	39
		127	S36.025.127	7,2	158	22	180	25	230	32	310	43
		140	S36.025.140	6,6	158	24	185	28	231	35	317	48
		152	S36.025.152	6,0	156	26	180	30	228	38	310	53
		178	S36.025.178	5,1	153	30	184	36	224	44	310	62
203	S36.025.203	4,5	153	34	180	40	230	51	310	70		
305	S36.025.305	2,96	154	52	181	61	225	76	310	108		
32	16	38	S36.032.038	48,9	318	6,5	367	7,5	465	9,5	558	11
		44	S36.032.044	40,5	304	7,5	365	9	446	11	547	13
		51	S36.032.051	34,6	301	8,7	346	10	450	13	535	15
		64	S36.032.064	26,7	294	11	347	13	427	16	535	20
		76	S36.032.076	21,6	281	13	324	15	410	19	525	24
		89	S36.032.089	18,2	273	15	328	18	400	22	525	29
		102	S36.032.102	15,6	265	17	312	20	406	26	520	33
		115	S36.032.115	13,6	272	20	313	23	394	29	500	36
		127	S36.032.127	12,2	268	22	305	25	390	32	500	41
		140	S36.032.140	11,2	269	24	314	28	392	35	526	47
		152	S36.032.152	10,1	263	26	303	30	384	38	500	50
		178	S36.032.178	8,6	258	30	310	36	378	44	500	59
		203	S36.032.203	7,5	255	34	308	40	383	51	500	68
254	S36.032.254	6,0	258	43	306	51	384	64	500	85		
305	S36.032.305	5,0	260	52	305	61	380	76	500	103		
40	20	51	S36.040.051	56,0	487	8,7	560	10	714	13	840	15
		64	S36.040.064	42,2	464	11	549	13	675	16	820	19
		76	S36.040.076	34,3	446	13	525	15	652	19	815	24
		89	S36.040.089	28,2	423	15	508	18	620	22	800	28
		102	S36.040.102	24,4	415	17	488	20	634	26	800	33
		115	S36.040.115	21,4	428	20	492	23	621	29	792	37
		127	S36.040.127	19,0	418	22	475	25	608	32	780	41
		140	S36.040.140	17,1	410	24	479	28	599	35	787	46
		152	S36.040.152	15,6	406	26	468	30	593	38	780	50
		178	S36.040.178	13,2	396	30	475	36	581	44	765	58
		203	S36.040.203	11,4	388	34	456	40	581	51	765	67
		254	S36.040.254	9,1	391	43	464	51	582	64	765	85
		305	S36.040.305	7,5	390	52	458	61	570	76	760	102
50	25	64	S36.050.064	72,4	796	11	941	13	1158	16	1376	19
		76	S36.050.076	57,3	745	13	860	15	1089	19	1318	23
		89	S36.050.089	47,4	711	15	853	18	1043	22	1280	27
		102	S36.050.102	40,4	687	17	808	20	1050	26	1252	31
		115	S36.050.115	35,3	706	20	812	23	1024	29	1235	35
		127	S36.050.127	31,2	686	22	780	25	998	32	1217	39
		140	S36.050.140	28,2	677	24	790	28	987	35	1241	44
		152	S36.050.152	25,5	663	26	765	30	969	38	1200	47
		178	S36.050.178	21,5	645	30	774	36	946	44	1200	56
		203	S36.050.203	18,6	632	34	744	40	949	51	1190	64
		254	S36.050.254	14,6	628	43	745	51	934	64	1170	80
		305	S36.050.305	12,1	629	52	738	61	920	76	1170	97

1 daN = 1.0197 kg

Note: Need for internal guide (Lo ≥ 4xD)



### Preloaded springs offer key benefits

Each spring is individually attached and pre-loaded to the desired length. When assembling the tool, there is no need to compress all of the springs. In the resting position, the springs are not preloaded by the retainer. This saves time and improves safety during assembly and maintenance operations.

D1	D2	D3	D4	L1	L2	L3	Reference
37	20	16,5	10	48	3	4	FH2
49	25	21,5	13,5	48	4	3	FH3
49	25	21,5	13,5	73	4	3	FH4



### Assembly examples

- A** Preloaded spring with FH<sub>x</sub> retainer and A17.xxx.xxx shoulder screw
- B** Preloaded spring with S65.010.xxx washer and A15.xxx.xxx locking grub screw
- C** Travel is restricted using an A15.xxx.xxx locking grub screw

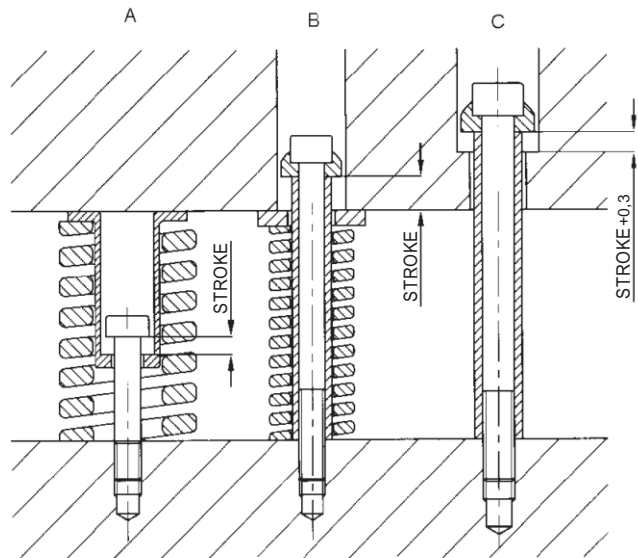
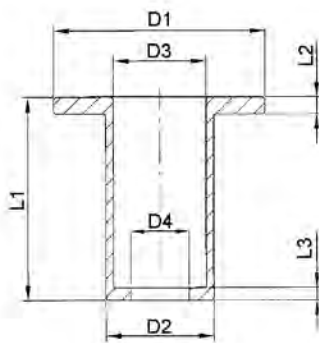



### Ordering example:

Solid 80 rod, Shore A, ØD=16 L=300

Please state: **S68.016.300**

Elastomer rods are available in two hardness qualities.

80 Shore A  
Maximum travel: 35%  
Compaction under compression: 5-7%

90 Shore A  
Maximum travel: 30%  
Compaction under compression 6-8%

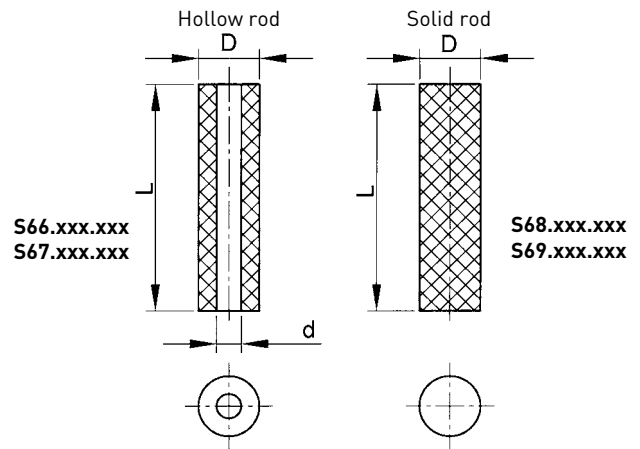

D	d	L	80 Shore A Reference Hollow rod	90 Shore A Reference Hollow rod
16	6,5	300	S66.016.300	S67.016.300
20	8,5	300	S66.020.300	S67.020.300
25	10,5	300	S66.025.300	S67.025.300
32	13,5	300	S66.032.300	S67.032.300
40	13,5	300	S66.040.300	S67.040.300
50	17	400	S66.050.400	S67.050.400
63	17	400	S66.063.400	S67.063.400
80	21	400	S66.080.400	S67.080.400
100	21	300	S66.100.300	S67.100.300
125	27	300	S66.125.300	S67.125.300

D	L	80 Shore A Reference Solid rod	90 Shore A Reference Solid rod
16	300	S68.016.300	S69.016.300
20	300	S68.020.300	S69.020.300
25	300	S68.025.300	S69.025.300
32	300	S68.032.300	S69.032.300
40	300	S68.040.300	S69.040.300
50	400	S68.050.400	S69.050.400
63	400	S68.063.400	S69.063.400
80	400	S68.080.400	S69.080.400
100	300	S68.100.300	S69.100.300
125	300	S68.125.300	S69.125.300

Processing	80 Shore A	90 Shore A
Sawing	+	+
Cutting	++	++
Drilling	0	+
Reaming	++	++
Lathe turning	0	+
Milling	+	++
Grinding	+	+
Tapping	-	-
++ Very good + Good 0 Satisfactory - Subject to reserv.		
When manufacturing special springs, the length L must not be exceeded		

Resistance	80 Shore A	90 Shore A
Lubricant	+	+
Grease	+	+
Alcohol	+	+
Thinner	+	+
Water	-	-
Ozone	+	+
Lye	-	-
Acids	-	-
+ Good - Subject to reservations		

To be mounted with guide shaft S60 or with shoulder screws A17



**Ordering example:**  
Spring  $\varnothing$  D1=16 Lo=12

Please state  
S50.016.012

### Elastomer springs

Hardness: 70 Shore A  
Max. compression: 40% of Lo  
Max. permissible temperature: 80°C  
D2: Footprint diameter when compressed to 40% of Lo

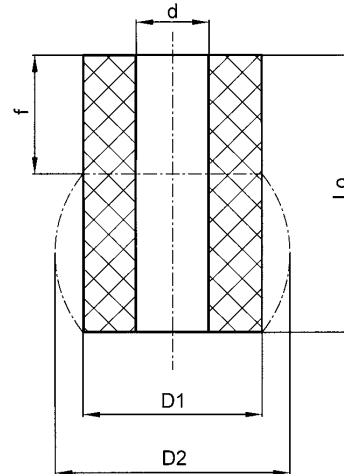

D1	d	D2 fmax	Lo	Reference
16	6,5	23	12	S50.016.012
16	6,5	23	16	S50.016.016
16	6,5	23	20	S50.016.020
16	6,5	23	25	S50.016.025
20	8,5	28	16	S50.020.016
20	8,5	28	20	S50.020.020
20	8,5	28	25	S50.020.025
20	8,5	28	32	S50.020.032
25	10,5	35	20	S50.025.020
25	10,5	35	25	S50.025.025
25	10,5	35	32	S50.025.032
25	10,5	35	40	S50.025.040
32	13,5	45	32	S50.032.032
32	13,5	45	40	S50.032.040
32	13,5	45	50	S50.032.050
32	13,5	45	63	S50.032.063
40	13,5	56	32	S50.040.032
40	13,5	56	40	S50.040.040
40	13,5	56	50	S50.040.050
40	13,5	56	63	S50.040.063
40	13,5	56	80	S50.040.080
50	17	70	32	S50.050.032
50	17	70	40	S50.050.040
50	17	70	50	S50.050.050
50	17	70	63	S50.050.063
50	17	70	80	S50.050.080
50	17	70	100	S50.050.100

D1	d	D2 fmax	Lo	Reference
63	17	89	32	S50.063.032
63	17	89	40	S50.063.040
63	17	89	50	S50.063.050
63	17	89	63	S50.063.063
63	17	89	80	S50.063.080
63	17	89	100	S50.063.100
63	17	89	125	S50.063.125
80	21	112	32	S50.080.032
80	21	112	40	S50.080.040
80	21	112	50	S50.080.050
80	21	112	63	S50.080.063
80	21	112	80	S50.080.080
80	21	112	100	S50.080.100
80	21	112	125	S50.080.125
100	21	140	32	S50.100.032
100	21	140	40	S50.100.040
100	21	140	50	S50.100.050
100	21	140	63	S50.100.063
100	21	140	80	S50.100.080
100	21	140	100	S50.100.100
100	21	140	125	S50.100.125
125	27	175	32	S50.125.032
125	27	175	40	S50.125.040
125	27	175	50	S50.125.050
125	27	175	63	S50.125.063
125	27	175	100	S50.125.100
125	27	175	125	S50.125.125
125	27	175	160	S50.125.160

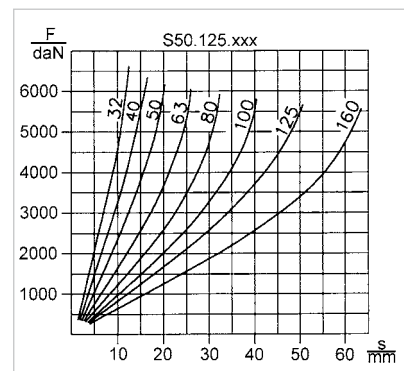
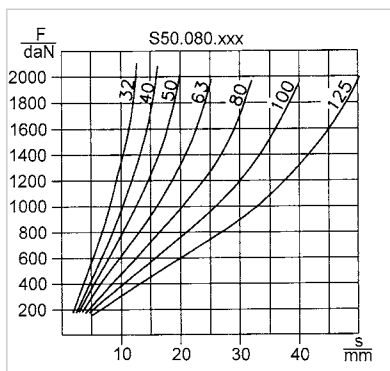
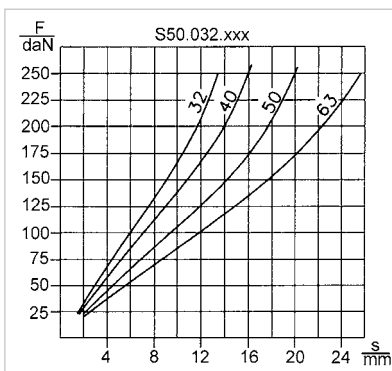
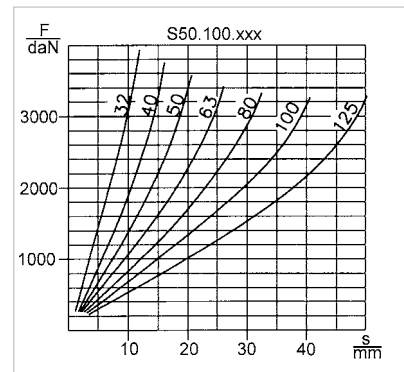
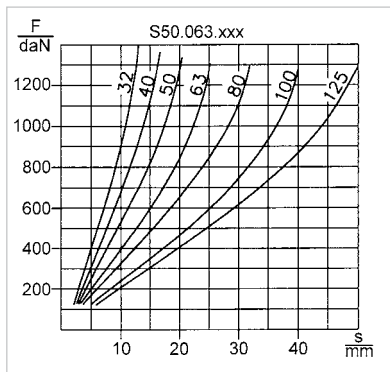
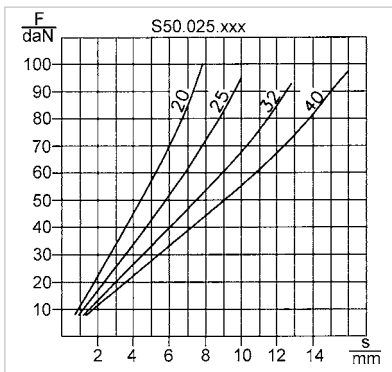
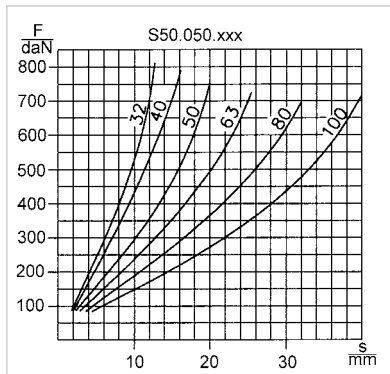
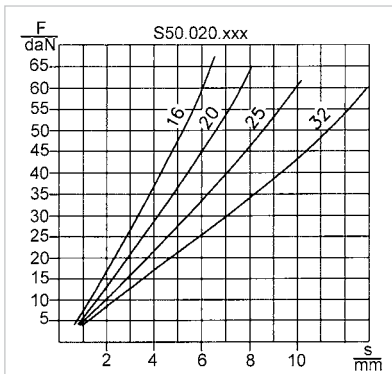
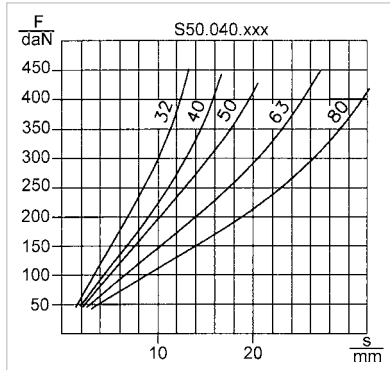
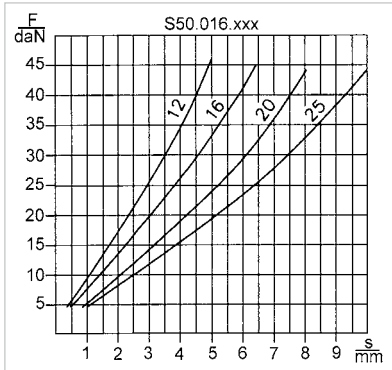

To be mounted with guide shaft S60 or with shoulder screws A17



**Ordering example**  
Spring  $\varnothing$  D1=16 Lo=12

Please state  
S55.016.012

### Elastomer springs

Hardness: 90 Shore A  
Max. compression: 30% of Lo  
Max. permissible temperature: 80°C  
D2: Footprint diameter when compressed to 30% of Lo

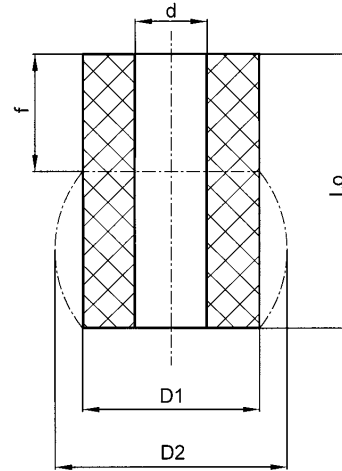

D1	d	D2 fmax	Lo	Reference
16	6,5	20	12	S55.016.012
16	6,5	20	16	S55.016.016
16	6,5	20	20	S55.016.020
16	6,5	20	25	S55.016.025
20	8,5	25	16	S55.020.016
20	8,5	25	20	S55.020.020
20	8,5	25	25	S55.020.025
20	8,5	25	32	S55.020.032
25	10,5	30	20	S55.025.020
25	10,5	30	25	S55.025.025
25	10,5	30	32	S55.025.032
25	10,5	30	40	S55.025.040
32	13,5	39	32	S55.032.032
32	13,5	39	40	S55.032.040
32	13,5	39	50	S55.032.050
32	13,5	39	63	S55.032.063
40	13,5	48	32	S55.040.032
40	13,5	48	40	S55.040.040
40	13,5	48	50	S55.040.050
40	13,5	48	63	S55.040.063
40	13,5	48	80	S55.040.080
50	17	60	32	S55.050.032
50	17	60	40	S55.050.040
50	17	60	50	S55.050.050
50	17	60	63	S55.050.063
50	17	60	80	S55.050.080
50	17	60	100	S55.050.100

D1	d	D2 fmax	Lo	Reference
63	17	76	32	S55.063.032
63	17	76	40	S55.063.040
63	17	76	50	S55.063.050
63	17	76	63	S55.063.063
63	17	76	80	S55.063.080
63	17	76	100	S55.063.100
63	17	76	125	S55.063.125
80	21	96	32	S55.080.032
80	21	96	40	S55.080.040
80	21	96	50	S55.080.050
80	21	96	63	S55.080.063
80	21	96	80	S55.080.080
80	21	96	100	S55.080.100
80	21	96	125	S55.080.125
100	21	120	32	S55.100.032
100	21	120	40	S55.100.040
100	21	120	50	S55.100.050
100	21	120	63	S55.100.063
100	21	120	80	S55.100.080
100	21	120	100	S55.100.100
100	21	120	125	S55.100.125
125	27	150	32	S55.125.032
125	27	150	40	S55.125.040
125	27	150	50	S55.125.050
125	27	150	63	S55.125.063
125	27	150	80	S55.125.080
125	27	150	100	S55.125.100
125	27	150	125	S55.125.125
125	27	150	160	S55.125.160

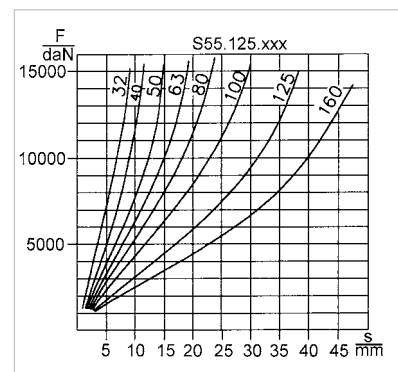
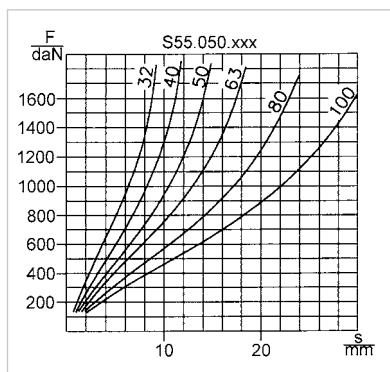
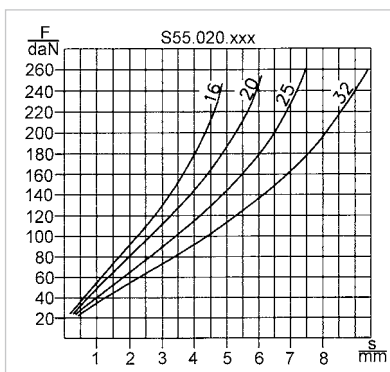
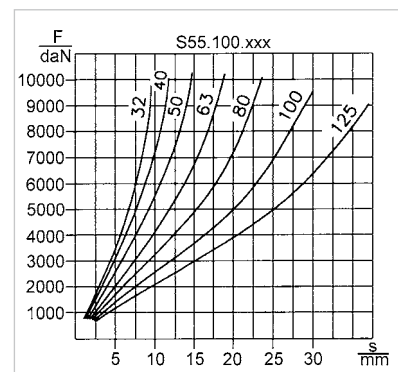
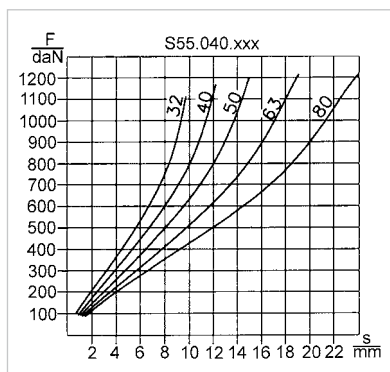
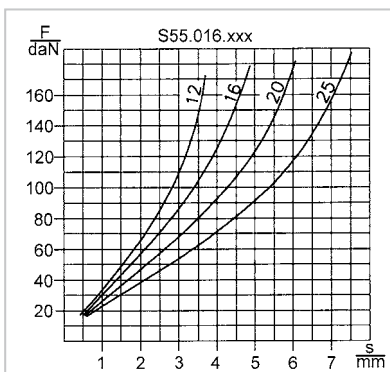
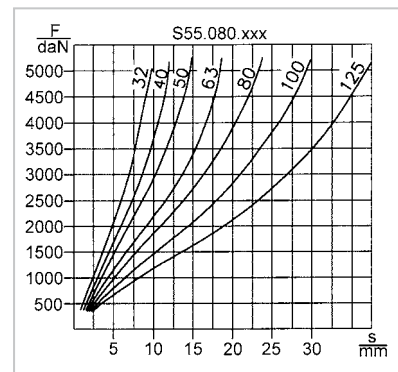
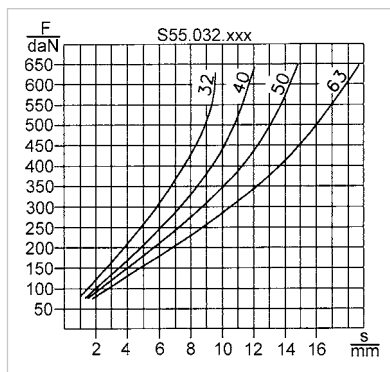
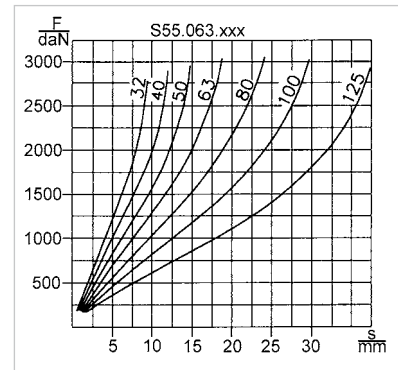
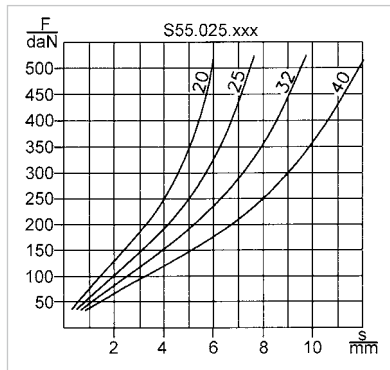





### Ordering example

Ø 6 mm guide shaft  
Length: 20 mm

Please state : **S60.006.020**

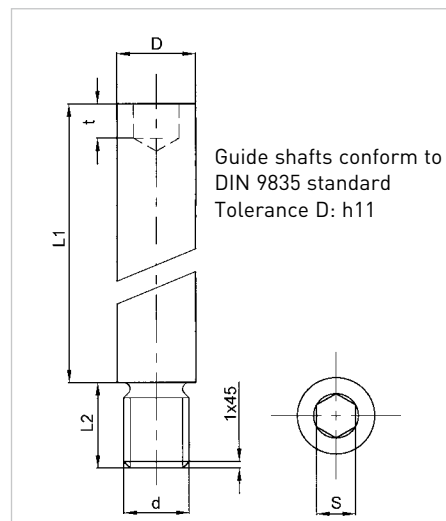
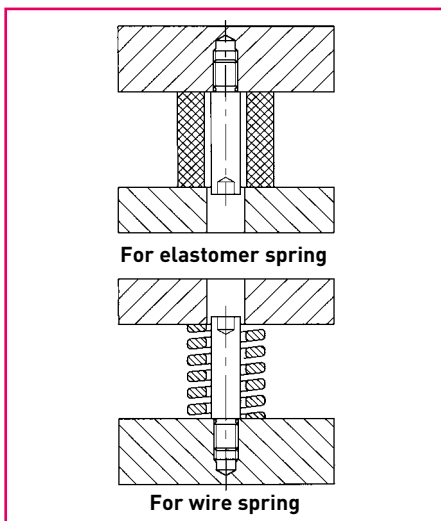

D	6	8	10	13	16	20	25	
d	M4	M6	M8	M10	M12	M16	M20	
L2	6	9	15	15	18	25	30	
s	3	4	5	6	8	10	14	
t	2,5	3	4	5	6	8	10	
L1	20	S60.006.020	S60.008.020	S60.010.020				
	25	S60.006.025	S60.008.025	S60.010.025				
	32	S60.006.032	S60.008.032	S60.010.032	S60.013.032	S60.016.032	S60.020.032	S60.025.032
	40		S60.008.040	S60.010.040	S60.013.040	S60.016.040	S60.020.040	S60.025.040
	50		S60.008.050	S60.010.050	S60.013.050	S60.016.050	S60.020.050	S60.025.050
	63			S60.010.063	S60.013.063	S60.016.063	S60.020.063	S60.025.063
	80				S60.013.080	S60.016.080	S60.020.080	S60.025.080
	95				S60.013.095	S60.016.095	S60.020.095	S60.025.095
	118					S60.016.118	S60.020.118	S60.025.118
	140					S60.016.140	S60.020.140	S60.025.140
	180							S60.025.180

Conform to : DIN 9835  
Material : Brass

### Ordering example

Ø20 washer

Please state: **S65.010.020**

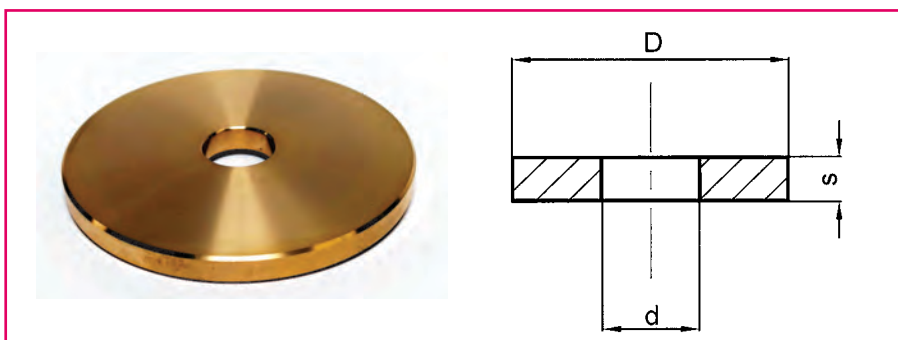

D	20	25	30	40	50	60	80	100	120	150
d	6,5	8,5	10,5	13,5	13,5	16,5	16,5	20,5	20,5	26
9	4	4	5	5	5	6	6	8	8	8
Reference	S65.010.020	S65.010.025	S65.010.030	S65.010.040	S65.010.050	S65.010.060	S65.010.080	S65.010.100	S65.010.120	S65.010.150

# ASSEMBLY INSTRUCTIONS

## Preloaded springs offer key benefits

Each spring is individually attached and pre-loaded to the desired length.  
When assembling the tool, there is no need to compress all of the springs.  
In the resting position, the springs are not preloaded by the retainer.  
This saves time and improves safety during assembly and maintenance operations.

## Assembly examples

- A** Preloaded spring with S65.xxx.xxx washer and A15.xxx.xxx locking grub screw
- B** Restriction of travel via one A15.xxx.xxx locking grub screw

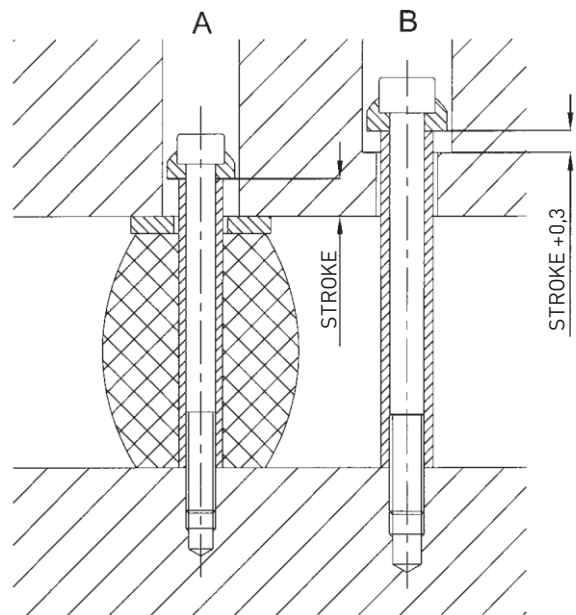

## Footprint

Elastomer springs are incompressible. Their deformation under load causes them to swell. This means that the swelling percentage is equal to the compression percentage. Therefore, it is essential to monitor the swelling curve in order to determine and define the locations and safety zones.

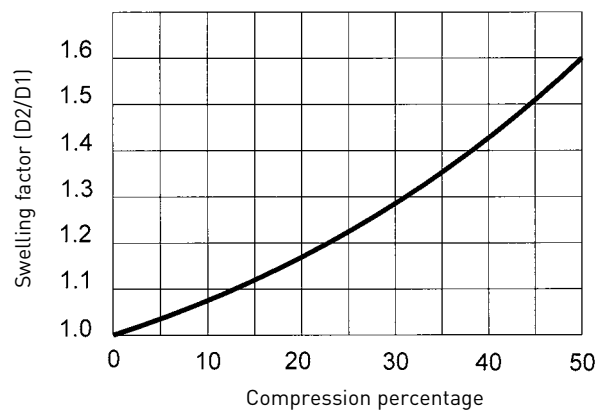



# NOTES

A large rectangular area with a thin black border, containing 20 horizontal dotted lines for writing notes.



**AMDL**  
**[www.amdl-eu.com](http://www.amdl-eu.com)**

**AMDL**

AMDL SCOP SA  
Aire d'activité du Florival  
9 rue de l'Oberwald  
FR-68500 ISSENHEIM  
Tél : +33 (0)3 89 74 24 24  
[contact@amdl-eu.com](mailto:contact@amdl-eu.com)

