

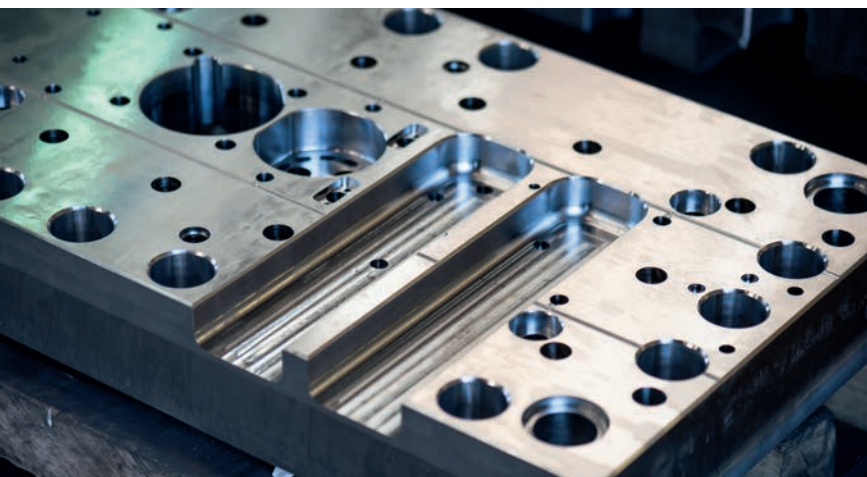

Standard components

**Precise large dimensions
machining services**



AMDL[®]
Atelier Mécanique De La Lauch

SUMMARY



Die sets

Die sets 3

Custom machining / machine capacities 25

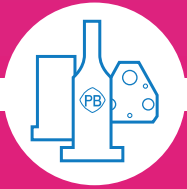

Punches and dies

Punches
Dies
Retainers
Accessories

Punches30

Dies56

Punch retainers 69

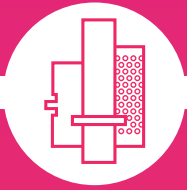

Guiding elements

Pillar
Bushes
Ball cages
Accessories

MDL Blueline range to DIN standard92

MDL range to ISO standard111

MDL Porter Besson range to AFNOR / CNOMO standard 145

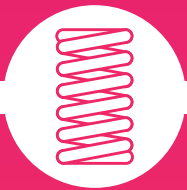

Springs

Compressions springs
Gas springs
Elastomer springs
Accessories

Compressions springs176

Elastomer springs192

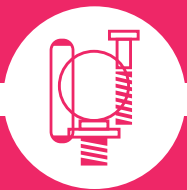

Accessories

Screws 202

Lifting211

Others 215

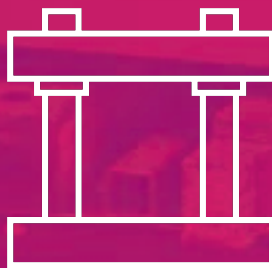
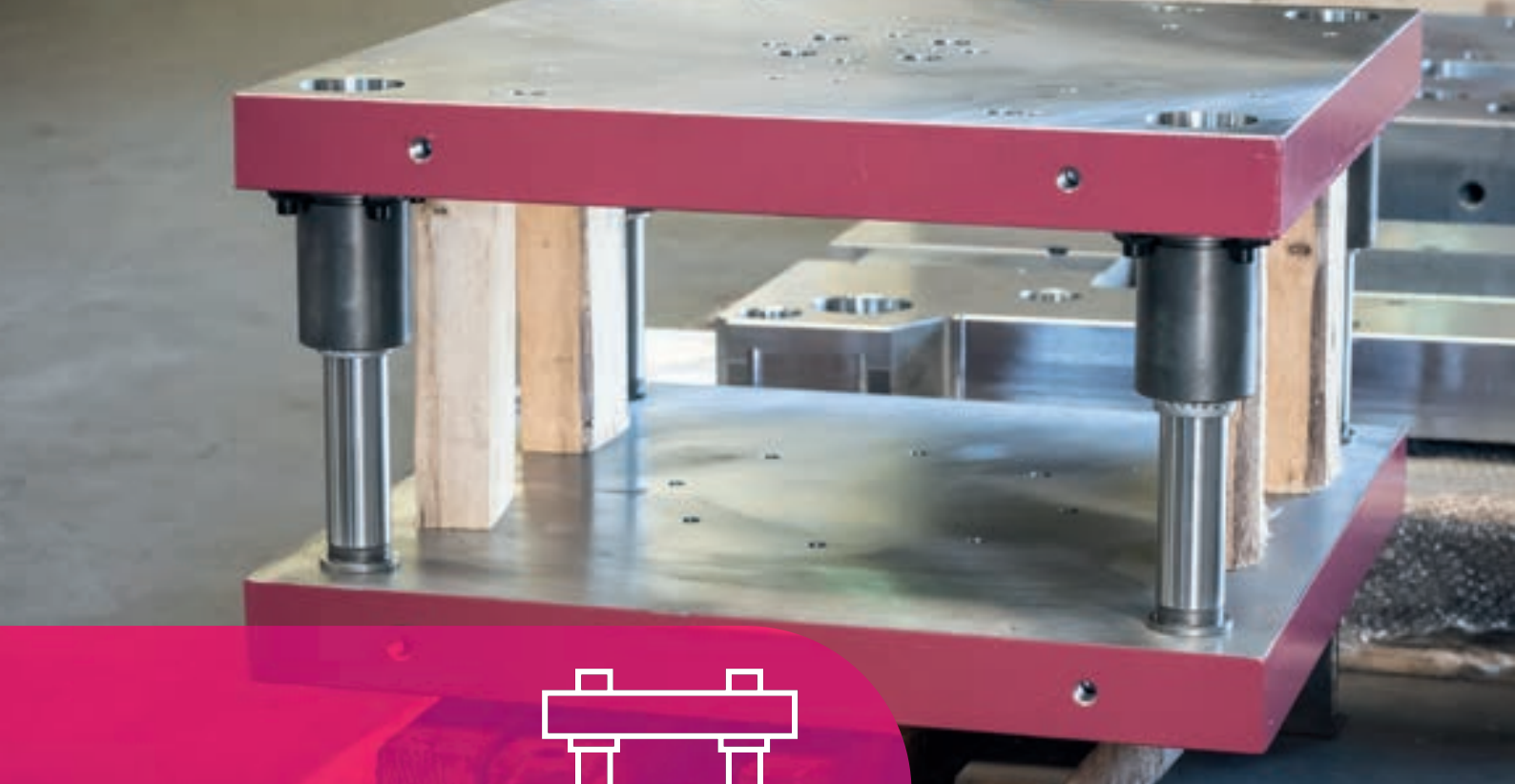

Die sets



■ Standard die sets with centre pillars D61/D71	6
■ Standard die sets with rear pillars D72	7
■ Standard die sets with diagonal pillars D63/D73	8
■ Rectangular die sets with centre pillars D81/D91	9 - 10
■ Rectangular die sets with rear pillars D92	11 - 12
■ Rectangular die sets with diagonal pillars D83/D93	13 - 14
■ Rectangular die sets with four pillars D84/D94	15 - 16
■ Rectangular die sets with central pillars and ball bearing guide bushes D86/D96	17 - 18
■ Rectangular die sets with rear pillars and ball bearing guides D97	19 - 20
■ Rectangular die sets with diagonal pillars and ball bearing guides D88/D98	21 - 22
■ Rectangular die sets with four pillars and ball bearing guides D89/D99	23 - 24

In order to provide a better response to your urgent ordering requirements, we can offer you three new die set solutions:

- Standard die sets: 48-hours delivery ex works
(See pages 3 to 5).
- Rectangular die sets: 72-hours delivery ex works
(See pages 6 to 21).
- Made-to-measure die sets: according to your plans and specifications
- Special die sets: according to individual design requirements

By matching bushes and pillars, we can offer you three adjustment categories:

Category I : For tooling processing of very thin sheet metal.
For very fine clearance between punch and die sections.
Where clearance per side is less than 0.02 mm.

Category II : For tooling processing of sheet metal more than 0.4 mm thick
For clearance between punch and die sections
from 0.02 to 0.06 mm per side.
For most applications.

Category III : For clearance between punch and die sections
of 0.08 mm per side.
For automotive, forming dies.

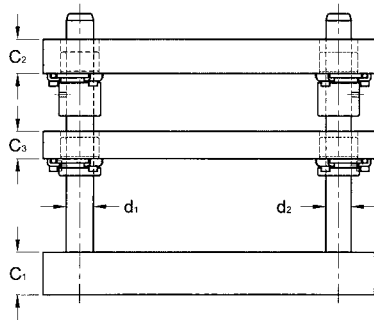

Standard die set with stripper plate Type D61.xxx.xxx

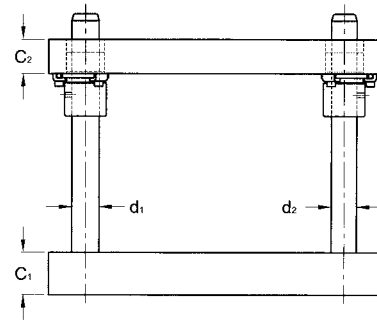

Standard die set
Type D71.xxx.xxx

The plates are torch-cut and stress relieved.
The guide elements can be chosen from our catalogue:

- Straight pillars P10.xxx.xxx
- Demountable pillars P2x.xxx.xxx
- Steel bushes B1x.xxx.xxx
- Bronze-plated bushes B2x.xxx.xxx

Delivery: 48 hours ex works

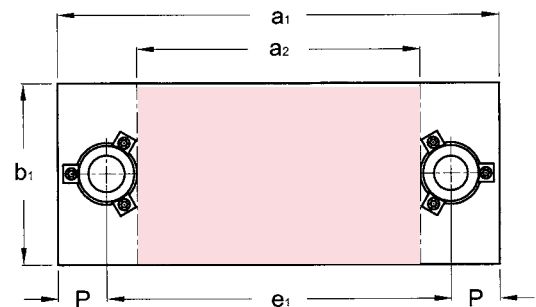

Examples

Die set with stripper plate :

D61.012.010

Identical die set without stripper plate :

D71.012.010

Ext. dimensions			C ₁ ±1	C ₂ ±1	C ₃ ±1	d ₁ /L	d ₂ /L	e ₁	P	Reference x = 6 : with C3 x = 7 : without C3
a ₂	b ₁	a ₁								
Work space										
100	80	225	32	25	25	25/160	24/160	147	39	Dx1.010.008
125		250						172		Dx1.012.008
160		285						207		Dx1.016.008
200		325						247		Dx1.020.008
100	100	225	40	32	28	32/180	30/180	147	43	Dx1.010.010
125		250						172		Dx1.012.010
160		285						207		Dx1.016.010
250		390						304		Dx1.025.010
125	125	265	50	40	32	32/200	30/200	179	52	Dx1.012.012
160		300						214		Dx1.016.012
200		340						254		Dx1.020.012
315		455						369		Dx1.031.012
160	160	300	50	40	32	32/200	30/200	214	52	Dx1.016.016
200		340						254		Dx1.020.016
250		390						304		Dx1.025.016
315		455						369		Dx1.031.016
200	200	367	50	40	32	40/220	38/220	263	52	Dx1.020.020
315		482						378		Dx1.031.020
315		482						378		Dx1.031.025

L : Pin Length recommendations

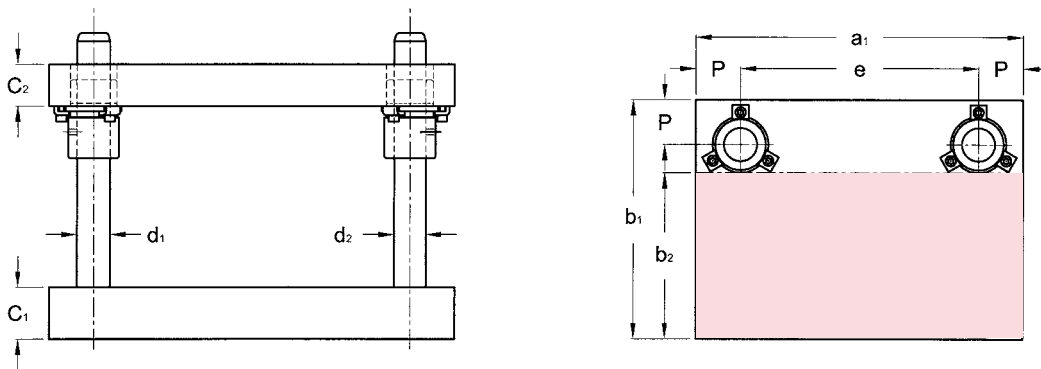

The plates are torch-cut and stress relieved.
The guide elements can be chosen from our catalogue:

- Straight pillars P10.xxx.xxx
- Demountable pillars P2x.xxx.xxx
- Steel bushes B1x.xxx.xxx
- Bronze-plated bushes B2x.xxx.xxx

Delivery: 48 hours ex works

Example

Die set with rear pillars :

D72.031.010

Ext. dimensions			C ₁ ±1	C ₂ ±1	d ₁ /L	e	P	Reference
a ₁	b ₂	b ₁						
Work space								
125						69		D72.012.006
160	63	108	25	20	20/140	104	28	D72.016.006
200						144		D72.020.006
160						82		D72.016.008
200	80	143	32	25		122		D72.020.008
250						172		D72.025.008
200					25/180	122	39	D72.020.010
250	100	163				172		D72.025.010
315						237		D72.031.010
200			40	32		114		D72.020.012
250	125	195				164		D72.025.012
315					32/200	229	43	D72.031.012
250						164		D72.025.016
315	160	230	50	40		229		D72.031.016
315	200	284	56	50	40/200	211	52	D72.031.020

L : Pin Length recommendations

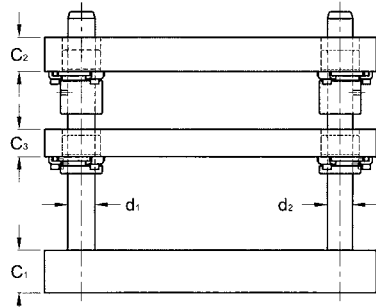

Standard die set with stripper plate
type D63.xxx.xxx

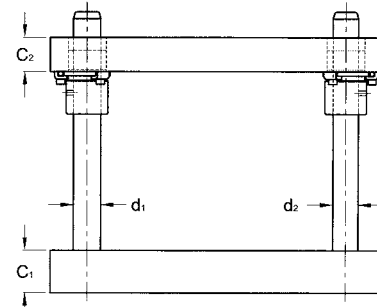

Standard die set
type D73.xxx.xxx

The plates are torch-cut and stress relieved.
The guide elements can be chosen from our catalogue :

- Straight pillars P10.xxx.xxx
- Demountable pillars P2x.xxx.xxx
- Steel bushes B1x.xxx.xxx
- Bronze-plated bushes B2x.xxx.xxx

Delivery: 48 hours ex works

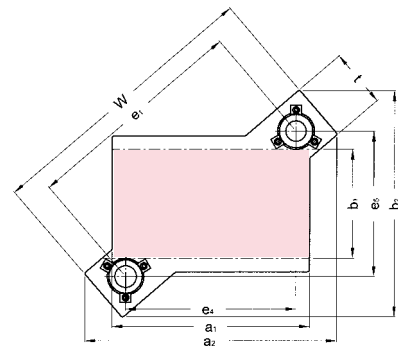

Examples

Die set with stripper plate :

D63.024.012

Identical die set without stripper plate :

D73.024.012

a ₁	b ₁	Ext. dimensions		C ₁ ±1	C ₂ ±1	C ₃ ±1	d ₁ /L	d ₂ /L	e ₁	e ₅ ≈	e ₄ ≈	t	w	Reference x = 6 : with C3 x = 7 : without C3
		a ₂	b ₂											
Work space														
165	100	235	260	32	25	25	25/180	24/180	193	147	125	78	271	Dx3.016.010
200		218							160		296		Dx3.020.010	
240		249							200		327		Dx3.024.010	
290		290							250		368		Dx3.029.010	
200	125	282	300	40	32	28	32/200	30/200	240	179	160	86	326	Dx3.020.012
240		269							200		355		Dx3.024.012	
290		308							250		394		Dx3.029.012	
355		363							315		449		Dx3.035.012	
240	160	322	335	50	40	32	40/220	38/220	293	214	200	104	379	Dx3.024.016
290		329							250		415		Dx3.029.016	
355		381							315		467		Dx3.035.016	
290	200	398	410	50	40	32	40/220	38/220	363	263	250	104	467	Dx3.029.020
355		462							315		515		Dx3.035.020	
355	250	462	460						444	313	315		548	Dx3.035.025

L : Pin Length recommendations

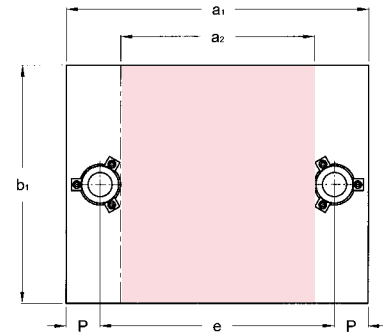
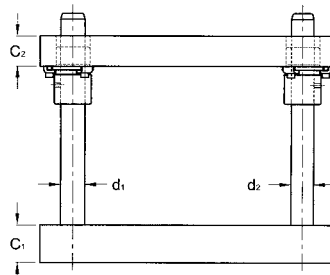
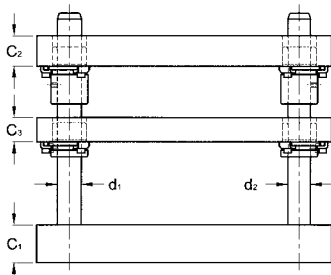

Standard assembly of bushes on underside of stripper plate.

Ext. dimensions			C ₁ ±1	C ₂ ±1	C ₃ ±1	d ₁ /L	d ₂ /L	e	P	reference x = 8 : with C3 x = 9 : without C3			
a ₁	b ₁	a ₂											
	Work space												
250	160	127	32	32	32	25/200	24/200	174	38	Dx1.125.016			
			32	40						Dx1.225.016			
			40	32						Dx1.325.016			
			40	40						Dx1.425.016			
	200		127	32						32	Dx1.125.020		
				32						40	Dx1.225.020		
				40						32	Dx1.325.020		
				40						40	Dx1.425.020		
				250						127	32	32	Dx1.125.025
32	40	Dx1.225.025											
40	32	Dx1.325.025											
40	40	Dx1.425.025											
315	200	171	32	32	32	32/200	30/200	225	45	Dx1.131.020			
			32	40						Dx1.231.020			
			40	32						Dx1.331.020			
			40	40						Dx1.431.020			
	250		171	32						32	Dx1.131.025		
				32						40	Dx1.231.025		
				40						32	Dx1.331.025		
				40						40	Dx1.431.025		
	315			171						40	40	Dx1.131.031	
										40	50	Dx1.231.031	
										50	40	Dx1.331.031	
										50	50	Dx1.431.031	
400	200	256			40	40	32	32/220	30/220	310	45	Dx1.140.020	
					40	50						Dx1.240.020	
					50	40						Dx1.340.020	
					50	50						Dx1.440.020	
	250		256		40	40						Dx1.140.025	
					40	50						Dx1.240.025	
					50	40						Dx1.340.025	
					50	50						Dx1.440.025	
	315			256	40	40						Dx1.140.031	
					40	50						Dx1.240.031	
					50	40						Dx1.340.031	
					50	50						Dx1.440.031	
	400				256	40						40	Dx1.140.040
						40						50	Dx1.240.040
						50						40	Dx1.340.040
						50						50	Dx1.440.040

L : Pin Length recommendations

The plates are torch-cut and stress relieved.
The steel or bronze-plated steel guide elements can be chosen from our "Guide Elements" catalogue.

Delivery: 72 hours ex works

Examples

Die set with stripper plate : D81.463.040
Identical die set without stripper plate : D91.463.040

Ext. dimensions		a ₂	C ₁ ±1	C ₂ ±1	C ₃ ±1	d ₁ /L	d ₂ /L	e	P	Reference x = 8 : with C3 x = 9 : without C3
a ₁	b ₁									
Work space										
500	250	337	40	40	32	40/220	38/220	400	50	Dx1.150.025
			40	50						Dx1.250.025
			50	40						Dx1.350.025
			50	50						Dx1.450.025
	315		40	40						Dx1.150.031
			40	50						Dx1.250.031
			50	40						Dx1.350.031
			50	50						Dx1.450.031
	400		40	40						Dx1.150.040
			40	50						Dx1.250.040
			50	40						Dx1.350.040
			50	50						Dx1.450.040
500	40	40	Dx1.150.050							
	40	50	Dx1.250.050							
	50	40	Dx1.350.050							
	50	50	Dx1.450.050							
630	315	435	50	50	40	50/220	48/220	510	60	Dx1.163.031
			50	58						Dx1.263.031
			58	50						Dx1.363.031
			58	58						Dx1.463.031
	400		50	50						Dx1.163.040
			50	58						Dx1.263.040
			58	50						Dx1.363.040
			58	58						Dx1.463.040
	500		50	50						Dx1.163.050
			50	58						Dx1.263.050
			58	50						Dx1.363.050
			58	58						Dx1.463.050
630	50	50	Dx1.163.063							
	50	58	Dx1.263.063							
	58	50	Dx1.363.063							
	58	58	Dx1.463.063							
710	400	515	58	58	40	50/250	48/250	590	60	Dx1.171.040
			58	63						Dx1.271.040
			63	58						Dx1.371.040
			63	63						Dx1.471.040
	500		58	58						Dx1.171.050
			58	63						Dx1.271.050
			63	58						Dx1.371.050
			63	63						Dx1.471.050
	630		58	58						Dx1.171.063
			58	63						Dx1.271.063
			63	58						Dx1.371.063
			63	63						Dx1.471.063

L : Pin Length recommendations

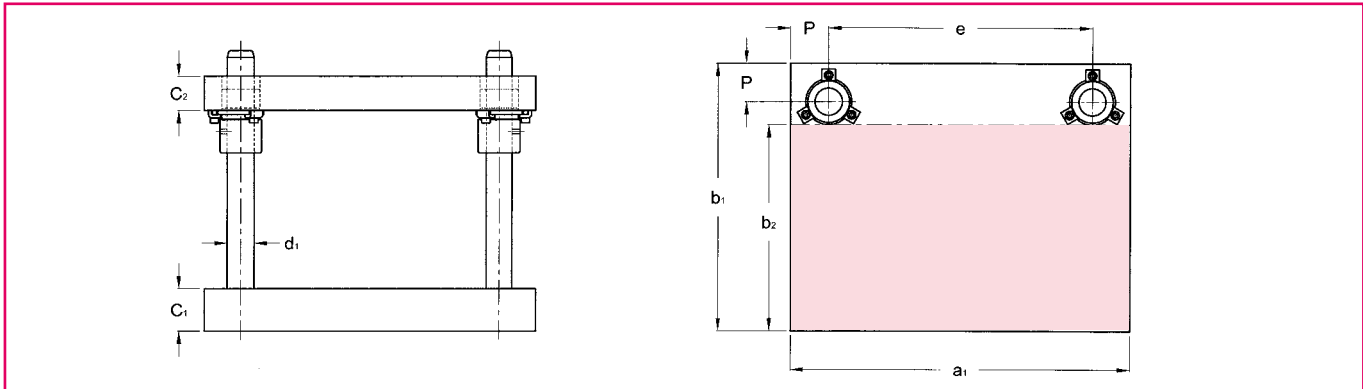

Ext. dimensions			C ₁ ±1	C ₂ ±1	d ₁ /L	e	P	Reference			
a ₁	b ₂	b ₁									
Work space											
250	98	160	32	32	25/200	174	38	D92.125.016			
			32	40				D92.225.016			
			40	32				D92.325.016			
			40	40				D92.425.016			
	138	200	32	32				D92.125.020			
			32	40				D92.225.020			
			40	32				D92.325.020			
			40	40				D92.425.020			
	188	250	32	32				D92.125.025			
32			40	D92.225.025							
40			32	D92.325.025							
40			40	D92.425.025							
315	128	200	32	32	32/200	225	45	D92.131.020			
			32	40				D92.231.020			
			40	32				D92.331.020			
			40	40				D92.431.020			
	178	250	32	32				D92.131.025			
			32	40				D92.231.025			
			40	32				D92.331.025			
			40	40				D92.431.025			
	243	315	40	40				D92.131.031			
			40	50				D92.231.031			
			50	40				D92.331.031			
			50	50				D92.431.031			
400	128	200	40	40	32/220	310	45	D92.140.020			
			40	50				D92.240.020			
			50	40				D92.340.020			
			50	50				D92.440.020			
	178	250	40	40				D92.140.025			
			40	50				D92.240.025			
			50	40				D92.340.025			
			50	50				D92.440.025			
	243	315	40	40				D92.140.031			
			40	50				D92.240.031			
			50	40				D92.340.031			
			50	50				D92.440.031			
	318	400	40	40				40/220	300	50	D92.140.040
			40	50							D92.240.040
			50	40							D92.340.040
			50	50							D92.440.040

L : Pin Length recommendations

The plates are torch-cut and stress relieved.
The steel or bronze-plated steel guide elements can be chosen from our "Guide Elements" catalogue.

Delivery: 72 hours ex works

Example

Rectangular die set with rear pillars:

D92.450.050

Ext. dimensions			C ₁ ±1	C ₂ ±1	d ₁ /L	e	P	Reference
a ₁	b ₂	b ₁						
Work space								
500	168	250	40	40	40/220	400	50	D92.150.025
			40	50				D92.250.025
			50	40				D92.350.025
			50	50				D92.450.025
	233	315	40	40				D92.150.031
			40	50				D92.250.031
			50	40				D92.350.031
			50	50				D92.450.031
	318	400	40	40				D92.150.040
			40	50				D92.250.040
			50	40				D92.350.040
			50	50				D92.450.040
418	500	40	40	D92.150.050				
		40	50	D92.250.050				
		50	40	D92.350.050				
		50	50	D92.450.050				
630	217	315	50	50	50/220	510	60	D92.163.031
			50	58				D92.263.031
			58	50				D92.363.031
			58	58				D92.463.031
	302	400	50	50				D92.163.040
			50	58				D92.263.040
			58	50				D92.363.040
			58	58				D92.463.040
	402	500	50	50				D92.163.050
			50	58				D92.263.050
			58	50				D92.363.050
			58	58				D92.463.050
532	630	50	50	D92.163.063				
		50	58	D92.263.063				
		58	50	D92.363.063				
		58	58	D92.463.063				
710	302	400	58	58	50/250	590	60	D92.171.040
			58	63				D92.271.040
			63	58				D92.371.040
			63	63				D92.471.040
	402	500	58	58				D92.171.050
			58	63				D92.271.050
			63	58				D92.371.050
			63	63				D92.471.050
	532	630	58	58				D92.171.063
			58	63				D92.271.063
			63	58				D92.371.063
			63	63				D92.471.063

L : Pin Length recommendations

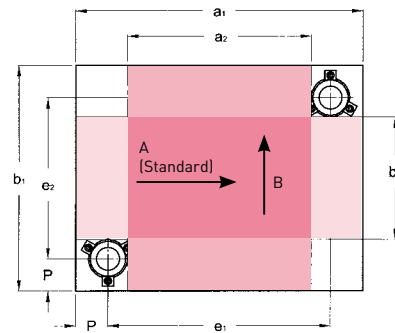
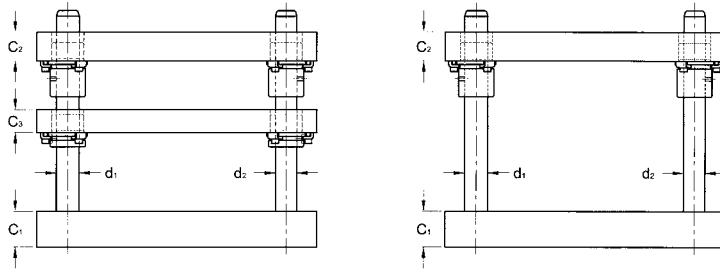

Standard assembly of bushes on underside of stripper plate.

Ext. dimensions				C ₁ ±1	C ₂ ±1	C ₃ ±1	d ₁ /L	d ₂ /L	e ₁	e ₂	P	Reference x = 8 : with C3 x = 9 : without C3	
Work space, direction A		Work space, direction B											
a ₁	b ₂	b ₁	a ₂										
250	37	160	127	32	32	32	25/200	24/200	174	84	38	Dx3.125.016	
				32	40							Dx3.225.016	
				40	32							Dx3.325.016	
				40	40							Dx3.425.016	
	77	200		127	32							32	Dx3.125.020
					32							40	Dx3.225.020
					40							32	Dx3.325.020
					40							40	Dx3.425.020
	127	250		127	32							32	Dx3.125.025
					32							40	Dx3.225.025
					40							32	Dx3.325.025
					40							40	Dx3.425.025
315	56	200	171	32	32	32	32/200	30/200	225	110	45	Dx3.131.020	
				32	40							Dx3.231.020	
				40	32							Dx3.331.020	
				40	40							Dx3.431.020	
	106	250		171	32							32	Dx3.131.025
					32							40	Dx3.231.025
					40							32	Dx3.331.025
					40							40	Dx3.431.025
	171	315		171	40							40	Dx3.131.031
					40							50	Dx3.231.031
					50							40	Dx3.331.031
					50							50	Dx3.431.031
400	56	200	256	40	40	32	32/220	30/220	310	110	45	Dx3.140.020	
				40	50							Dx3.240.020	
				50	40							Dx3.340.020	
				50	50							Dx3.440.020	
	106	250		256	40							40	Dx3.140.025
					40							50	Dx3.240.025
					50							40	Dx3.340.025
					50							50	Dx3.440.025
	171	315		256	40							40	Dx3.140.031
					40							50	Dx3.240.031
					50							40	Dx3.340.031
					50							50	Dx3.440.031
	256	400		256	40							40	Dx3.140.040
					40							50	Dx3.240.040
					50							40	Dx3.340.040
					50							50	Dx3.440.040

L : Pin Length recommendations

The plates are torch-cut and stress relieved.
The steel or bronze-plated steel guide elements can be chosen from our "Guide Elements" catalogue.

Delivery : 72 hours ex works

Examples

Die set with stripper plate : **D83.450.031**
Identical die set without stripper plate : **D93.450.031**

Ext. dimensions				C ₁ ±1	C ₂ ±1	C ₃ ±1	d ₁ /L	d ₂ /L	e ₁	e ₂	P	Références x = 8 : with C3 x = 9 : without C3		
Work space, direction A		Work space, direction B												
a ₁	b ₂	b ₁	a ₂											
500	87	250	337	40	40	32	40/220	38/220	400	150	50	Dx3.150.025		
				40	50							Dx3.250.025		
				50	40							Dx3.350.025		
				50	50							Dx3.450.025		
	152	315		40	40					40		50	215	Dx3.150.031
				40	50					Dx3.250.031				
				50	40					Dx3.350.031				
				50	50					Dx3.450.031				
	237	400		40	40					40		50	300	Dx3.150.040
				40	50					Dx3.250.040				
				50	40					Dx3.350.040				
				50	50					Dx3.450.040				
337	500	40	40	40	50	400	Dx3.150.050							
		40	50	Dx3.250.050										
		50	40	Dx3.350.050										
		50	50	Dx3.450.050										
630	120	315	435	50	50	40	50/220	48/220	510	195	60	Dx3.163.031		
				50	58							Dx3.263.031		
				58	50							Dx3.363.031		
				58	58							Dx3.463.031		
	205	400		50	50					50		58	280	Dx3.163.040
				50	58					Dx3.263.040				
				58	50					Dx3.363.040				
				58	58					Dx3.463.040				
	305	500		50	50					50		58	380	Dx3.163.050
				50	58					Dx3.263.050				
				58	50					Dx3.363.050				
				58	58					Dx3.463.050				
435	630	50	50	50	58	510	Dx3.163.063							
		50	58	Dx3.263.063										
		58	50	Dx3.363.063										
		58	58	Dx3.463.063										
710	205	400	515	58	58	40	50/250	48/250	590	280	60	Dx3.171.040		
				58	63							Dx3.271.040		
				63	58							Dx3.371.040		
				63	63							Dx3.471.040		
	305	500		58	58					58		63	380	Dx3.171.050
				58	63					Dx3.271.050				
				63	58					Dx3.371.050				
				63	63					Dx3.471.050				
	435	630		58	58					58		63	510	Dx3.171.063
				58	63					Dx3.271.063				
				63	58					Dx3.371.063				
				63	63					Dx3.471.063				

L : Pin Length recommendations

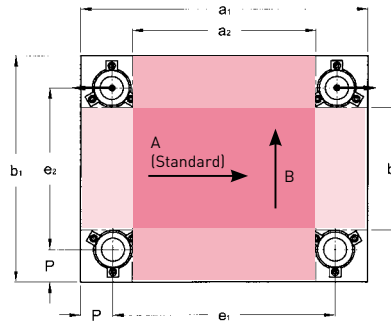
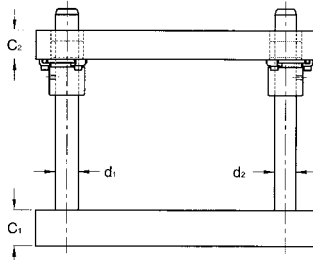
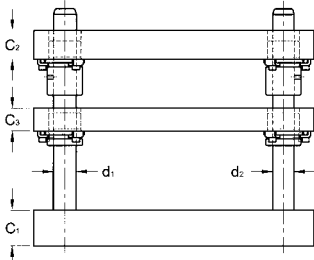

Standard assembly of bushes on underside of stripper plate.

Ext. dimensions				C ₁ ±1	C ₂ ±1	C ₃ ±1	d ₁ /L	e ₁	e ₂	P	References x = 8 : with C3 x = 9 : without C3						
Work space, direction A		Work space, direction B															
a ₁	b ₂	b ₁	a ₂														
250	37	160	127	32	32	32	25/200	174	84	38	Dx4.125.016 Dx4.225.016 Dx4.325.016 Dx4.425.016 Dx4.125.020 Dx4.225.020 Dx4.325.020 Dx4.425.020 Dx4.125.025 Dx4.225.025 Dx4.325.025 Dx4.425.025						
				32	40												
				40	32												
				40	40												
	77	200		250	32				32			32	25/200	174	124	38	Dx4.125.025 Dx4.225.025 Dx4.325.025 Dx4.425.025
					32				40								
					40				32								
					40				40								
	127	250		315	32				32			32	25/200	239	174	38	Dx4.131.025 Dx4.231.025 Dx4.331.025 Dx4.431.025
					32				40								
					40				32								
					40				40								
315	77	200	192	32	32	32	25/200	324	124	38	Dx4.131.020 Dx4.231.020 Dx4.331.020 Dx4.431.020 Dx4.131.025 Dx4.231.025 Dx4.331.025 Dx4.431.025 Dx4.131.031 Dx4.231.031 Dx4.331.031 Dx4.431.031						
				32	40												
				40	32												
				40	40												
	127	250		315	40				40			32	25/200	324	174	38	Dx4.140.020 Dx4.240.020 Dx4.340.020 Dx4.440.020
					40				50								
					50				40								
					50				50								
	192	315		400	40				40			32	25/200	310	225	45	Dx4.140.025 Dx4.240.025 Dx4.340.025 Dx4.440.025
					40				50								
					50				40								
					50				50								
400	77	200	277	40	40	32	32/220	310	124	38	Dx4.140.031 Dx4.240.031 Dx4.340.031 Dx4.440.031 Dx4.140.040 Dx4.240.040 Dx4.340.040 Dx4.440.040						
				40	50												
				50	40												
				50	50												
	127	250		400	40				40			32	32/220	310	174	45	Dx4.140.031 Dx4.240.031 Dx4.340.031 Dx4.440.031
					40				50								
					50				40								
					50				50								
	171	315		400	40				40			32	32/220	310	225	45	Dx4.140.040 Dx4.240.040 Dx4.340.040 Dx4.440.040
					40				50								
					50				40								
					50				50								
256	400	400	40	40	32	32/220	310	310	45	Dx4.140.040 Dx4.240.040 Dx4.340.040 Dx4.440.040							
			40	50													
			50	40													
			50	50													

L : Pin Length recommendations

The plates are torch-cut and stress relieved.
The steel or bronze-plated steel guide elements can be chosen from our "Guide Elements" catalogue.
The two rear pillars are offset by two mm towards the outside for foolproofing.

Delivery: 72 hours ex works

Examples

Die set with stripper plate : D84.450.031
Identical die set without stripper plate : D94.450.031

Ext. dimensions				C ₁ ±1	C ₂ ±1	C ₃ ±1	d ₁ /L	e ₁	e ₂	P	References x = 8 : with C3 x = 9 : without C3
Work space, direction A		Work space, direction B									
a ₁	b ₂	b ₁	a ₂								
500	106	250	356	40	40	32	32/220	410	160	45	Dx4.150.025
				40	50						Dx4.250.025
				50	40						Dx4.350.025
				50	50						Dx4.450.025
	171	315		40	40				Dx4.150.031		
				40	50				Dx4.250.031		
				50	40				Dx4.350.031		
				50	50				Dx4.450.031		
	256	400		40	40				Dx4.150.040		
				40	50				Dx4.250.040		
				50	40				Dx4.350.040		
				50	50				Dx4.450.040		
356	500	40	40	Dx4.150.050							
		40	50	Dx4.250.050							
		50	40	Dx4.350.050							
		50	50	Dx4.450.050							
630	152	315	467	50	50	40	40/220	530	215	50	Dx4.163.031
				50	58						Dx4.263.031
				58	50						Dx4.363.031
				58	58						Dx4.463.031
	237	400		50	50				Dx4.163.040		
				50	58				Dx4.263.040		
				58	50				Dx4.363.040		
				58	58				Dx4.463.040		
	337	500		50	50				Dx4.163.050		
				50	58				Dx4.263.050		
				58	50				Dx4.363.050		
				58	58				Dx4.463.050		
467	630	50	50	Dx4.163.063							
		50	58	Dx4.263.063							
		58	50	Dx4.363.063							
		58	58	Dx4.463.063							
710	205	400	515	58	58	40	50/250	590	280	60	Dx4.171.040
				58	63						Dx4.271.040
				63	58						Dx4.371.040
				63	63						Dx4.471.040
	305	500		58	58				Dx4.171.050		
				58	63				Dx4.271.050		
				63	58				Dx4.371.050		
				63	63				Dx4.471.050		
	435	630		58	58				Dx4.171.063		
				58	63				Dx4.271.063		
				63	58				Dx4.371.063		
				63	63				Dx4.471.063		

L : Pin Length recommendations

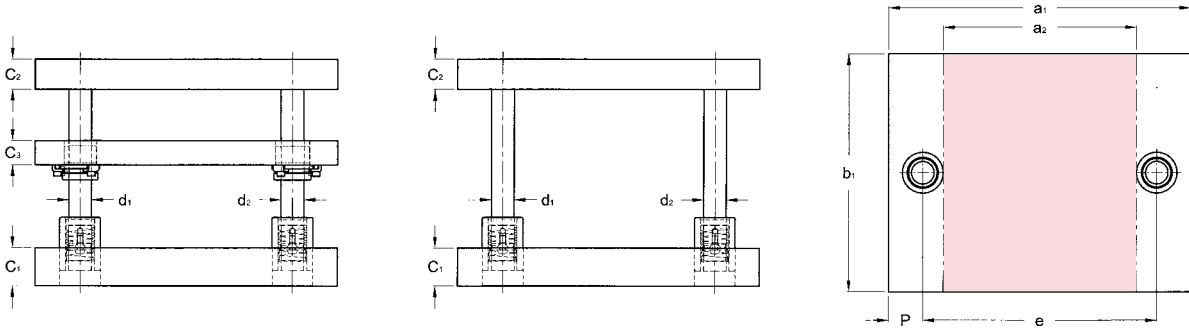

Standard assembly of bushes on stripper plate :

- on underside for demountable guide bushes (B1x.xxx.xxx and B2x.xxx.xxx)
- on top side for ball bearing guide bushes (B4x.xxx.xxx)

Ext. dimensions			C ₁ ±1	C ₂ ±1	C ₃ ±1	d ₁ /L	d ₂ /L	e	P	Reference x = 8 : with C3 x = 9 : without C3
a ₁	b ₁	a ₂								
250	160	120	32	32	32	25/200	24/200	165	42,5	Dx6.125.016 Dx6.225.016 Dx6.325.016 Dx6.425.016
			32	40						
			40	32						
			40	40						
	200		32	32						
			32	40						
			40	32						
			40	40						
	250		32	32						
			32	40						
			40	32						
			40	40						
315	200	170	32	32	32	32/200	30/200	224	45,5	Dx6.131.020 Dx6.231.020 Dx6.331.020 Dx6.431.020
			32	40						
			40	32						
			40	40						
	250		32	32						
			32	40						
			40	32						
			40	40						
	315		40	40						
			40	50						
			50	40						
			50	50						
400	200	255	40	40	32	32/200	30/200	309	45,5	Dx6.140.020 Dx6.240.020 Dx6.340.020 Dx6.440.020
			40	50						
			50	40						
			50	50						
	250		40	40						
			40	50						
			50	40						
			50	50						
	315		40	40						
			40	50						
			50	40						
			50	50						
400	40	40								
	40	50								
	50	40								
	50	50								

L : Pin Length recommendations

The plates are torch-cut and stress relieved.
The guide elements with ball bearings (bush B30.xxx.xxx) can be chosen from our "Guide Elements" catalogue.

Please note: The work space is reduced if B40 or B42 bushes are used (see pages 9 and 10 - position of clamps - dimensions Q1 and Q2).

Delivery: 72 hours ex works

Examples

Die set with stripper plate: **D86.463.040**
Identical die set without stripper plate: **D96.463.040**

Ext. dimensions			C ₁ ±1	C ₂ ±1	C ₃ ±1	d ₁ /L	d ₂ /L	e	P	Reference x = 8 : with C3 x = 9 : without C3
a ₁	b ₁	a ₂								
Work space										
500	250	330	40	40	32	40/220	38/220	395	52,5	Dx6.150.025
			40	50						Dx6.250.025
			50	40						Dx6.350.025
			50	50						Dx6.450.025
	315		40	40						Dx6.150.031
			40	50						Dx6.250.031
			50	40						Dx6.350.031
			50	50						Dx6.450.031
	400		40	40						Dx6.150.040
			40	50						Dx6.250.040
			50	40						Dx6.350.040
			50	50						Dx6.450.040
500	40	40	Dx6.150.050							
	40	50	Dx6.250.050							
	50	40	Dx6.350.050							
	50	50	Dx6.450.050							
630	315	429	50	50	40	50/220	48/220	510	60	Dx6.163.031
			50	58						Dx6.263.031
			58	50						Dx6.363.031
			58	58						Dx6.463.031
	400		50	50						Dx6.163.040
			50	58						Dx6.263.040
			58	50						Dx6.363.040
			58	58						Dx6.463.040
	500		50	50						Dx6.163.050
			50	58						Dx6.263.050
			58	50						Dx6.363.050
			58	58						Dx6.463.050
630	50	50	Dx6.163.063							
	50	58	Dx6.263.063							
	58	50	Dx6.363.063							
	58	58	Dx6.463.063							
710	400	509	58	58	40	50/250	48/250	590	60	Dx6.171.040
			58	63						Dx6.271.040
			63	58						Dx6.371.040
			63	63						Dx6.471.040
	500		58	58						Dx6.171.050
			58	63						Dx6.271.050
			63	58						Dx6.371.050
			63	63						Dx6.471.050
	630		58	58						Dx6.171.063
			58	63						Dx6.271.063
			63	58						Dx6.371.063
			63	63						Dx6.471.063

L : Pin Length recommendations

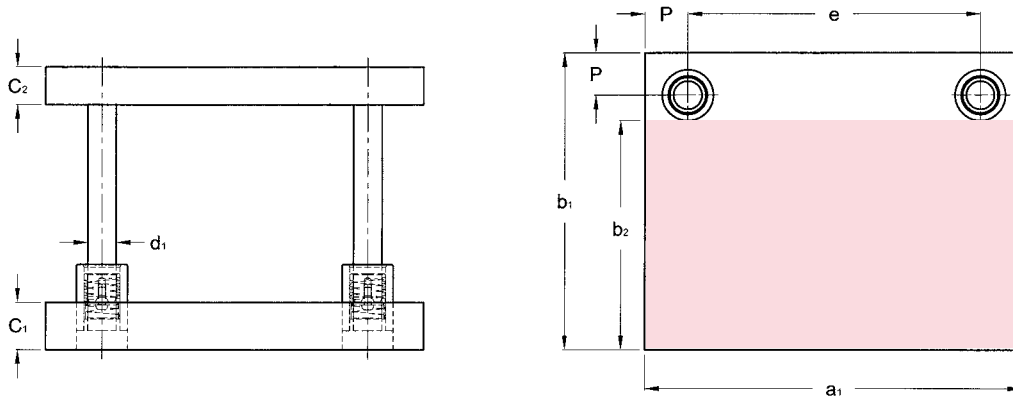

Ext. dimensions			C ₁ ±1	C ₂ ±1	d ₁ /L	e	P	Reference
a ₁	b ₂	b ₁						
Work space								
250	93	160	32	32	32/200	170	40	D97.125.016
			32	40				D97.225.016
			40	32				D97.325.016
			40	40				D97.425.016
	133	200	32	32				D97.125.020
			32	40				D97.225.020
			40	32				D97.325.020
			40	40				D97.425.020
	183	250	32	32				D97.125.025
			32	40				D97.225.025
			40	32				D97.325.025
			40	40				D97.425.025
315	128	200	32	32	32/200	225	45	D97.131.020
			32	40				D97.231.020
			40	32				D97.331.020
			40	40				D97.431.020
	178	250	32	32				D97.131.025
			32	40				D97.231.025
			40	32				D97.331.025
			40	40				D97.431.025
	243	315	40	40				D97.131.031
			40	50				D97.231.031
			50	40				D97.331.031
			50	50				D97.431.031
400	128	200	40	40	32/220	310	45	D97.140.020
			40	50				D97.240.020
			50	40				D97.340.020
			50	50				D97.440.020
	178	250	40	40				D97.140.025
			40	50				D97.240.025
			50	40				D97.340.025
			50	50				D97.440.025
	230	315	40	40				D97.140.031
			40	50				D97.240.031
			50	40				D97.340.031
			50	50				D97.440.031
	315	400	40	40				D97.140.040
			40	50				D97.240.040
			50	40				D97.340.040
			50	50				D97.440.040
400	230	315	40	40	40/220	295	52,5	D97.140.031
			40	50				D97.240.031
			50	40				D97.340.031
			50	50				D97.440.031
	315	400	40	40				D97.140.040
			40	50				D97.240.040
			50	40				D97.340.040
			50	50				D97.440.040

L : Pin Length recommendations

The plates are torch-cut and stress relieved.
The guide elements with ball bearings (bush B30.xxx.xxx) can be chosen from our "Guide Elements" catalogue.

Please note: The work space is reduced if B40 bushes are used
(see pages 9 - position of clamps - dimensions Q1 and Q2).

Delivery: 72 hours ex works

Example

Rectangular stock die set with
rear ball bearing guides:

D97.350.040

Ext. dimensions			C ₁ ±1	C ₂ ±1	d ₁ /L	e	P	Reference
a ₁	b ₂	b ₁						
Work space								
500	157	250	40	40	40/220	395	52,5	D97.150.025
			40	50				D97.250.025
			50	40				D97.350.025
			50	50				D97.450.025
	222	315	40	40				D97.150.031
			40	50				D97.250.031
			50	40				D97.350.031
			50	50				D97.450.031
	307	400	40	40				D97.150.040
			40	50				D97.250.040
			50	40				D97.350.040
			50	50				D97.450.040
407	500	40	40	D97.150.050				
		40	50	D97.250.050				
		50	40	D97.350.050				
		50	50	D97.450.050				
630	206	315	50	50	50/220	510	60	D97.163.031
			50	58				D97.263.031
			58	50				D97.363.031
			58	58				D97.463.031
	291	400	50	50				D97.163.040
			50	58				D97.263.040
			58	50				D97.363.040
			58	58				D97.463.040
	391	500	50	50				D97.163.050
			50	58				D97.263.050
			58	50				D97.363.050
			58	58				D97.463.050
521	630	50	50	D97.163.063				
		50	58	D97.263.063				
		58	50	D97.363.063				
		58	58	D97.463.063				
710	291	400	58	58	50/250	590	60	D97.171.040
			58	63				D97.271.040
			63	58				D97.371.040
			63	63				D97.471.040
	391	500	58	58				D97.171.050
			58	63				D97.271.050
			63	58				D97.371.050
			63	63				D97.471.050
	521	630	58	58				D97.171.063
			58	63				D97.271.063
			63	58				D97.371.063
			63	63				D97.471.063

L : Pin Length recommendations

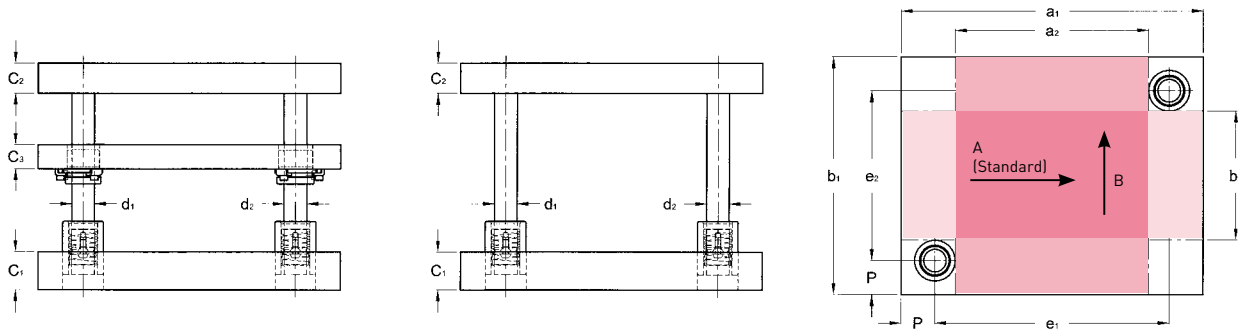

Standard assembly of bushes on stripper plate :
 - on underside for demountable guide bushes (B1x.xxx.xxx and B2x.xxx.xxx)
 - on top side for ball bearing guide bushes (B4x.xxx.xxx)

Ext. dimensions				C ₁ ±1	C ₂ ±1	C ₃ ±1	d ₁ /L	d ₂ /L	e ₁	e ₂	P	Reference x = 8 : with C3 x = 9 : without C3															
Work space, direction A		Work space, direction B																									
a ₁	b ₂	b ₁	a ₂																								
250	30	160	120	32	32	32	25/200	24/200	165	75	42,5	Dx8.125.016 Dx8.225.016 Dx8.325.016 Dx8.425.016															
				32	40																						
				40	32																						
				40	40																						
	70	200		250	32								32	32	25/200	24/200	165	115	42,5	Dx8.125.020 Dx8.225.020 Dx8.325.020 Dx8.425.020							
					32								40														
					40								32														
					40								40														
	120	250		315	32								32								32	25/200	24/200	165	165	42,5	Dx8.125.025 Dx8.225.025 Dx8.325.025 Dx8.425.025
					32								40														
					40								32														
					40								40														
315	56	200	171	32	32	32	32/200	30/200	225	110	45	Dx8.131.020 Dx8.231.020 Dx8.331.020 Dx8.431.020															
				32	40																						
				40	32																						
				40	40																						
	106	250		315	32								32	32	32/200	30/200	225	160	45	Dx8.131.025 Dx8.231.025 Dx8.331.025 Dx8.431.025							
					32								40														
					40								32														
					40								40														
	171	315		400	40								40								32	32/200	30/200	225	225	45	Dx8.131.031 Dx8.231.031 Dx8.331.031 Dx8.431.031
					40								50														
					50								40														
					50								50														
400	56	200	260	40	40	32	32/200	30/200	310	110	45	Dx8.140.020 Dx8.240.020 Dx8.340.020 Dx8.440.020															
				40	50																						
				50	40																						
				50	50																						
	106	250		315	40								40	32	32/200	30/200	310	160	45	Dx8.140.025 Dx8.240.025 Dx8.340.025 Dx8.440.025							
					40								50														
					50								40														
					50								50														
	171	315		400	40								40								32	32/200	30/200	225	225	45	Dx8.140.031 Dx8.240.031 Dx8.340.031 Dx8.440.031
					40								50														
					50								40														
					50								50														
256	400	400	40	40	32	32/200	30/200	310	310	45	Dx8.140.040 Dx8.240.040 Dx8.340.040 Dx8.440.040																
			40	50																							
			50	40																							
			50	50																							

L : Pin Length recommendations

The plates are torch-cut and stress relieved.
The guide elements with ball bearings (bush B30.xxx.xxx) can be chosen from our "Guide Elements" catalogue.

Please note: The work space is reduced if B40 bushes are used
(see page 9 and 10 - position of clamps - dimensions Q1 and Q2).

Delivery: 72 hours ex works

Examples

Die set with stripper plate: D88.125.016
Identical die set without stripper plate: D98.125.016

Ext. dimensions				C ₁ ±1	C ₂ ±1	C ₃ ±1	d ₁ /L	d ₂ /L	e ₁	e ₂	P	Reference x = 8 : with C3 x = 9 : without C3						
Work space, direction A		Work space, direction B																
a ₁	b ₂	b ₁	a ₂															
500	80	250	330	40	40	32	40/220	38/220	395	145	52,5	Dx8.150.025						
				40	50							Dx8.250.025						
				50	40							Dx8.350.025						
				50	50							Dx8.450.025						
	145	315		315	40					40		32	40/220	38/220	395	210	52,5	Dx8.150.031
					40					50								Dx8.250.031
					50					40								Dx8.350.031
					50					50								Dx8.450.031
	230	400		400	40					40		32	40/220	38/220	395	295	52,5	Dx8.150.040
					40					50								Dx8.250.040
					50					40								Dx8.350.040
					50					50								Dx8.450.040
330	500	500	40	40	32	40/220	38/220	395	395	52,5	Dx8.150.050							
			40	50							Dx8.250.050							
			50	40							Dx8.350.050							
			50	50							Dx8.450.050							
630	114	315	429	50	50	40	50/220	48/220	510	195	60	Dx8.163.031						
				50	58							Dx8.263.031						
				58	50							Dx8.363.031						
				58	58							Dx8.463.031						
	199	400		400	50					50		40	50/220	48/220	510	280	60	Dx8.163.040
					50					58								Dx8.263.040
					58					50								Dx8.363.040
					58					58								Dx8.463.040
	299	500		500	50					50		40	50/220	48/220	510	380	60	Dx8.163.050
					50					58								Dx8.263.050
					58					50								Dx8.363.050
					58					58								Dx8.463.050
429	630	630	50	50	40	50/220	48/220	510	510	60	Dx8.163.063							
			50	58							Dx8.263.063							
			58	50							Dx8.363.063							
			58	58							Dx8.463.063							
710	199	400	509	58	58	40	50/250	48/250	590	280	60	Dx8.171.040						
				58	63							Dx8.271.040						
				63	58							Dx8.371.040						
				63	63							Dx8.471.040						
	299	500		500	58					58		40	50/250	48/250	590	380	60	Dx8.171.050
					58					63								Dx8.271.050
					63					58								Dx8.371.050
					63					63								Dx8.471.050
	429	630		630	58					58		40	50/250	48/250	590	510	60	Dx8.171.063
					58					63								Dx8.271.063
					63					58								Dx8.371.063
					63					63								Dx8.471.063

L : Pin Length recommendations

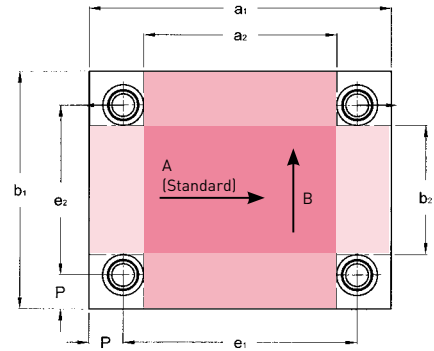
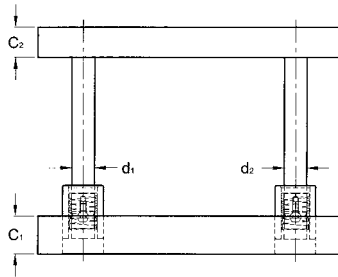
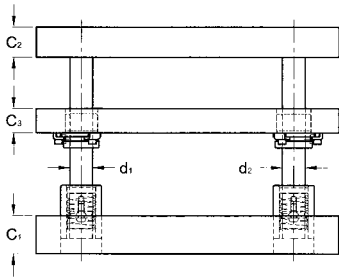

Standard assembly of bushes on stripper plate :
 - on underside for demountable guide bushes (B1x.xxx.xxx and B2x.xxx.xxx)
 - on top side for ball bearing guide bushes (B4x.xxx.xxx)

Ext. dimensions				C ₁ ±1	C ₂ ±1	C ₃ ±1	d ₁ /L	e ₁	e ₂	P	Reference x = 8 : with C3 x = 9 : without C3					
Work space, direction A		Work space, direction B														
a ₁	b ₂	b ₁	a ₂													
250	30	160	120	32	32	32	25/200	165	75	42,5	Dx9.125.016 Dx9.225.016 Dx9.325.016 Dx9.425.016					
				32	40											
				40	32											
				40	40											
	70	200		120	32				32		32	25/200	165	115	42,5	Dx9.125.020 Dx9.225.020 Dx9.325.020 Dx9.425.020
					32				40							
					40				32							
					40				40							
					40				40							
120	250	250	32	32	32	25/200	165	165	42,5	Dx9.125.025 Dx9.225.025 Dx9.325.025 Dx9.425.025						
			32	40												
			40	32												
			40	40												
			40	40												
			40	40												
315	70	200	185	32	32	32	25/200	230	115	42,5	Dx9.131.020 Dx9.231.020 Dx9.331.020 Dx9.431.020					
				32	40											
				40	32											
				40	40											
	120	250		250	32				32		32	25/200	230	165	42,5	Dx9.131.025 Dx9.231.025 Dx9.331.025 Dx9.431.025
					32				40							
					40				32							
					40				40							
	185	315		315	40				40		32	25/200	230	230	42,5	Dx9.131.031 Dx9.231.031 Dx9.331.031 Dx9.431.031
					40				50							
					50				40							
					50				50							
400	70	200	270	40	40	32	25/200	315	115	42,5	Dx9.140.020 Dx9.240.020 Dx9.340.020 Dx9.440.020					
				40	50											
				50	40											
				50	50											
	120	250		250	40				40		32	25/200	315	165	42,5	Dx9.140.025 Dx9.240.025 Dx9.340.025 Dx9.440.025
					40				50							
					50				40							
					50				50							
	165	315	315	40	40	32	32/220	304	219	48	Dx9.140.031 Dx9.240.031 Dx9.340.031 Dx9.440.031					
				40	50											
				50	40											
				50	50											
	250	400	400	40	40	32	32/220	304	304	48	Dx9.140.040 Dx9.240.040 Dx9.340.040 Dx9.440.040					
				40	50											
				50	40											
				50	50											

L : Pin Length recommendations

The plates are torch-cut and stress relieved.
The guide elements with ball bearings (bush B30.xxx.xxx) can be chosen from our "Guide Elements" catalogue.

Please note: The work space is reduced if B40 bushes are used
(see pages 9 and 10 - position of clamps - dimensions Q1 and Q2).

Delivery: 72 hours ex works

Examples

Die set with stripper plate: D89.125.016
Identical die set without stripper plate: D99.125.016

Ext. dimensions				C ₁ ±1	C ₂ ±1	C ₃ ±1	d ₁ /L	e ₁	e ₂	P	Reference x = 8 : with C3 x = 9 : without C3
Work space, direction A		Work space, direction B									
a ₁	b ₂	b ₁	a ₂								
500	100	250	350	40	40	32	32/220	404	154	48	Dx9.150.025
				40	50						Dx9.250.025
				50	40						Dx9.350.025
				50	50						Dx9.450.025
	165	315		40	40				Dx9.150.031		
				40	50				Dx9.250.031		
				50	40				Dx9.350.031		
				50	50				Dx9.450.031		
	250	400		40	40				Dx9.150.040		
				40	50				Dx9.250.040		
				50	40				Dx9.350.040		
				50	50				Dx9.450.040		
350	500	40	40	Dx9.150.050							
		40	50	Dx9.250.050							
		50	40	Dx9.350.050							
		50	50	Dx9.450.050							
630	140	315	455	50	50	40	40/220 520	520	205	55	Dx9.163.031
				50	58						Dx9.263.031
				58	50						Dx9.363.031
				58	58						Dx9.463.031
	225	400		50	50				Dx9.163.040		
				50	58				Dx9.263.040		
				58	50				Dx9.363.040		
				58	58				Dx9.463.040		
	325	500		50	50				Dx9.163.050		
				50	58				Dx9.263.050		
				58	50				Dx9.363.050		
				58	58				Dx9.463.050		
455	630	50	50	Dx9.163.063							
		50	58	Dx9.263.063							
		58	50	Dx9.363.063							
		58	58	Dx9.463.063							
710	190	400	500	58	58	40	50/250	581	271	64,5	Dx9.171.040
				58	63						Dx9.271.040
				63	58						Dx9.371.040
				63	63						Dx9.471.040
	290	500		58	58				Dx9.171.050		
				58	63				Dx9.271.050		
				63	58				Dx9.371.050		
				63	63				Dx9.471.050		
	420	630		58	58				Dx9.171.063		
				58	63				Dx9.271.063		
				63	58				Dx9.371.063		
				63	63				Dx9.471.063		

L : Pin Length recommendations



DIE SETS - MACHINED PLATES ACCORDING TO DRAWING CONTENTS

■ Machine capacities	26
■ Special die sets	27
■ MDL geometric standards	28
■ Dimensioning instructions for special rectangular die sets	29

We perform machining on CNC machines.

CNC TORCH CUTTING Max. L x W x thickness: 6,000 x 2,300 x 250 mm
Tolerance to ± 2 mm

STRESS RELIEVING L x W x H max.: 4,500 x 2,300 x 1,600 mm
Max. load: 20 T

MACHINING

Grinding: Blancard and tangential-type. Max.load: 2T
Max. diagonal: 2,200 mm

Milling on machining centre

Max. stroke (X) : X x Y x Z: 3,650 x 1,750 x 710 mm	Max. load: 9 T
Max. stroke (Y and Z) : X x Y x Z: 3,000 x 2,500 x 1,000 mm	Max. load: 6 T
Large capacity : X x Y x Z: 4,010 x 2,500 x 670 mm	Max. load: 15 T

Deep drilling

Max. stroke : X x Y x Z: 2,000 x 1,000 x 1,500 mm	Max. load: 15 T
---	-----------------

Boring, Drilling, Edge milling, etc.

MECHANICAL WELDING can be carried out upon demand

HANDLING

Bridge cranes of up to 20 T

STEEL PLATE SPECIFICATIONS

In stock: C25 - C45

Upon demand: Pre-treated steel, high-strength aluminium, etc.

Stress relieving upon request.

TYPES OF PLATES

The peripheral shapes are torch-cut and deburred.

The edges may be milled for reference surfaces.

If tolerances are not specified for the thickness, the plates will be spotfaced to the minimum extent, i.e. the blank sheet of the specified thickness

is ground until our standards of flatness and parallel alignment are obtained

Spot facing = 0 to 3 mm/metre max.

DIE SETS WITH TORCH-CUTTING AND MACHINING ACCORDING TO DRAWING

We manufacture die sets according to your drawing and design specifications.

Heavy machining removing a lot of metal, carried out after the die set has been assembled, may cause deformations. We recommend that you let us perform these machining operations.

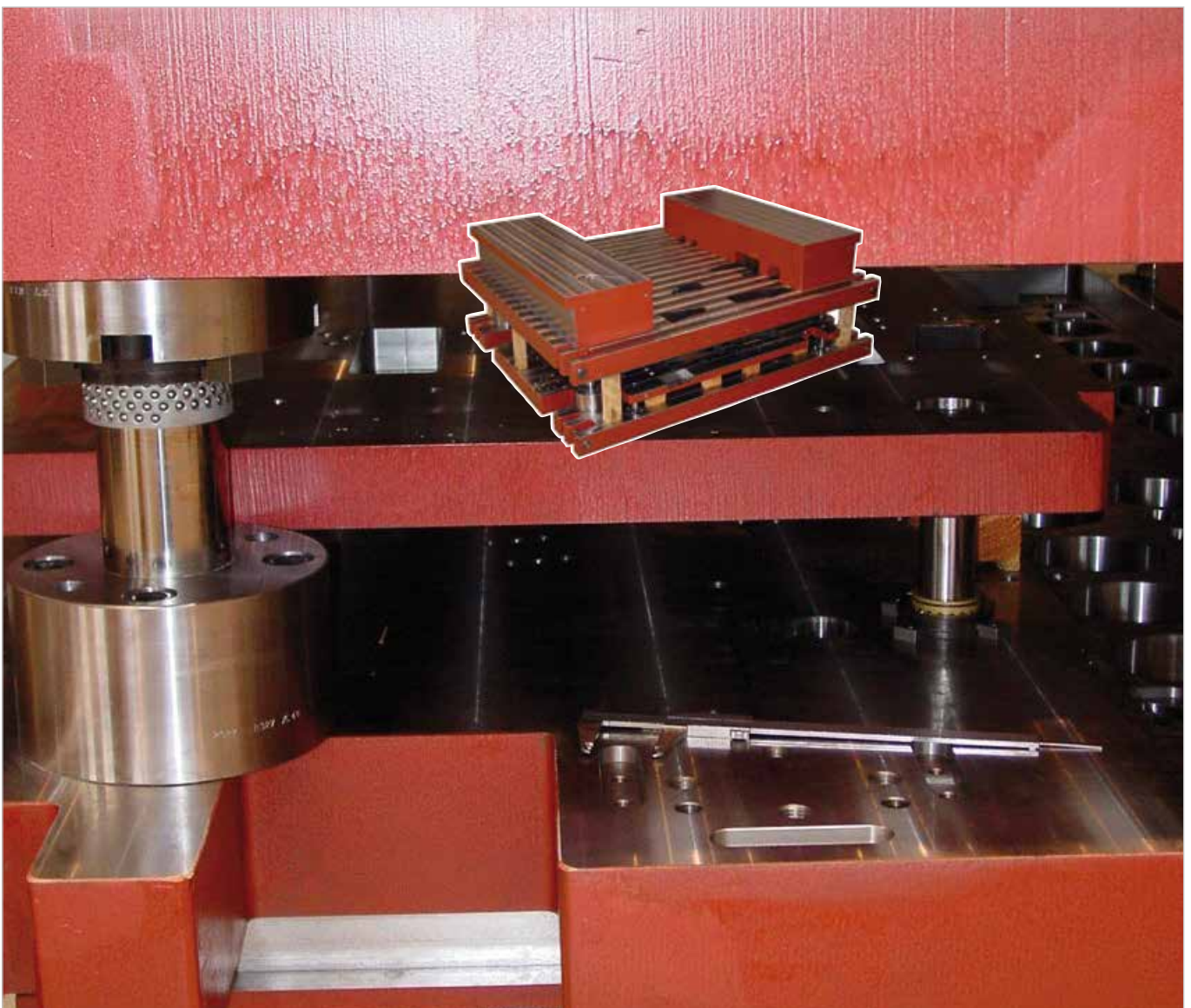

FLATNESS OF PLATE FACES

Thickness	TE
E > 30mm	0,004 / 100 mm
20 < E < 30 mm	0,008 / 100 mm

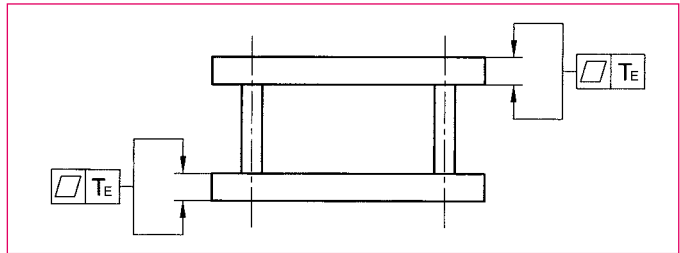

PARALLEL ALIGNMENT OF PLATE FACES

from mm	to mm	TP
0	100	0,006
100	200	0,012
200	300	0,018

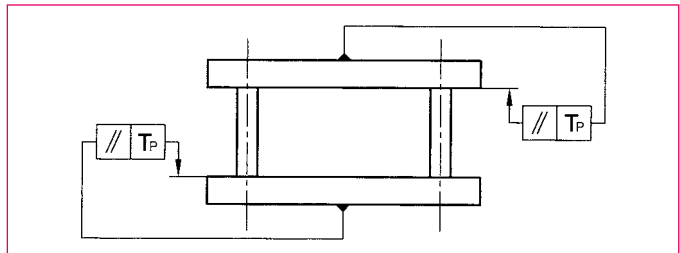

PARALLEL ALIGNMENT OF EXTERNAL FACES OF DIE SET

from mm	to mm	TP
0	100	0,008
100	200	0,012
200	300	0,018
300	400	0,024
400	500	0,030
500	600	0,036

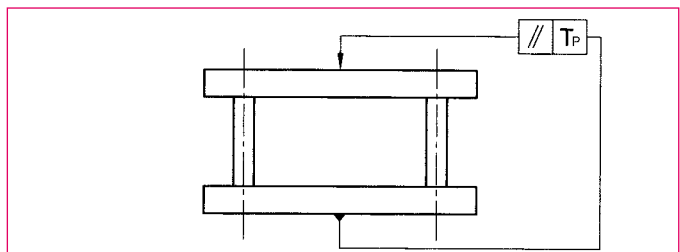

LOCATION

TA: ±12 µm/m + additional 5 µm/m

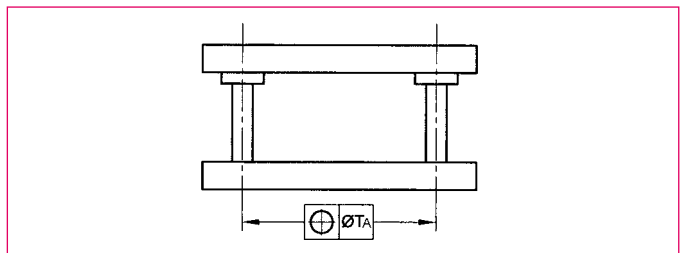

PERPENDICULARITY

TW
0,015 / 100mm

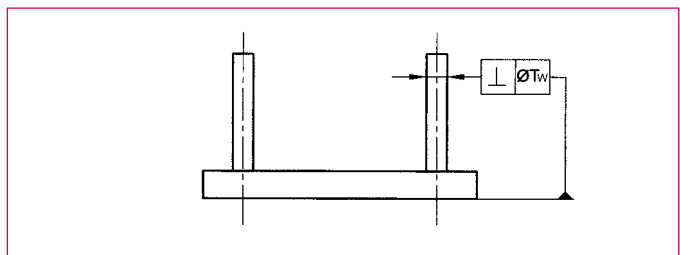

ADJUSTMENT OF BORES

Guide pillar	Guide bush
d = R6	D = H6

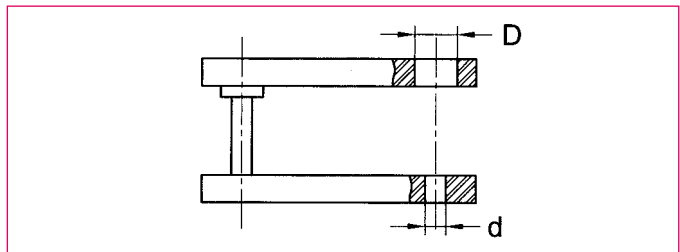
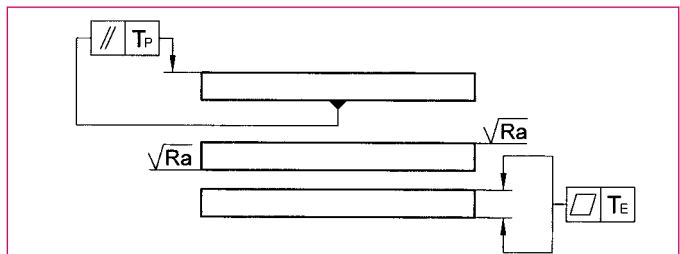

PLATE WITH MIN. SPOTFACING

TE	TP	RA
0,04/1000 mm	0,06/1000 mm	3,2



DIMENSIONING INSTRUCTIONS FOR SPECIAL RECTANGULAR DIE SETS

RECOMMENDED PILLAR DIAMETER ACCORDING TO LENGTH A1 OF PLATE

Length a1	150 - 300	350 - 500	550 - 700	750 - 1000	1100 - 1900	2000 - 2500
Recommended d1	25	32	40	50	63	80

DIRECTION OF MOVEMENT - A - LEFT - RIGHT

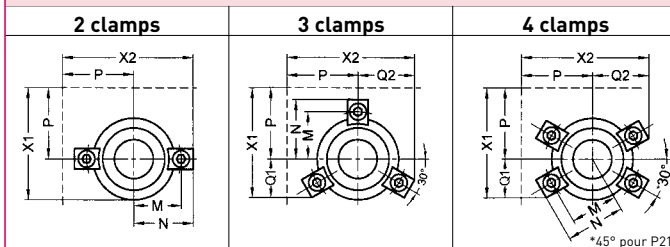

DIRECTION OF MOVEMENT - B - FRONT - BACK

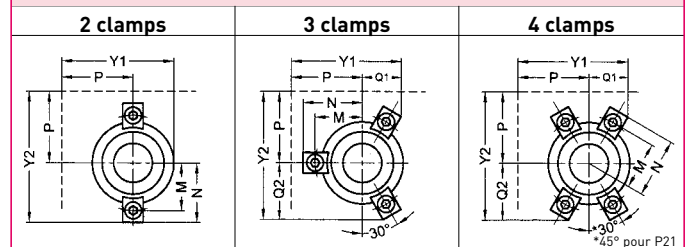

STANDARD POSITION OF GUIDES AND FIXINGS

		GUIDE PILLAR P10 - P21 - P22						
Diameter		19 - 20	24 - 25	30 - 32	38 - 40	48 - 50	63	80
no. of P21 clamps		3 x M5	3 x M6	3 x M6	4 x M8	4 x M8	4 x M8	4 x M8
		GUIDE BUSH B10 - B20						
P		30	40	45	50	60	65	75
X1 / Y1		46,3	64,2	71	81,5	97,5	111,5	132,5
X2 / Y2		55,5	74	82	94,1	112,3	122	141,6
no. of clamps		2 x M5	3 x M6	3 x M6	4 x M8	4 x M8	4 x M8	4 x M8
		GUIDE BUSH B12 - B22						
P		30	40	45	50	60	65	75
X1 / Y1		46,3	65,3	72	83,8	97,5	102,5	132,5
X2 / Y2		55,5	76,6	84,6	99	114,2	127,5	146,6
no. of clamps		2 x M5	3 x M6	3 x M6	4 x M8	4 x M8	4 x M8	4 x M8
		BALL BEARING GUIDE BUSH B30 - B40						
P		-	45	50	55	65	70	80
X1 / Y1		-	71	81,5	92,5	111,5	124	142,5
X2 / Y2		-	82	94,1	104,3	122	134	151,8
no. of B40 clamps		-	3 x M6	3 x M8	4 x M8	4 x M8	4 x M8	4 x M8
		BALL BEARING GUIDE BUSH intermediate plate B42						
P		-	45	50	55	65	-	-
X1 / Y1		-	72	79,3	92,5	111,5	-	-
X2 / Y2		-	84,6	93,5	103,7	121,5	-	-
no. of clamps		-	3 x M6	3 x M6	4 x M6	4 x M6	-	-

RECOMMENDED PLATE THICKNESS ACCORDING TO TYPE OF GUIDE ELEMENT USED









Diameter	P10	P21	P22	B10-B20	B12-B22	B30	B40	B42	Plates
19 - 20	25	25	38	-	-	-	-	-	C1
	20	20	30	20	20	-	-	-	C2
	-	-	-	20	20	-	-	-	C3
24 - 25	32	32	46	-	-	32	32	-	C1
	25	25	38	25	25	32	32	-	C2
	-	-	-	25	25	-	-	22	C3
30 - 32	40	40	56	-	-	40	40	-	C1
	32	32	48	28	32	40	40	-	C2
	-	-	-	25	28	-	-	22	C3
38 - 40	50	50	66	-	-	50	50	-	C1
	40	40	58	32	40	50	50	-	C2
	-	-	-	32	50	-	-	32	C3
48 - 50	58	58	76	-	-	58	58	-	C1
	50	50	68	38	50	58	58	-	C2
	-	-	-	32	50	-	-	38	C3
63	63	63	86	-	-	63	63	-	C1
	58	58	78	50	63	63	63	-	C2
	-	-	-	40	63	-	-	-	C3
80	68	68	98	-	-	-	-	-	C1
	60	60	92	50	80	-	-	-	C2
	-	-	-	40	80	-	-	-	C3

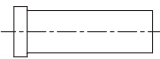
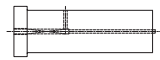

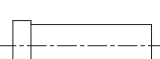
Punches and dies



HEADED PUNCHES

P_-PPN		Standard ISO 8020 Without ejector	35
P_-PPE		Standard ISO 8020 With ejector	36
P_-PPD		Center dowel Without ejector	37
P_-PPF		Center dowel With ejector	38
P_-PTN		For heavy duty Without ejector	39
P_-PTE		For heavy duty With ejector	40
P_-PTD		Center dowel Without ejector	41
P_-PTF		Center dowel With ejector	42
PB-PAN		Standard DIN 9844 Without ejector	43
P_-PSN		Micro punches	44
PB-PPNP P_-PPNZ		Pilots	45

TAPERED HEAD PUNCHES

PB-RFN		Without ejector DIN 5118	46
PB-RFE		With ejector DIN 5118	47

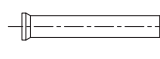
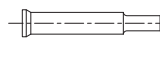
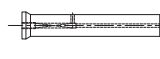
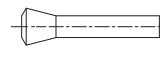
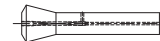

CONICAL HEAD PUNCHES

P_-TFNB		60° - Standard DIN 9861D Without ejector - Blank	48
P_-TFN		60° - Standard DIN 9861D Without ejector	49
P_-TFE		60° - Standard DIN 9861D With ejector	50
P_-TTN		30° - Without ejector	51
P_-TTE		30° - With ejector	52

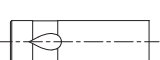
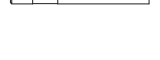
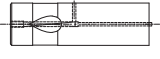

BALL-LOCK PUNCHES

P_-BLN	Light duty		Ball-Lock - Without ejector	53
P_-BHN	Heavy duty			
P_-BLE	Light duty		Ball-Lock - With ejector	54
P_-BHE	Heavy duty			
P_-BJN	Light duty		Point larger than shank	55
P_-BKN	Heavy duty			



STRAIGHT DIE BUTTON - STANDARD ISO 8977

D_-SMWB		Blank	57
D_-SMD		Taper relief	57
D_-SMC		Counterbore relief	58

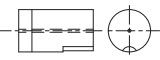
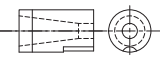

HEADED DIE BUTTON - STANDARD ISO 8977

D_-HMWB		Blank	59
D_-HMD		Taper relief	59
D_-HMC		Counterbore relief	60

KEY LOCATED DIE BUTTON - STANDARD ISO 8977

DA-SCWB		Blank	61
DA-SCD		Taper relief	61
DA-SCC		Counterbore relief	62







LOW PROFILE DIE BUTTON

DA-SR__		Key located - reversible	63
D_-SS__		Key located	64

BALL-LOCK DIE BUTTON - STANDARD NFE 63-102

DA-BLC		Ball-lock die button	65
---------------	--	----------------------	-----------

ACCESSORIES

YR-SRSC		Precision screw	66
YR-SCCL		Clamp for headless die button	66
YR-SSCL		Clamp for SS die button	66
YR-RFSE		Seat for tapered head punches	66
Y_-RFMT		Machining tool for tapered head punches	66
YF-SAC		Sharpening spacers	67
YU-SSCR		Urethane strippers	68

ISO PUNCH RETAINERS FOR HEADED PUNCHES

RR-PPT		Standard ISO Light duty	69
RR-PPV		Standard ISO High height	70
RR-PTH		Standard ISO Heavy duty	71





PUNCH RETAINERS FOR TAPERED HEAD PUNCHES

RR-RFFS		Reduced punch retainers	72
----------------	---	-------------------------	-----------



BALL-LOCK PUNCH RETAINERS

RR-BLTN Light duty		NFE 63 -103	73
RR-BHTN Heavy duty		Ball-Lock	73
RT-BLSN Light duty		NFE 63 -103	74
		Ball-Lock with shock plate	
RT-BLRN Light duty		NFE 63 -103	74
		Ball-Lock with shock plate	

AFNOR PUNCH RETAINERS FOR HEADED PUNCHES

RT-PPT		NFE 63 -117 Reduced dimensions	75
RT-PPS		NFE 63-108 Square shape	76
RT-PPR		NFE 63-107 Rectangle shape	77
RZ-PPPH		Punch retainers Retractable	78
RR-XXXX		Special punch retainers	79

DIE RETAINERS

RR-BLSN Light duty		NFE 63 -103	80
		Ball-Lock without shock plate	
RR-BLRN Light duty		NFE 63 -104	80
		Ball-Lock without shock plate	

CLASSIFIED SHAPED CONCAVE - CONVEX

TMX AND TMY SHAPED PUNCHES AND DIES - SPECIALS	81
---	-----------

PUNCHES - TECHNICAL OPTIONS

FLAT LOCATION	83
DOWEL LOCATION	83
OPTIMISATION	83
TOLERANCE MODIFICATIONS	84
DIMENSIONAL MODIFICATIONS	85
SHEAR ANGLES	85

DIE BUTTONS - TECHNICAL OPTIONS

FLAT LOCATION	86
DOWEL LOCATION	87
WASTE RETENTION	88
TOLERANCE MODIFICATIONS	88
DIMENSIONAL MODIFICATIONS	89

ADDITIONAL TECHNICAL INFORMATIONS

COATINGS	90
CUTTING CLEARANCE - RECOMMANDATIONS	90

PUNCHES CODIFICATIONS

B = Material

X155CrVMo12.1/1.2379/HWS/D2	A
Z90/HSS/1.3343/M2/HS 6.5.2	B
Carbure	C
ASP23/1.3395/M32/HS 6.5.3	E
XII0CrMoV8-2	K
M4/1.3351/HS 6.5.4	S

N =

Solid punch	N
Ejector punch	E
Center dowel without ejector	D
Center dowel with ejector	F

P = Metric Punch
(Q = inches dimensions)

Ø Body (mm)

Total length (mm)

L2 Working Length

PB-PPNL-10-120-25-P6.2-W4.8

P - W Shape dimensions

PP = Type

Special	XX
Headed punches, 3mm Thick Body tol m5	PS
Headed punches , Body tol h6 (DIN 9844)	PA
Headed punches, 5mm Thick Body tol m5 (ISO 8020)	PP
Headed punches , 5mm Thick Body tol m4	PV
Headed punches, 5mm Thick Body tol m5 (CNOMO)	PM
Headed punches , 8mm Thick Body tol m5	PT
Headed punches, 10mm Thick Body tol m5	PN
Conical head punches 60° Body tol h6 ISO 6752	TF
Conical head punches 30° Body tol h6	TT
Tapered head punches Body tol h6	RF
Headless punches Body tol h6	LH
Ball-lock punches, heavy duty	BH
Ball-lock punches, light duty	BL
Ball-lock punches, heavy duty "knob"	BK
Ball-lock punches, light-duty "knob"	BJ

L = Shapes

Blank	B
Blank with alteration	A
Round	S
Oblong	L
Square	V
Rectangle	R
Rounded rectangle	F
Hexagon	H
Positive Pick-up Pilots	Y
Straight Pilots	P
Pilots - PPNZ type	Z
Classified Shapes - TMX	T
Classified Shapes - TMY	E
Special	X

P_-PPNB
Blank

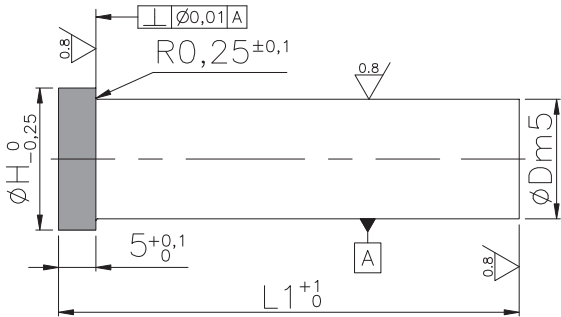

ØH = ØD + 3mm

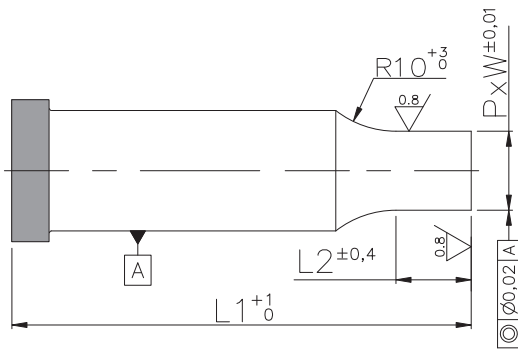

! $G = \sqrt{P^2 + W^2}$. $G \leq \text{ØD} - 0,1$

P_-PPNS
Round

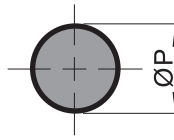

P_-PPNF
Rounded rectangle

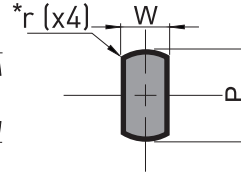

P_-PPNV
Square

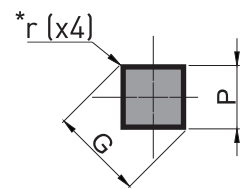

P_-PPNL
Oblong

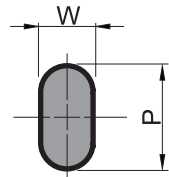

P_-PPNR
Rectangle

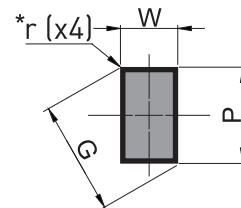

P_-PPNH
Hexagon

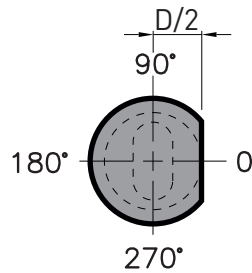
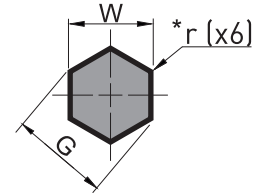

*Angle radius is r=0 by default
(If you want a radius of 1.5mm please specify r1.5)



Flat location on demand
Example : R2T0 Flat tangent to the body at 0°.

Alternate locations page 83

Reference	Ø D	L1				L2	P_-PPNS		Others shapes	
		71	80	100	120		ØP	W (min)	P / G (max)	
	4	B	B	B	B	10	1,0 - 3,9	1,5	3,9	
	5	B+E	B+E	B+E	B	10	1,0 - 4,9	1,5	4,9	
	6	B+E	B+E	B+E	B	10	1,5 - 5,9	1,5	5,9	
	7	B+E	B+E	B+E	B	10	2,0 - 6,9	1,7	6,9	
	8	B+E	B+E	B+E	B	13	2,5 - 7,9	2	7,9	
	9	B	B	B	B	13	3,5 - 8,9	2,7	8,9	
	10	A+B+E+S	A+B+E+S	A+B+E+S	B	13	4,5 - 9,9	3,5	9,9	
	11	B	B	B	B	13	5,1 - 10,9	3,8	10,9	
	12	B	B	B	B	16	5,8 - 11,9	4,2	11,9	
	13	A+B+E+S	A+B+E+S	A+B+E+S	B	16	6,5 - 12,9	4,5	12,9	
	14	B	B	B	B	16	7,5 - 13,9	5,1	13,9	
	15	B	B	B	B	20	8,5 - 14,9	5,7	14,9	
	16	A+B+E+S	A+B+E+S	A+B+E+S	B	20	9,5 - 15,9	6	15,9	
	20	A+B+E+S	A+B+E+S	A+B+E+S	B	20	12,5 - 19,9	8	19,9	
	25	A+B+E+S	A+B+E+S	A+B+E+S	B	20	16,5 - 24,9	10	24,9	
	32	A+B	A+B	A+B	B	20	22,5 - 31,9	12	31,9	
	40	B	B	B	B	20	30,5 - 39,9	14	39,9	

ØD and length "L1" : Others dimensions on request.

Length L2 applied by default, others dimensions on request.

Material	Body	Head
A = (X155CrVMo.12.1)	58 - 62	40 - 50 HRc
B = (Z90 WDCV 06050402)	60 - 64	47 - 57 HRc
E = (ASP23)	62 - 66	47 - 57 HRc
S = (M4)	62 - 66	47 - 57 HRc

To order :

Punch HSS ISO 8020 Solid Blank D/body L1
P B - P P N B - 16 - 71 Blank

Punch HSS ISO 8020 Solid Rectangle D/body L1 L2 Shape dimensions Flat Position
P B - P P N R - 16 - 71 - 20 - P12.2 - W7.2 - R2 - T90 Shaped

+ Other materials on request.
 Other cutting shapes (E ; T ; X) : page 81
 Available coatings : page 90
 Technical options : page 83

P_-PPEB
Blank

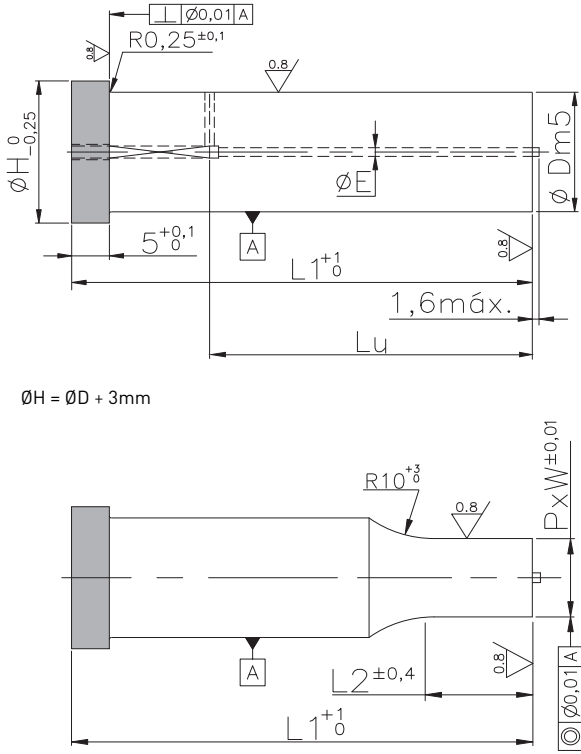

$\varnothing H = \varnothing D + 3\text{mm}$

! $G = \sqrt{P^2 + W^2}$. $G \leq \varnothing D - 0,1$

P_-PPES
Round

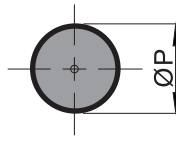

P_-PPEF
Rounded rectangle

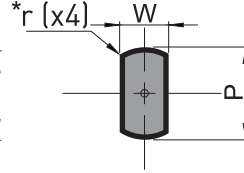

P_-PPEV
Square

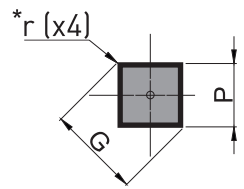

P_-PPEL
Oblong

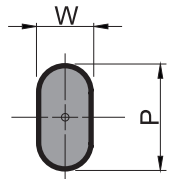

P_-PPER
Rectangle

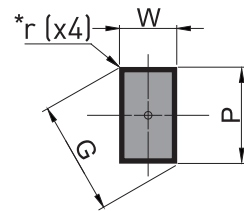

P_-PPEH
Hexagon

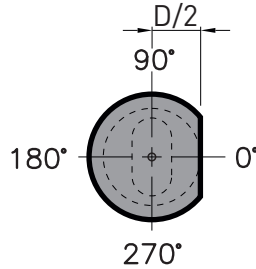
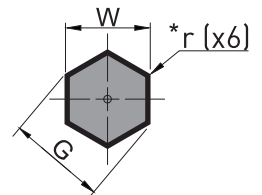

*Angle radius is r=0 by default
(If you want a radius of 1.5mm please specify r1.5)

Flat location on demand
Example : R2T0 Flat tangent to the body at 0°.



Alternate locations page 83

Reference	Ø D	L1				L2	ØE	P_-PPES	Others shapes	
		71	80	100	120			ØP	W (min)	P / G (max)
<p>Shapes: S, L, F, V, H</p> <p>Material: S, L, F, V, H, E, T, X</p> <p>(TMY) = E (TMX) = T (SPECIALS) = X</p>	5	B	B	B		10	1,1	1,0 - 4,9	2,5	4,9
	6	B	B	B		10	1,1	1,5 - 5,9	2,5	5,9
	8	B	B	B	B	13	1,1	2,5 - 7,9	3	7,9
	10	B	B	B	B	13	1,3	4,5 - 9,9	4,5	9,9
	13	B	B	B	B	16	1,3	6,5 - 12,9	6	12,9
	16	B	B	B	B	20	2,2	9,5 - 15,9	7	15,9
	20	B	B	B	B	20	2,2	12,5 - 19,9	8	19,9
	25	B	B	B	B	20	2,2	16,5 - 24,9	10	24,9
	32	B	B	B	B	20	2,2	22,5 - 31,9	12	31,9
	40	B	B	B	B	20	2,2	30,5 - 39,9	14	39,9
ØD and length "L1" : Others dimensions on request.		LU				<div style="border: 1px solid black; display: inline-block; width: 15px; height: 10px;"></div> Length L2 applied by default, others dimensions on request.				
		39	48	68	68					

Material	Body	Head
B = (Z90 WDCV 06050402)	60 - 64	47 - 57 HRc

+ Other materials on request.
Other cutting shapes (E ; T ; X) : page 81
Available coatings : page 90
Technical options : page 83

To order :

Punch HSS ISO 8020 Ejector Blank D/body L1
PB - PPEB - 16 - 71 Blank

Punch HSS ISO 8020 Ejector Rectangle D/body L1 L2 Shape dimensions Flat Position
PB - PPER - 16 - 71 - 20 - P12.2 - W8.2 - R2 - T90 Shaped

NEW

P_-PPDB
Blank

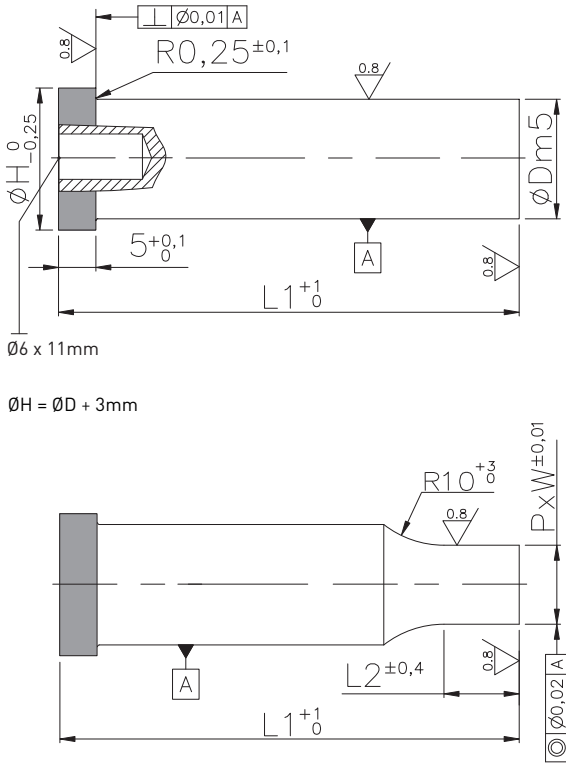

Ø6 x 11mm

ØH = ØD + 3mm

P_-PPDS
Round

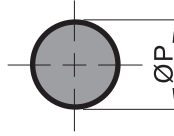

P_-PPDF
Rounded rectangle

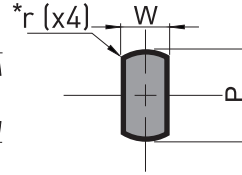

P_-PPDV
Square

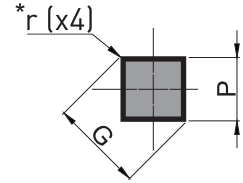

P_-PPDL
Oblong

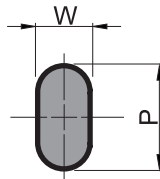

P_-PPDR
Rectangle

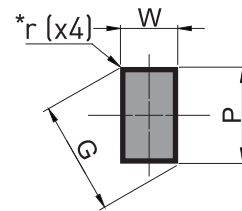

P_-PPDH
Hexagon

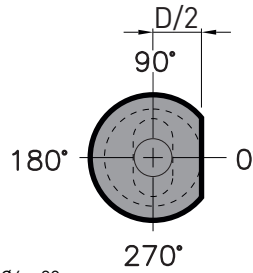
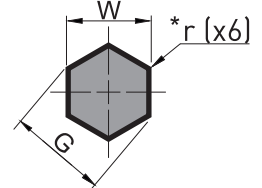

*Angle radius is r=0 by default
(If you want a radius of 1.5mm please specify r1.5)

Flat location on demand
Example : R2T0 Flat tangent to the body at 0°.



Alternate locations page 83



$$G = \sqrt{P^2 + W^2} \cdot G \leq \text{ØD} - 0,1$$

Delivered with dowel pins - Ø6 x 20mm
A20.006.020

Reference	Ø D	L1				L2	Others shapes		
		71	80	100	120		P_-PPDS ØP	W (min)	P / G (max)
Shapes Material PB - PPDR A E S (TMY) = E (TMX) = T (SPECIALS) = X	10	A+B+E+S	A+B+E+S	A+B+E+S	B	13	4,5 - 9,9	3,5	9,9
	11	B	B	B	B	13	5,1 - 10,9	3,8	10,9
	12	B	B	B	B	16	5,8 - 11,9	4,2	11,9
	13	A+B+E+S	A+B+E+S	A+B+E+S	B	16	6,5 - 12,9	4,5	12,9
	14	B	B	B	B	16	7,5 - 13,9	5,1	13,9
	15	B	B	B	B	20	8,5 - 14,9	5,7	14,9
	16	A+B+E+S	A+B+E+S	A+B+E+S	B	20	9,5 - 15,9	6	15,9
	20	A+B+E+S	A+B+E+S	A+B+E+S	B	20	12,5 - 19,9	8	19,9
	25	A+B+E+S	A+B+E+S	A+B+E+S	B	20	16,5 - 24,9	10	24,9
	32	A+B	A+B	A+B	B	20	22,5 - 31,9	12	31,9
40	B	B	B	B	20	30,5 - 39,9	14	39,9	

ØD and length "L1" : Others dimensions on request.

Length L2 applied by default, others dimensions on request.

Material	Body	Head
A = (X155CrVMo.12.1)	58 - 62	40 - 50 HRc
B = (Z90 WDCV 06050402)	60 - 64	47 - 57 HRc
E = (ASP23)	62 - 66	47 - 57 HRc
S = (M4)	62 - 66	47 - 57 HRc

To order :

Punch HSS 150 8020 Dowel Blank D/body L1
PB - PPDB - 16 - 71 Blank

Punch HSS 150 8020 Dowel Rectangle D/body L1 L2 Shape dimensions Flat Position
PB - PPDR - 16 - 71 - 20 - P12.2 - W8.2 - R2 - T90 Shaped

Other materials on request.
Other cutting shapes (E ; T ; X) : page 81
Available coatings : page 90
Technical options : page 83

NEW

P_-PPFB
Blank

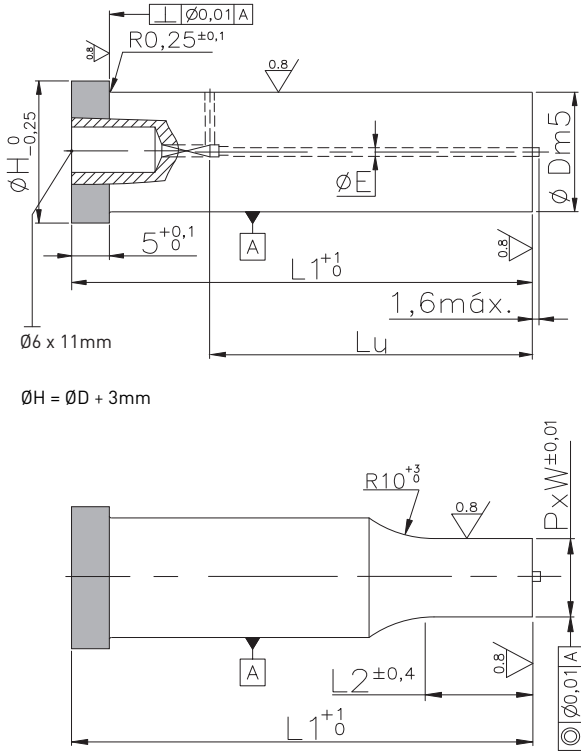

$\varnothing H = \varnothing D + 3\text{mm}$

P_-PPFS
Round

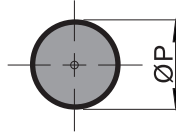

P_-PPFF
Rounded rectangle

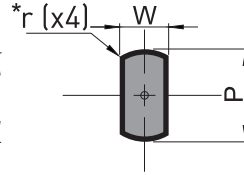

P_-PPFV
Square

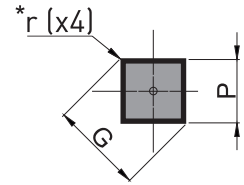

P_-PPFL
Oblong

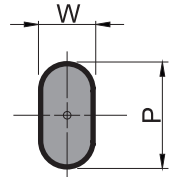

P_-PPFR
Rectangle

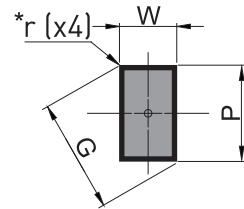

P_-PPFH
Hexagon

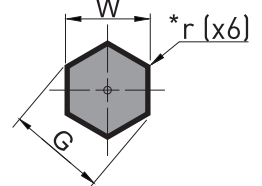

*Angle radius is r=0 by default
(If you want a radius of 1.5mm please specify r1.5)

Flat location on demand
Example : R2T0 Flat tangent to the body at 0°.

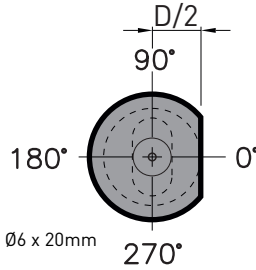

Alternate locations page 83



$G = \sqrt{P^2 + W^2}$. $G \leq \varnothing D - 0,1$

Delivered with dowel pins - Ø6 x 20mm
A20.006.020

270°

Reference	Ø D	L1				L2	ØE	P_-PPFS	Others shapes	
		71	80	100	120			ØP	W (min)	P / G (max)
<p>Shapes</p> <p>Material</p> <p>PB - P_PFR</p> <p>S L F V H</p> <p>(TMY) = E (TMX) = T (SPECIALS) = X</p>	10	B	B	B	B	13	1,3	4,5 - 9,9	4,5	9,9
	13	B	B	B	B	16	1,3	6,5 - 12,9	6	12,9
	16	B	B	B	B	20	2,2	9,5 - 15,9	7	15,9
	20	B	B	B	B	20	2,2	12,5 - 19,9	8	19,9
	25	B	B	B	B	20	2,2	16,5 - 24,9	10	24,9
	32	B	B	B	B	20	2,2	22,5 - 31,9	12	31,9
	40	B	B	B	B	20	2,2	30,5 - 39,9	14	39,9
	ØD and length "L1" : Others dimensions on request.		LU				Length L2 applied by default, others dimensions on request.			
		39	48	68	68					

Material	Body	Head
B = (Z90 WDCV 06050402)	60 - 64	47 - 57 HRc

+ Other materials on request.
Other cutting shapes (E ; T ; X) : page 81
Available coatings : page 90
Technical options : page 83

To order :	
Punch HSS 150 8020 Dowel Blank D/body L1	Blank
PB - P_PFB - 16 - 71	
Punch HSS 150 8020 Dowel Rectangle D/body L1 L2	Shaped
PB - P_PFR - 16 - 71 - 20 - P11.2 - W8.2 - R2 - T90	
Shape dimensions	Flat Position

NEW

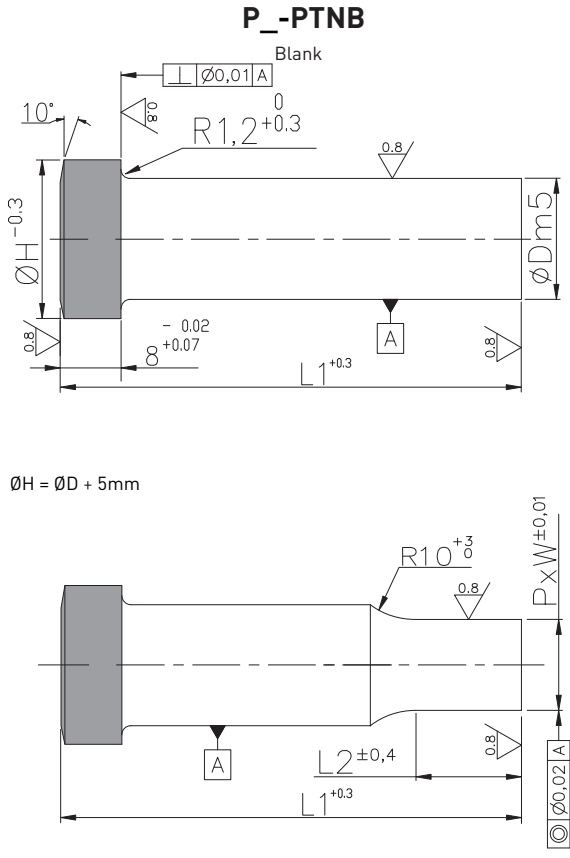

ØH = ØD + 5mm

! $G = \sqrt{P^2 + W^2}$. $G \leq \text{ØD} - 0,1$

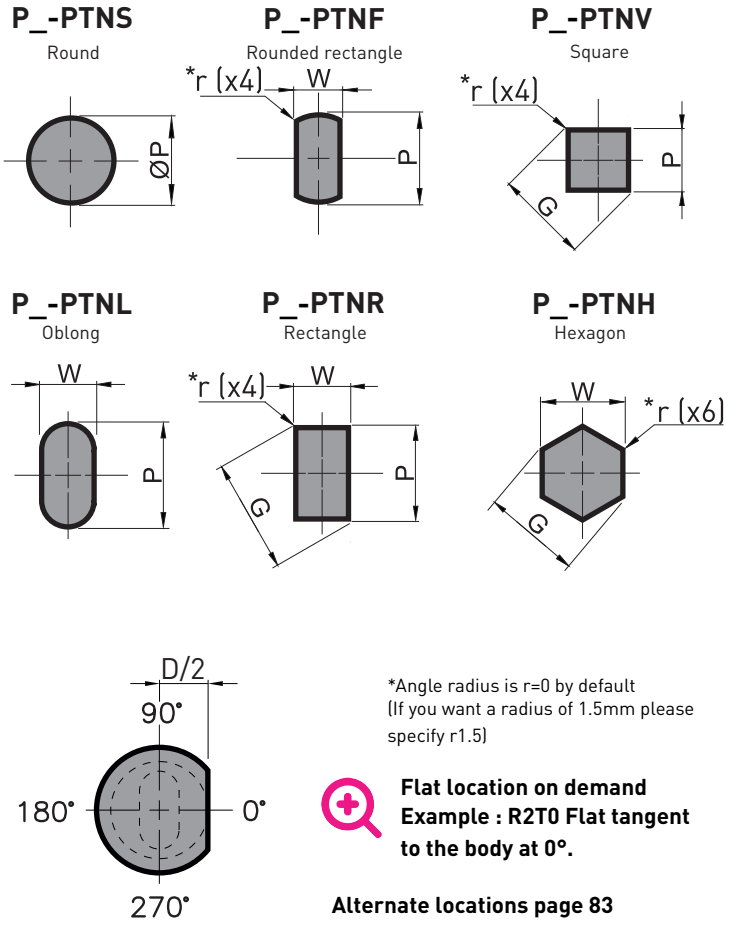

*Angle radius is r=0 by default
(If you want a radius of 1.5mm please specify r1.5)

+ Flat location on demand
Example : R2T0 Flat tangent to the body at 0°.

Alternate locations page 83

Reference	Ø D	L1			L2	P_-PTNS	Others shapes	
		71	80	100		ØP	W (min)	P / G (max)
Shapes Material P B - P T N R S (TMY) = E (TMX) = T (SPECIALS) = X	8	B+S	B+S	B+S	13	3 - 7,9	3	7,9
	10	B+S	B+S	B+S	13	4,5 - 9,9	4,5	9,9
	13	B+S	B+S	B+S	16	8 - 12,9	6	12,9
	16	B+S	B+S	B+S	20	9,5 - 15,9	6	15,9
	20	B+S	B+S	B+S	20	12,5 - 19,9	8	19,9
	25	B+S	B+S	B+S	20	18 - 24,9	10	24,9
	32	B+S	B+S	B+S	20	22,5 - 31,9	12	31,9

ØD and length "L1" : Others dimensions on request Length L2 applied by default, others dimensions on request.

Material	Body	Head
B = (Z90 WDCV 06050402)	60 - 64	47 - 57 HRc
S = (M4)	62 - 66	47 - 57 HRc

+ Other materials on request.
Other cutting shapes (E ; T ; X) : page 81
Available coatings : page 90
Technical options : page 83

To order :

Punch HSS Heavy duty Solid Blank D/body L1
P B - P T N B - 16 - 71 Blank

Punch HSS Heavy duty Solid Rectangle D/body L1 L2 Shape dimensions Flat Position
P B - P T N R - 16 - 71 - 20 - P10.2 - W7.2 - R2 - T90

NEW

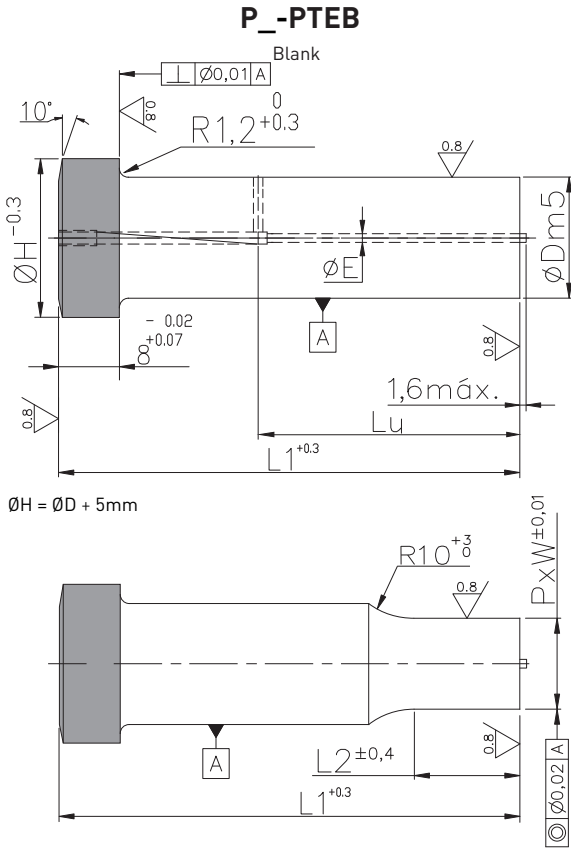

ØH = ØD + 5mm

P_-PTES
Round

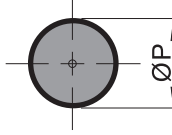

P_-PTEF
Rounded rectangle

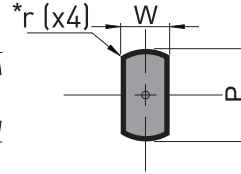

P_-PTEV
Square

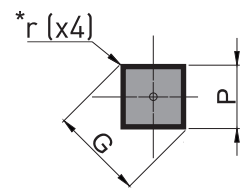

P_-PTEL
Oblong

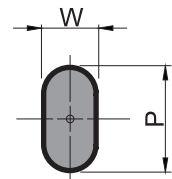

P_-PTER
Rectangle

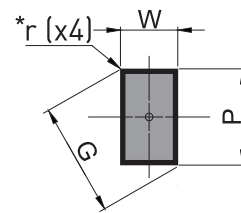

P_-PTEH
Hexagon

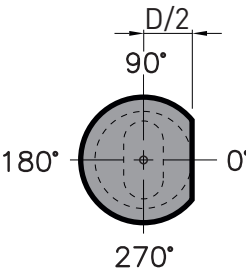
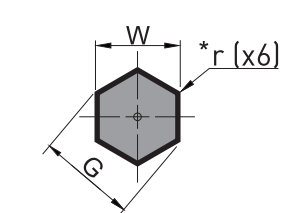

*Angle radius is r=0 by default
(If you want a radius of 1.5mm please specify r1.5)



Flat location on demand
Example : R2T0 Flat tangent to the body at 0°.

Alternate locations page 83



$$G = \sqrt{P^2 + W^2} \cdot G \leq \text{ØD} - 0,1$$

Reference	Ø D	L1			L2	ØE	P_-PTES	Others shapes	
		71	80	100			ØP	W (min)	P / G (max)
Shapes S L PB - PTER F V H S (TMY) = E (TMX) = T (SPECIALS) = X	8	B+S	B+S	B+S	13	1,1	4 - 7,9	3	7,9
	10	B+S	B+S	B+S	13	1,3	5,5 - 9,9	4,5	9,9
	13	B+S	B+S	B+S	16	1,3	8 - 12,9	6	12,9
	16	B+S	B+S	B+S	20	2,2	9,5 - 15,9	6	15,9
	20	B+S	B+S	B+S	20	2,2	12,5 - 19,9	8	19,9
	25	B+S	B+S	B+S	20	2,2	18 - 24,9	10	24,9
	32	B+S	B+S	B+S	20	2,2	22,5 - 31,9	12	31,9
ØD and length "L1" : Others dimensions on request.		LU			Length L2 applied by default, others dimensions on request.				
		39	48	68					

Material	Body	Head
B = (Z90 WDCV 06050402)	60 - 64	47 - 57 HRc
S = (M4)	62 - 66	47 - 57 HRc



Other materials on request.
Other cutting shapes (E ; T ; X) : page 81

Available coatings : page 90
Technical options : page 83

To order :

Punch HSS Heavy duty Ejector Blank D/body L1
PB - PTEB - 16 - 71

Punch HSS Heavy duty Ejector Rectangle D/body L1 L2 Shape dimensions Flat Position
PB - PTER - 16 - 71 - 20 - P9.2 - W6.2 - R2 - T90

NEW

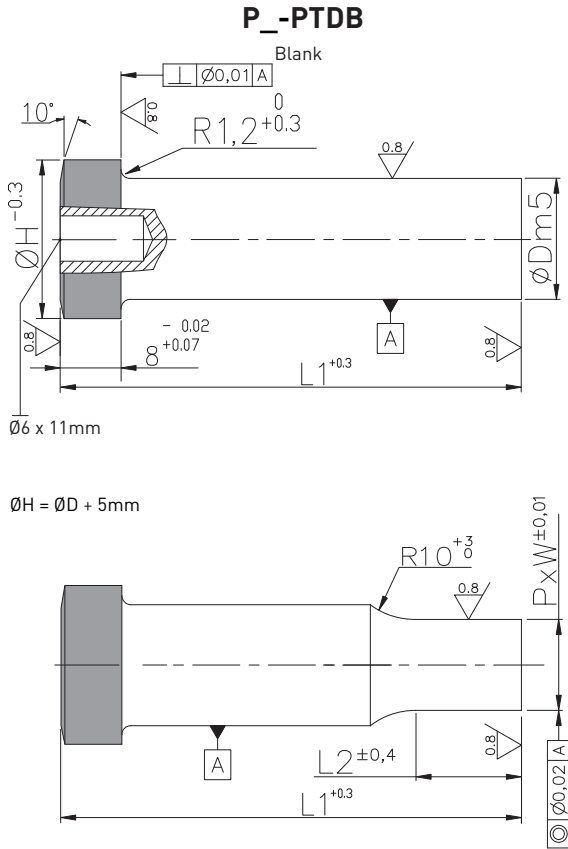

$\text{ØH} = \text{ØD} + 5\text{mm}$



$G = \sqrt{P^2 + W^2}$. $G \leq \text{ØD} - 0,1$

Delivered with dowel pins - Ø6 x 20mm
A20.006.020

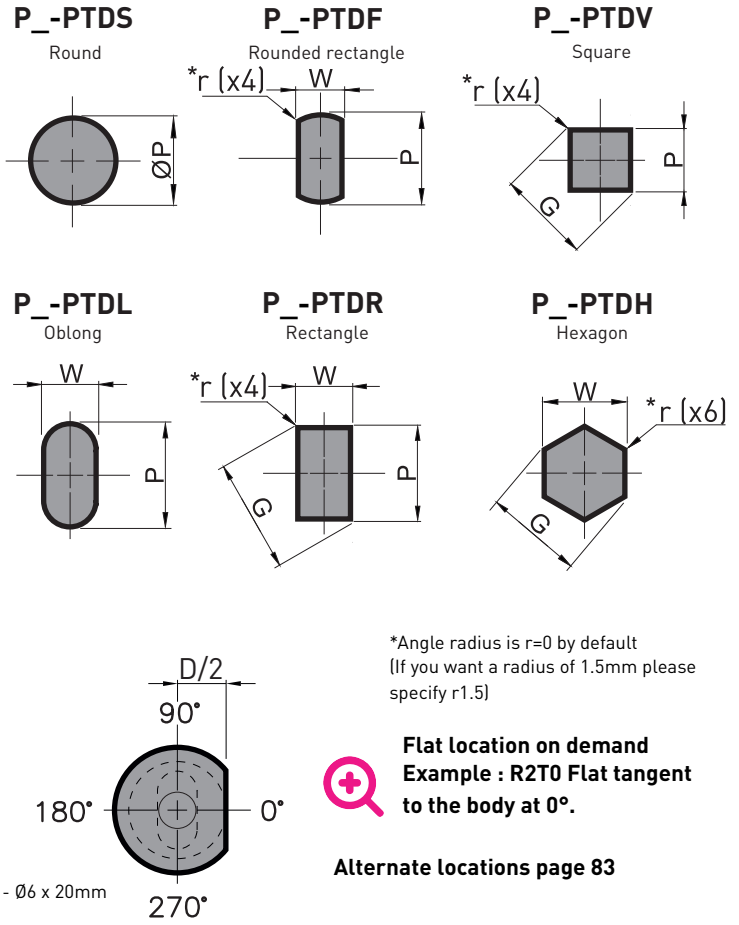

*Angle radius is $r=0$ by default
(If you want a radius of 1.5mm please specify $r1.5$)

Flat location on demand
Example : R2T0 Flat tangent to the body at 0°.



Alternate locations page 83

Reference	Ø D	L1			L2	P_-PTDS	Others shapes	
		71	80	100		ØP	W (min)	P / G (max)
Shapes Material PB - PTDR S (TMY) = E (TMX) = T (SPECIALS) = X	8	B+S	B+S	B+S	13	3 - 7,9	3	7,9
	10	B+S	B+S	B+S	13	4,5 - 9,9	4,5	9,9
	13	B+S	B+S	B+S	16	8 - 12,9	6	12,9
	16	B+S	B+S	B+S	20	9,5 - 15,9	6	15,9
	20	B+S	B+S	B+S	20	12,5 - 19,9	8	19,9
	25	B+S	B+S	B+S	20	18 - 24,9	10	24,9
	32	B+S	B+S	B+S	20	22,5 - 31,9	12	31,9

ØD and length "L1" : Others dimensions on request Length L2 applied by default, others dimensions on request.

Material	Body	Head
B = (Z90 WDCV 06050402)	60 - 64	47 - 57 HRc
S = (M4)	62 - 66	47 - 57 HRc

+ Other materials on request.
Other cutting shapes (E ; T ; X) : page 81
Available coatings : page 90
Technical options : page 83

To order :

Punch HSS Heavy duty Dowel Blank D/body L1
PB - PTDB - 16 - 71

Punch HSS Heavy duty Dowel Rectangle D/body L1 L2 Shape dimensions Flat Position
PB - PTD R - 16 - 71 - 20 - P9.2 - W6.2 - R2 - T90

NEW

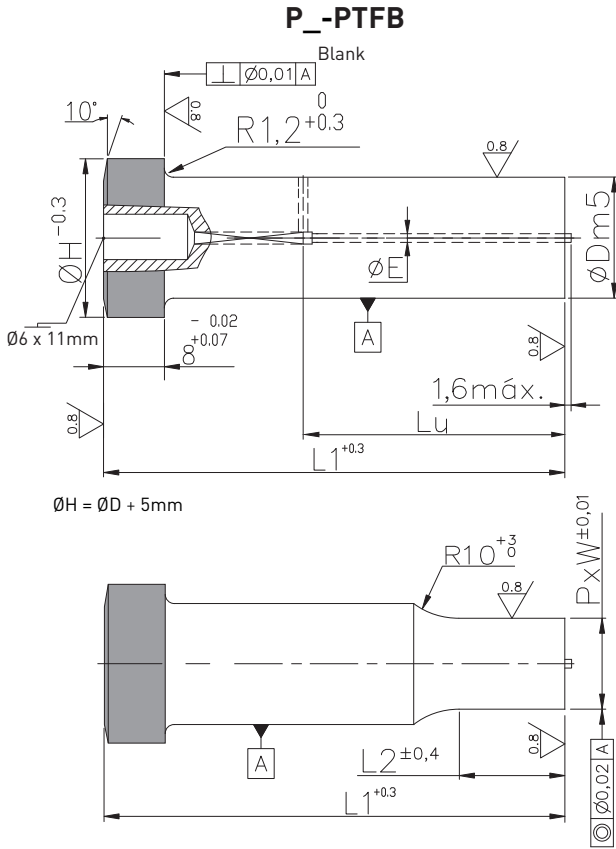

P_-PTFS
Round

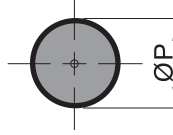

P_-PTFF
Rounded rectangle

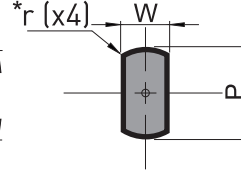

P_-PTFV
Square

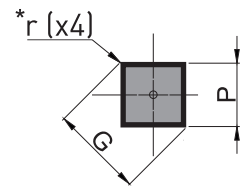

P_-PTFL
Oblong

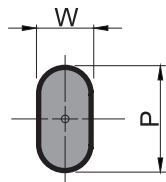

P_-PTFR
Rectangle

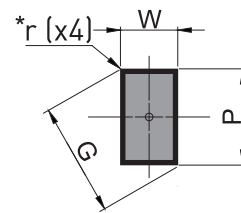

P_-PTFH
Hexagon

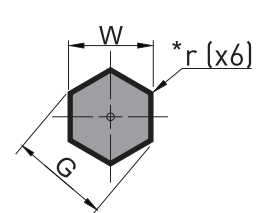

*Angle radius is r=0 by default
(If you want a radius of 1.5mm please specify r1.5)

Flat location on demand
Example : R2T0 Flat tangent to the body at 0°.



Alternate locations page 83



$$G = \sqrt{P^2 + W^2} \cdot G \leq \text{ØD} - 0,1$$

Delivered with dowel pins - Ø6 x 20mm
A20.006.020

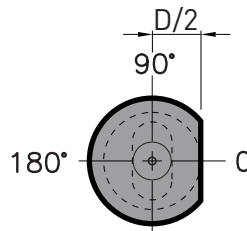

270°

Reference	Ø D	L1			L2	ØE	P_-PTFS	Others shapes	
		71	80	100			ØP	W (min)	P / G (max)
Shapes Material PB - PTFR S (TMY) = E (TMX) = T (SPECIALS) = X	8	B+S	B+S	B+S	13	1,1	4 - 7,9	3	7,9
	10	B+S	B+S	B+S	13	1,3	5,5 - 9,9	4,5	9,9
	13	B+S	B+S	B+S	16	1,3	8 - 12,9	6	12,9
	16	B+S	B+S	B+S	20	2,2	9,5 - 15,9	6	15,9
	20	B+S	B+S	B+S	20	2,2	12,5 - 19,9	8	19,9
	25	B+S	B+S	B+S	20	2,2	18 - 24,9	10	24,9
	32	B+S	B+S	B+S	20	2,2	22,5 - 31,9	12	31,9
ØD and length "L1" : Others dimensions on request.		LU			Length L2 applied by default, others dimensions on request.				
		39	48	68					

Material	Body	Head
B = (Z90 WDCV 06050402)	60 - 64	47 - 57 HRc
S = (M4)	62 - 66	47 - 57 HRc

+ Other materials on request.
Other cutting shapes (E ; T ; X) : page 81
Available coatings : page 90
Technical options : page 83

To order :	
Punch HSS	Blank
Heavy duty Dowel Ejector Blank	D/body L1
PB - PTFB - 16 - 71	
Punch HSS	Shaped Position
Heavy duty Dowel Ejector Rectangle	D/body L1 L2
PB - PTFR - 16 - 71 - 20 - P10.2 - W8.2 - R2 - T90	

NEW

PB-PANB

Blank

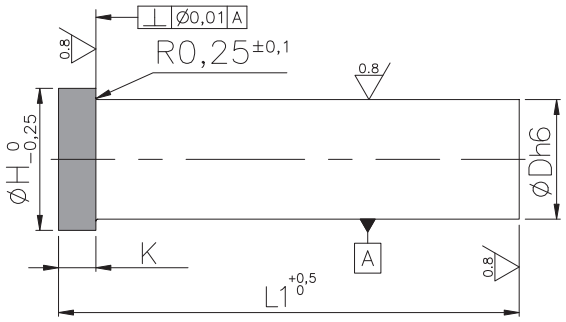

$\varnothing H = \varnothing D + 3\text{mm}$

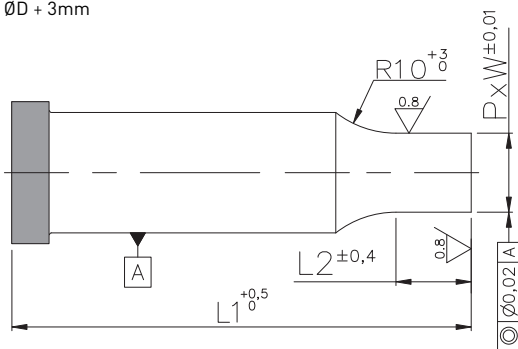

$G = \sqrt{P^2 + W^2} \cdot G \leq \varnothing D - 0,1$

PB-PANS

Round

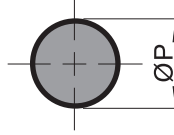

PB-PANF

Rounded rectangle

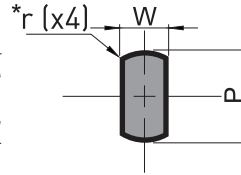

PB-PANV

Square

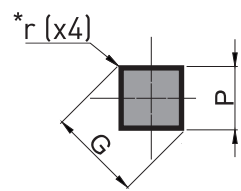

PB-PANL

Oblong

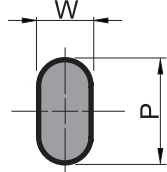

PB-PANR

Rectangle

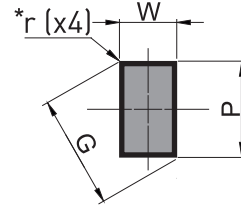

PB-PANH

Hexagone

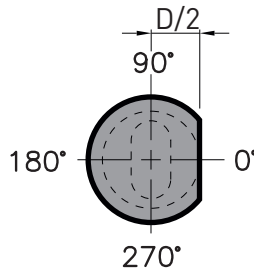
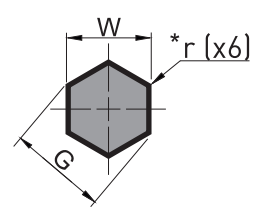

*Angle radius is $r=0$ by default
(If you want a radius of 1.5mm please specify $r1.5$)



Flat location on demand
Example : R2T0 Flat tangent to the body at 0°.

Alternate locations page 83

Reference	$\varnothing D$	L1			L2	PB-PANS		Others shapes		$\varnothing H$	K
		71	80	100		$\varnothing P$	W (min)	P / G (max)			
<p>Shapes</p> <p>Material</p> <p>PB-PANR</p> <p>(TMY) = E (TMX) = T (SPECIALS) = X</p>	4	B	B	B	10	1,0 - 3,9	1,5	3,9	6	4	
	4,5	B	B	B	10	1,2 - 4,4	1,5	4,4	7		
	5	B	B	B	10	1,0 - 4,9	1,5	4,9	8		
	5,5	B	B	B	10	1,2 - 5,4	1,5	5,4	9		
	6	B	B	B	10	1,5 - 5,9	1,5	5,9	9		
	6,5	B	B	B	10	1,7 - 6,4	1,6	6,4	10		
	7	B	B	B	10	2,0 - 6,9	1,7	6,9	10		
	7,5	B	B	B	13	2,1 - 7,4	1,9	7,4	11		
	8	B	B	B	13	2,5 - 7,9	2	7,9	11		
	8,5	B	B	B	13	3 - 8,4	2,4	8,4	12		
	9	B	B	B	13	3,5 - 8,9	2,7	8,9	12		
	10	B	B	B	13	4,5 - 9,9	3,5	9,9	13		
	11	B	B	B	13	5,1 - 10,9	3,8	10,9	14		
	12	B	B	B	16	5,8 - 11,9	4,2	11,9	15		
	13	B	B	B	16	6,5 - 12,9	4,5	12,9	16		
	14	B	B	B	16	7,5 - 13,9	5,1	13,9	17		
15	B	B	B	20	8,5 - 14,9	5,7	14,9	18			
16	B	B	B	20	9,5 - 15,9	6	15,9	19	5		

$\varnothing D$ and length "L1" : Others dimensions on request.

Length L2 applied by default, others dimensions on request.

Material	Body	Head
B = (Z90 WDCV 06050402)	60 - 64	47 - 57 HRc

To order :

Blank

Punch HSS DIN 9844 Solid Blank D.body L1
PB-PANB-10-71

Punch HSS DIN 9844 Solid Rectangle D.body L1 L2 Shape dimensions Flat Position
PB-PANR-10-71-20-P6.2-W4.2-R2-T90



Other materials on request.
Other cutting shapes (E ; T ; X) : page 81
Available coatings : page 90
Technical options : page 83

P_-PSNB
Blank

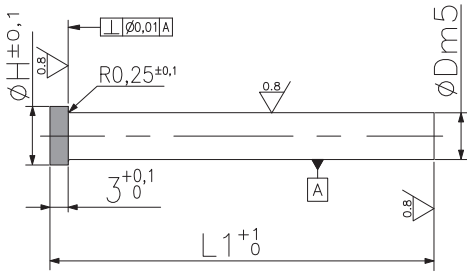

$\varnothing H = \varnothing D + 1,5\text{mm}$

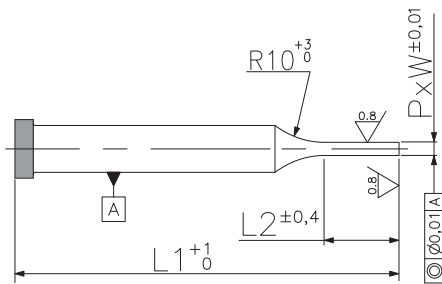

! $G = \sqrt{P^2 + W^2}$. $G \leq \varnothing D - 0,1$

P_-PSNS
Round

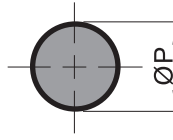

P_-PSNF
Rounded rectangle

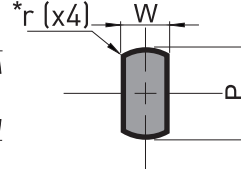

P_-PSNV
Square

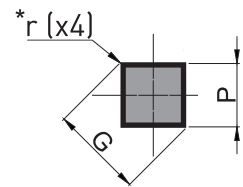

P_-PSNL
Oblong

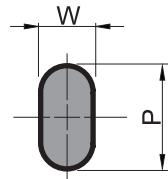

P_-PSNR
Rectangle

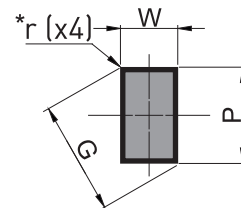

P_-PSNH
Hexagon

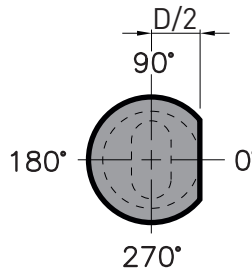
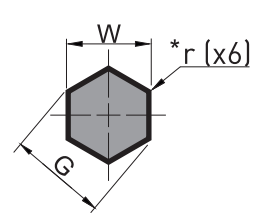

*Angle radius is r=0 by default
(If you want a radius of 1.5mm please specify r1.5)



Flat location on demand
Example : R2T0 Flat tangent to the body at 0°.

Alternate locations page 83

Reference	Ø D	L1			L2	P_-PSNS	Others shapes	
		71	80	100		ØP	W (min)	P / G (max)
<div style="display: flex; flex-direction: column; align-items: center;"> <div style="margin-bottom: 10px;">Shapes</div> <div style="display: flex; align-items: center;"> <div style="border: 1px solid black; padding: 2px; margin-right: 5px;">Material</div> <div style="display: flex; flex-direction: column; gap: 5px;"> <div style="border: 1px solid black; padding: 2px;">S</div> <div style="border: 1px solid black; padding: 2px;">L</div> <div style="border: 1px solid black; padding: 2px; background-color: #cccccc;">PB - PSNR</div> <div style="border: 1px solid black; padding: 2px;">F</div> <div style="border: 1px solid black; padding: 2px;">V</div> <div style="border: 1px solid black; padding: 2px;">H</div> </div> </div> <div style="margin-top: 10px;"> (TMY) = E (TMX) = T (SPECIALS) = X </div> </div>	2	A+B	A+B	A+B	10	0,7 - 1,95	0,7	1,95
	3	A+B	A+B	A+B	13	1,6 - 2,95	0,7	2,95
	4	A+B	A+B	A+B	16	2 - 3,95	1	3,95
	5	A+B	A+B	A+B	20	2 - 4,95	1	4,95
	6	A+B	A+B	A+B	20	3 - 5,95	1,5	5,95
	ØD and length "L1" : Others dimensions on request					Length L2 applied by default, others dimensions on request.		

Material	Body	Head
A = (X155CrVMo.12.1)	58 - 62	40 - 50 HRc
B = (Z90 WDCV 06050402)	60 - 64	47 - 57 HRc

+ Other materials on request.
Other cutting shapes (E ; T ; X) : page 81
Available coatings : page 90
Technical options : page 83

To order :

Punch HSS Micro Solid Blank D.body L1 L2
PB - PSNB - 6 - 71 Blank

Punch HSS Micro Solid Rectangle D.body L1 L2 Shape dimensions Flat Position
PB - PSNR - 6 - 71 - 20 - P5.2 - W3.2 - R2 - T90 Shaped

Straight pilots

Reference	Ø D	L1	L2
Material PB - PPNP	8	25	14
	8	30	19
	10	25	14
	10	30	19
	12	25	14
	12	30	19

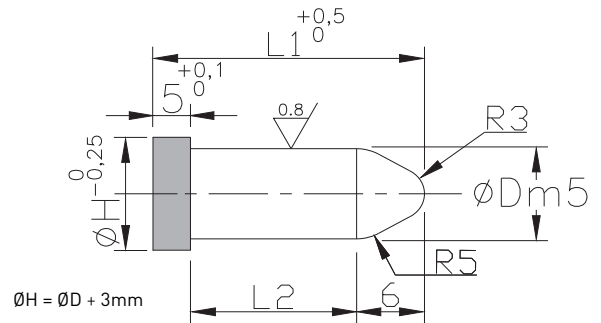

To order :

Punch HSS Heated Solid Pilot D.body L1
PB - PPNP - 12 - 30

Standard pilots

! LV = L1 + 6,5

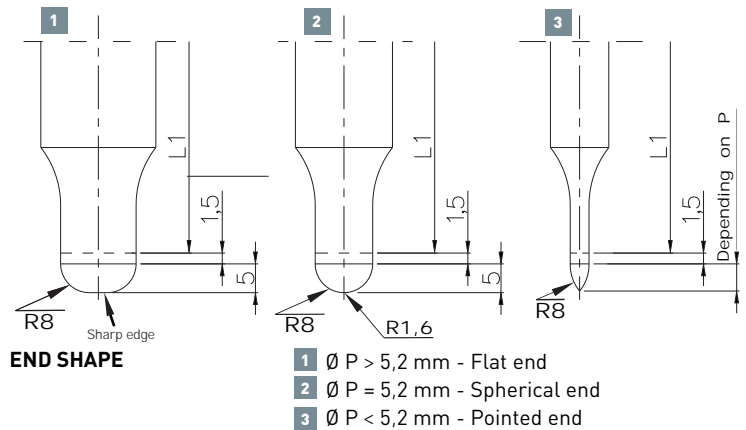
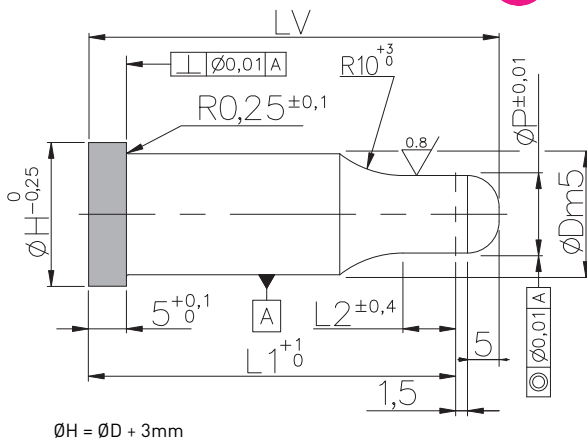

END SHAPE

- 1 Ø P > 5,2 mm - Flat end
- 2 Ø P = 5,2 mm - Spherical end
- 3 Ø P < 5,2 mm - Pointed end

Reference	Ø D	L1				L2	Ø P
		71	80	90	110		
Material PB - PPNZ A	5	B	B	B	B	13	0,8 - 4,9
	6	B	B	B	B	13	1,5 - 5,9
	8	B	B	B	B	16	2,5 - 7,9
	10	A+B	A+B	A+B	B	16	4,5 - 9,9
	13	A+B	A+B	A+B	B	16	6,5 - 12,9
	16	A+B	A+B	A+B	B	20	9,5 - 15,9
	20	A+B	A+B	A+B	B	20	12,5 - 19,9
	25	A+B	A+B	A+B	B	20	16,5 - 24,9

ØD and length "L1" : Others dimensions on request. Length L2 applied by default, others dimensions on request.

Material	Body	Head
A = (X155CrVMo.12.1)	58 - 62	40 - 50 HRc
B = (Z90 WDCV 06050402)	60 - 64	47 - 57 HRc

To order :

Punch HSS Heated Solid Pilot D.body L1 L2 Dimensions
PB - PPNZ - 16 - 71 - 20 - P12.5

+ Other materials on request.

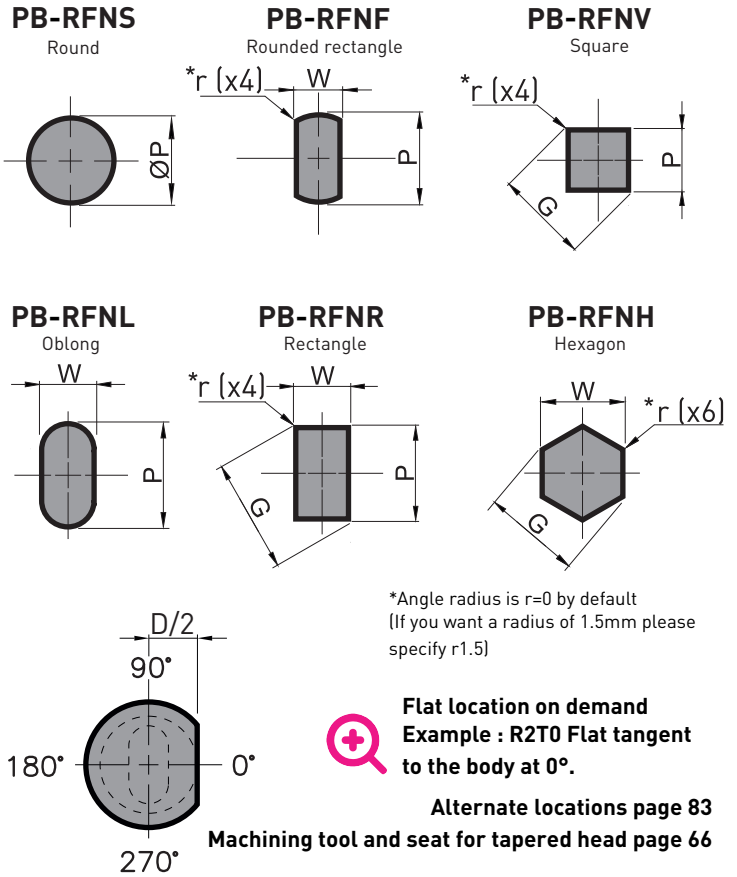
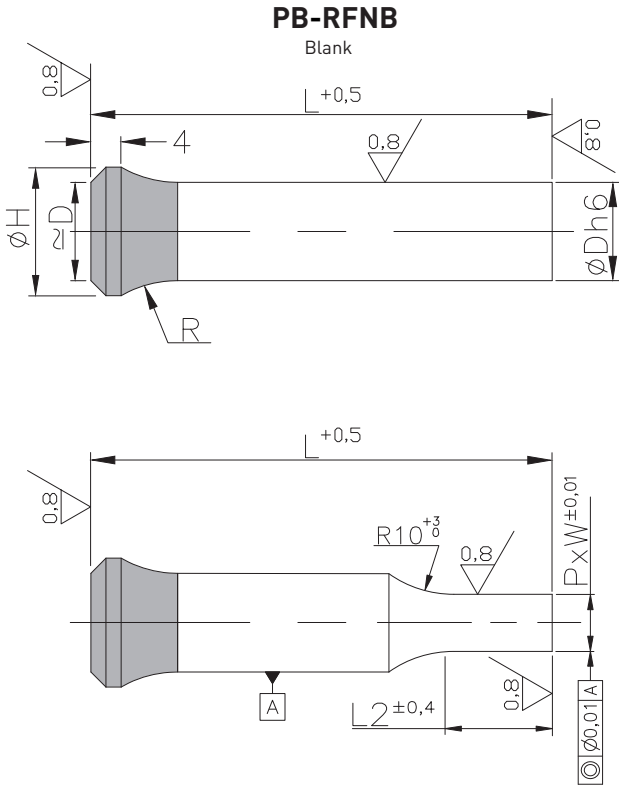

! $G = \sqrt{P^2 + W^2}$. $G \leq \text{ØD} - 0,1$

Reference	Ø D	L1				L2	PB-RFNS			Others shapes		Ø H	R
		71	80	100	120		ØP	W (min)	P / G (max)				
	5	B	B	B	B	10	1,0 - 4,9	1,5	4,9	7	10		
	5,5	B	B	B	B	10	1,2 - 5,4	1,5	5,4	8	10		
	6	B	B	B	B	10	1,5 - 5,9	1,5	5,9	9	10		
	6,5	B	B	B	B	10	1,7 - 6,4	1,6	6,4	9,5	12		
	7	B	B	B	B	10	2,0 - 6,9	1,7	6,9	10	12		
	7,5	B	B	B	B	13	2,1 - 7,4	1,9	7,4	11	12		
	8	B	B	B	B	13	2,5 - 7,9	2	7,9	11	12		
	8,5	B	B	B	B	13	3,0 - 8,4	2,4	8,4	13	15		
	9	B	B	B	B	13	3,5 - 8,9	2,7	8,9	13	15		
	9,5	B	B	B	B	13	4,0 - 9,4	3,1	9,4	14	15		
	10	B	B	B	B	13	4,5 - 9,9	3,5	9,9	14	15		
	10,5	B	B	B	B	13	4,9 - 10,4	3,7	10,4	15	15		
	11	B	B	B	B	13	5,1 - 10,9	3,8	10,9	15	15		
	11,5	B	B	B	B	16	5,7 - 11,4	4	11,4	16	15		
	12	B	B	B	B	16	5,8 - 11,9	4,2	11,9	16	15		
	13	B	B	B	B	16	6,5 - 12,9	4,5	12,9	17	15		
	14	B	B	B	B	16	7,5 - 13,9	5,1	13,9	18	15		
	15	B	B	B	B	20	8,5 - 14,9	5,7	14,9	19	15		
	16	B	B	B	B	20	9,5 - 15,9	6	15,9	20	15		
	17	B	B	B	B	20	9,5 - 16,9	6,5	16,9	21	15		
	18	B	B	B	B	20	10,5 - 17,9	7	17,9	22	15		
	19	B	B	B	B	20	10,5 - 18,9	7,5	18,9	23	15		
	20	B	B	B	B	20	12,5 - 19,9	8	19,9	25	15		
	25	B	B	B	B	20	16,5 - 24,9	10	24,9	30	15		

ØD and length "L1" : Others dimensions on request. Length L2 applied by default, others dimensions on request.

Material	Body	Head
B = (Z90 WDCV 06050402)	60 - 64	47 - 57 HRc

To order :

Punch HSS Tapered Solid Blank D.body L1 L2 Shaped Position

PB-RFNB-16-71

PB-RFNR-16-71-20-P10.2-W7.2-R2-T90

+ Other materials on request.
Other cutting shapes (E ; T ; X) : page 81
Available coatings : page 90
Technical options : page 83

NEW

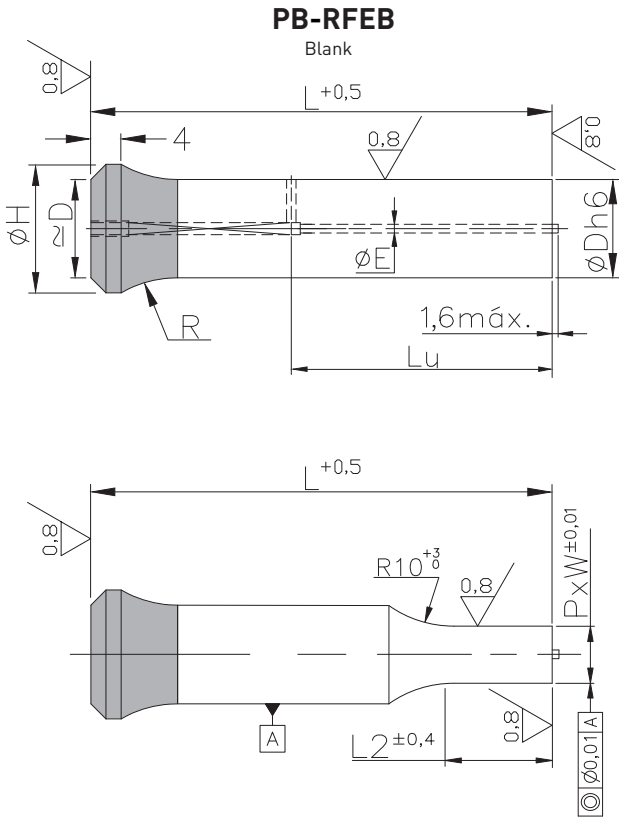

PB-RFES
Round

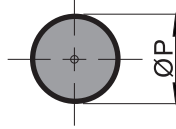

PB-RFEF
Rounded rectangle

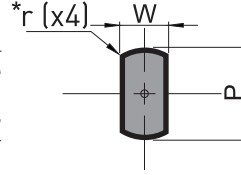

PB-RFEV
Square

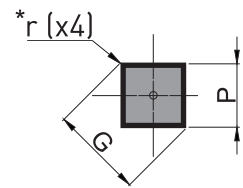

PB-RFEL
Oblong

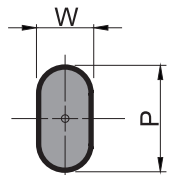

PB-RFER
Rectangle

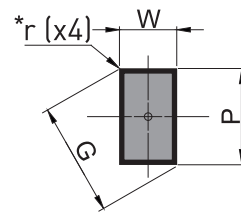

PB-RFEH
Hexagon

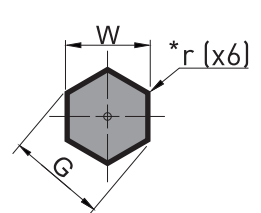

*Angle radius is r=0 by default
(If you want a radius of 1.5mm please specify r1.5)

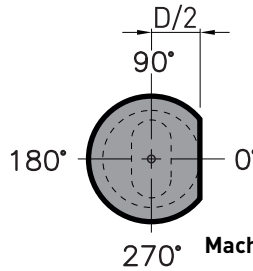

Flat location on demand
Example : R2T0 Flat tangent to the body at 0°.

Alternate locations page 83

Machining tool and seat for tapered head page 66

! $G = \sqrt{P^2 + W^2} . G \leq \text{ØD} - 0,1$

Reference	Ø D	L1			L2	ØE	PB-RFES	Others shapes		Ø H	R
		71	80	100			ØP	W (min)	P / G (max)		
PB - RFER Shapes: S, L, F, V, H Material: (TMY) = E, (TMX) = T, (SPECIALS) = X	8	B	B	B	13	1,1	2,5 - 7,9	3	7,9	11	12
	10	B	B	B	13	1,3	4,5 - 9,9	4,5	9,9	14	15
	13	B	B	B	16	2,2	6,5 - 12,9	6	12,9	17	15
	16	B	B	B	20	2,2	9,5 - 15,9	7	15,9	20	15
	20	B	B	B	20	2,2	12,5 - 19,9	8	19,9	25	15
	25	B	B	B	20	2,2	16,5 - 24,9	10	24,9	30	15
ØD and length "L1" : Others dimensions on request.		LU			Length L2 applied by default, others dimensions on request.						
		39	48	68							

Material	Body	Head
B = (Z90 WDCV 06050402)	60 - 64	47 - 57 HRc

+ Other materials on request.
Other cutting shapes (E ; T ; X) : page 81
Available coatings : page 90
Technical options : page 83

To order :

Punch H2S	Tapered Solid	Blank	D.body	L1	L2	Shape dimensions	Flat	Shaped Position
PB - RFEB - 16 - 71								
Punch H2S	Tapered Solid	Oblong	D.body	L1	L2	Shape dimensions	Flat	Shaped Position
PB - RFEL - 16 - 71 - 20 - P10.2 - W7.2 - R2 - T0								

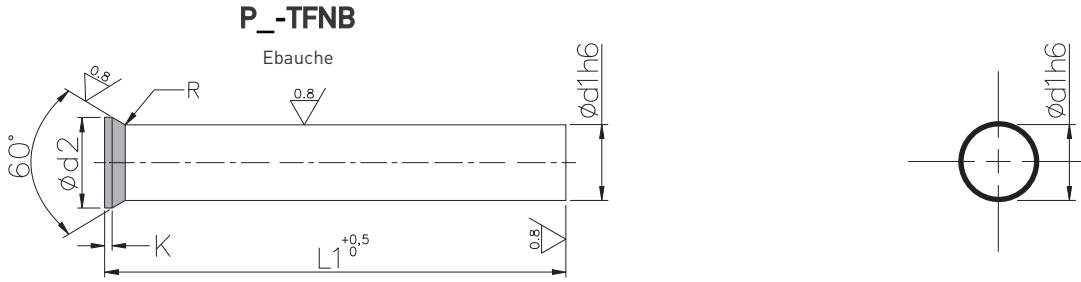

Reference	Ø d1	Ø d2	K	L1		Ø d1	Ø d2	K	L1		Ø d1	Ø d2	K	L1	
				71	100				71	100				71	100
	0,5	0,9	0,2	A+B	A	5,8	7	0,5	A+B	A+B	11,1	13	1	A	A
	0,6	1,1		A+B	A	5,9			A+B	A+B	11,2			A	A
	0,7	1,3		A+B	A	6			A+B	A+B	11,3			A	A
	0,8	1,4	0,4	A+B	A	6,1	8	0,5	A+B	A+B	11,4	14	1	A	A
	0,9	1,6		A+B	A	6,2			A+B	A+B	11,5			A+B	A+B
	1	1,8		A+B	A+B	6,3			A+B	A+B	11,6			A	A
	1,1	2	0,5	A+B	A+B	6,4	9	1	A+B	A+B	11,7	15	1,5	A	A
	1,2			A+B	A+B	6,5			A+B	A+B	11,8			A	A
	1,3			A+B	A+B	6,6			A+B	A+B	11,9			A	A
	1,4	2,2	0,5	A+B	A+B	6,7	10	1	A+B	A+B	12	16	1,5	A+B	A+B
	1,5			A+B	A+B	6,8			A+B	A+B	12,1			A	A
	1,6			A+B	A+B	6,9			A+B	A+B	12,2			A	A
	1,7	2,5	0,5	A+B	A+B	7	11	1	A+B	A+B	12,3	17	1,5	A	A
	1,8			A+B	A+B	7,1			A+B	A+B	12,4			A	A
	1,9			A+B	A+B	7,2			A+B	A+B	12,5			A+B	A+B
	2	3	0,5	A+B	A+B	7,3	12	1	A+B	A+B	12,6	18	1,5	A	A
	2,1			A+B	A+B	7,4			A+B	A+B	12,7			A	A
	2,2			A+B	A+B	7,5			A+B	A+B	12,8			A	A
	2,3	3,2	0,5	A+B	A+B	7,6	13	1	A+B	A+B	12,9	19	1,5	A	A
	2,4			A+B	A+B	7,7			A+B	A+B	13			A+B	A+B
	2,5			A+B	A+B	7,8			A+B	A+B	13,1			A	A
	2,6	4	0,5	A+B	A+B	7,9	14	1	A+B	A+B	13,2	20	1,5	A	A
	2,7			A+B	A+B	8			A+B	A+B	13,3			A	A
	2,8			A+B	A+B	8,1			A+B	A+B	13,4			A	A
	2,9	4,5	0,5	A+B	A+B	8,2	15	1	A+B	A+B	13,5	21	1,5	A+B	A+B
	3			A+B	A+B	8,3			A+B	A+B	13,6			A	A
	3,1			A+B	A+B	8,4			A+B	A+B	13,7			A	A
	3,2	5	0,5	A+B	A+B	8,5	16	1	A+B	A+B	13,8	22	1,5	A	A
	3,3			A+B	A+B	8,6			A+B	A+B	13,9			A	A
	3,4			A+B	A+B	8,7			A+B	A+B	14			A+B	A+B
	3,5	5,5	0,5	A+B	A+B	8,8	17	1	A+B	A+B	14,1	23	1,5	A	A
	3,6			A+B	A+B	8,9			A+B	A+B	14,2			A	A
	3,7			A+B	A+B	9			A+B	A+B	14,3			A	A
	3,8	6	0,5	A+B	A+B	9,1	18	1	A+B	A+B	14,4	24	1,5	A	A
	3,9			A+B	A+B	9,2			A+B	A+B	14,5			A+B	A+B
	4			A+B	A+B	9,3			A+B	A+B	14,6			A	A
	4,1	6,5	0,5	A+B	A+B	9,4	19	1	A+B	A+B	14,7	25	1,5	A	A
	4,2			A+B	A+B	9,5			A+B	A+B	14,8			A	A
	4,3			A+B	A+B	9,6			A+B	A+B	14,9			A	A
	4,4	7	0,5	A+B	A+B	9,7	20	1	A+B	A+B	15	26	1,5	A+B	A+B
	4,5			A+B	A+B	9,8			A+B	A+B	15,1			A	A
	4,6			A+B	A+B	9,9			A+B	A+B	15,2			A	A
	4,7	7,5	0,5	A+B	A+B	10	21	1	A+B	A+B	15,3	27	1,5	A	A
	4,8			A+B	A+B	10,1			A	A	15,4			A	A
	4,9			A+B	A+B	10,2			A	A	15,5			A+B	A+B
	5	8	0,5	A+B	A+B	10,3	22	1	A	A	15,6	28	1,5	A	A
	5,1			A+B	A+B	10,4			A	A	15,7			A	A
	5,2			A+B	A+B	10,5			A+B	A+B	15,8			A	A
	5,3	8,5	0,5	A+B	A+B	10,6	23	1	A	A	15,9	29	1,5	A	A
	5,4			A+B	A+B	10,7			A	A	16			A+B	A+B
	5,5			A+B	A+B	10,8			A	A					
	5,6	9	0,5	A+B	A+B	10,9	24	1	A	A		30	1,5		
	5,7			A+B	A+B	11			A+B	A+B					

ØD and length "L1" : Others dimensions on request.

Material	Body	Head
A = (X155CrVMo.12.1)	58 - 62	40 - 50 HRc
B = (Z90 WDCV 06050402)	60 - 64	47 - 57 HRc

To order :

Punch HSS Conical head 60° Solid Blank D.body L1
P B - T F N B - 3.4 - 100 Blank

Other materials on request

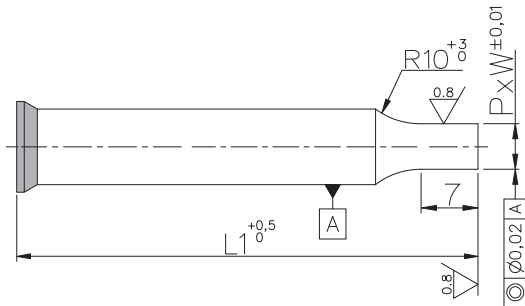

P_-TFNS
Round

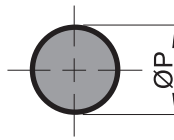

P_-TFNF
Rounded rectangle

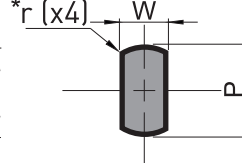

P_-TFNV
Square

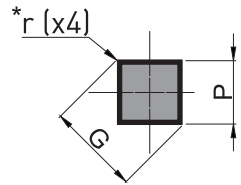

P_-TFNL
Oblong

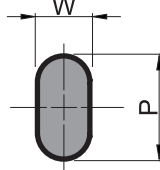

P_-TFNR
Rectangle

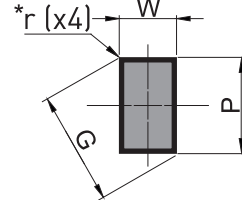

P_-TFNH
Hexagon

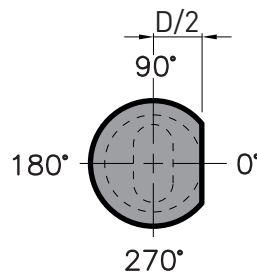
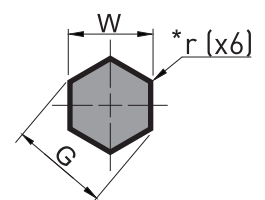

*Angle radius is r=0 by default
(If you want a radius of 1.5mm please specify r1.5)



Flat location on demand
Example : R2T0 Flat tangent to the body at 0°.

Alternate locations page 83

! $G = \sqrt{P^2 + W^2}$. $G \leq \text{ØD} - 0,1$

Reference	Ø d1	L1		P_-TFNS	Others shapes		Ø d2	K
		71	80	ØP	W (min)	P / G (max)		
	2	A+B	A+B	0,7 - 1,9	0,7	1,9	3	0,5
	3	A+B	A+B	1,0 - 2,9	1	2,9	4,5	0,5
	4	A+B	A+B	1,0 - 3,9	1,5	3,9	5,5	0,5
	5	A+B	A+B	1,0 - 4,9	1,5	4,9	6,5	0,5
	6	A+B	A+B	1,5 - 5,9	1,5	5,9	8	0,5
	7	A+B	A+B	2,0 - 6,9	1,7	6,9	9	1
	8	A+B	A+B	2,5 - 7,9	2	7,9	10	1
	9	A+B	A+B	3,5 - 8,9	2,7	8,9	11	1
	10	A+B	A+B	4,5 - 9,9	3,5	9,9	12	1
	11	A+B	A+B	5,1 - 10,9	3,8	10,9	13	1
	12	A+B	A+B	5,8 - 11,9	4,2	11,9	14	1
	13	A+B	A+B	6,5 - 12,9	4,5	12,9	15	1
	14	A+B	A+B	7,5 - 13,9	5,1	13,9	16	1,5
	15	A+B	A+B	8,5 - 14,9	5,7	14,9	17	1,5
	16	A+B	A+B	9,5 - 15,9	6	15,9	18	1,5

ØD and length "L1" : Others dimensions on request. Length L2 applied by default is 7mm, others dimensions on request.

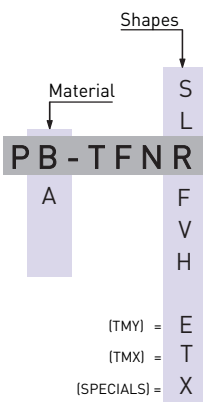

Material	Body	Head
A = (X155CrVMo.12.1)	58 - 62	40 - 50 HRc
B = (Z90 WDCV 06050402)	60 - 64	47 - 57 HRc

To order :

Punch	HSS	Conical head tip	Solid	Oblong	D body	L1	L2	Shape dimensions	Flat	Position	Shaped	
P	B	T	F	N	L	- 10	- 71	- 7	- P9	- W5	- R2	- T0

+ Other materials on request.
Other cutting shapes (E ; T ; X) : page 81
Available coatings : page 90
Technical options : page 83

NEW

PB-TFEB

Blank

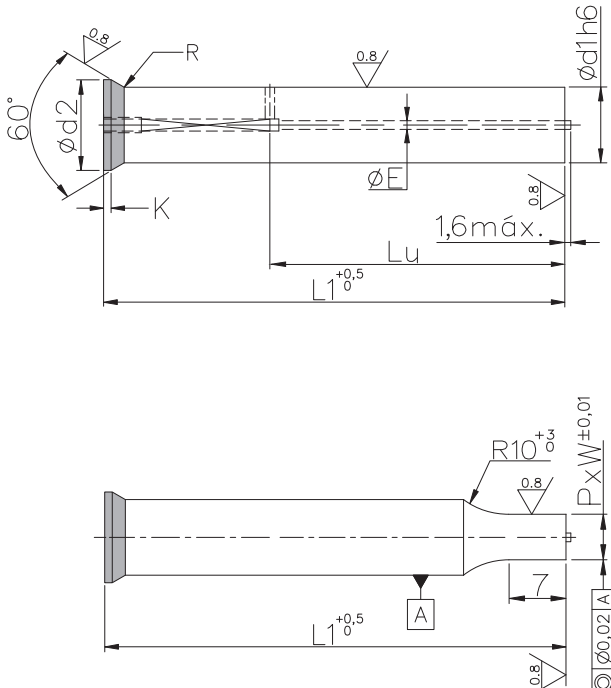

! $G = \sqrt{P^2 + W^2} \cdot G \leq \text{ØD} - 0,1$

PB-TFES

Round

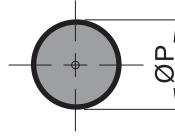

PB-TFEF

Rounded rectangle

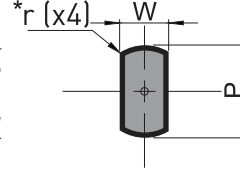

PB-TFEV

Square

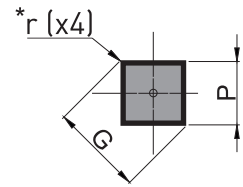

PB-TFEL

Oblong

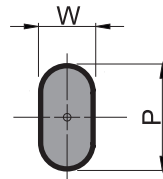

PB-TFER

Rectangle

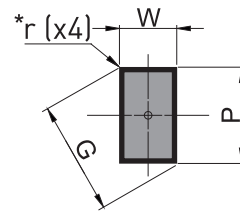

PB-TFEH

Hexagon

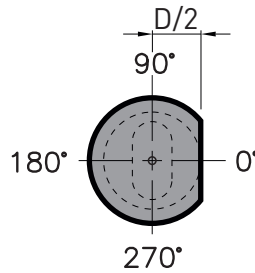
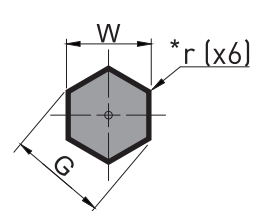

*Angle radius is r=0 by default
(If you want a radius of 1.5mm please specify r1.5)



Flat location on demand
Example : R2T0 Flat tangent to the body at 0°.

Alternate locations page 83

Reference	Ø D	L1		P_TFES	Others shapes		ØE	Ød2	K
		71	100	ØP	W (min)	P / G (max)			
Shapes S L PB-TFER F V H (TMY) = E (TMX) = T (SPECIALS) = X	8	B	B	3 - 7,9	3	7,9	1,1	10	1
	10	B	B	4,5 - 9,9	4,5	9,9	1,3	12	1
	12	B	B	5,8 - 11,9	5,8	11,9	1,3	14	1
	14	B	B	7,5 - 13,9	6	13,9	1,3	16	1,5
	16	B	B	9,5 - 15,9	7	15,9	2,2	18	1,5
ØD and length "L1" : Others dimensions on request.		LU		Length L2 applied by default is 7mm, others dimensions on request.					
		39	68						

Material	Body	Head
B = (Z90 WDCV 06050402)	60 - 64	47 - 57 HRc

+ Other materials on request.
Other cutting shapes (E ; T ; X) : page 81
Available coatings : page 90
Technical options : page 83

To order :									
Punch HSS	Conical head 60°	Ejector	Blank	D.body	L1	Blank			
PB-TFEB-10-71									
Punch HSS	Conical head 60°	Ejector	Oblong	D.body	L1	L2	Shape dimensions	Flat	Position
PB-TFEL-10-71-7-P7-W5-R2-T0									

NEW

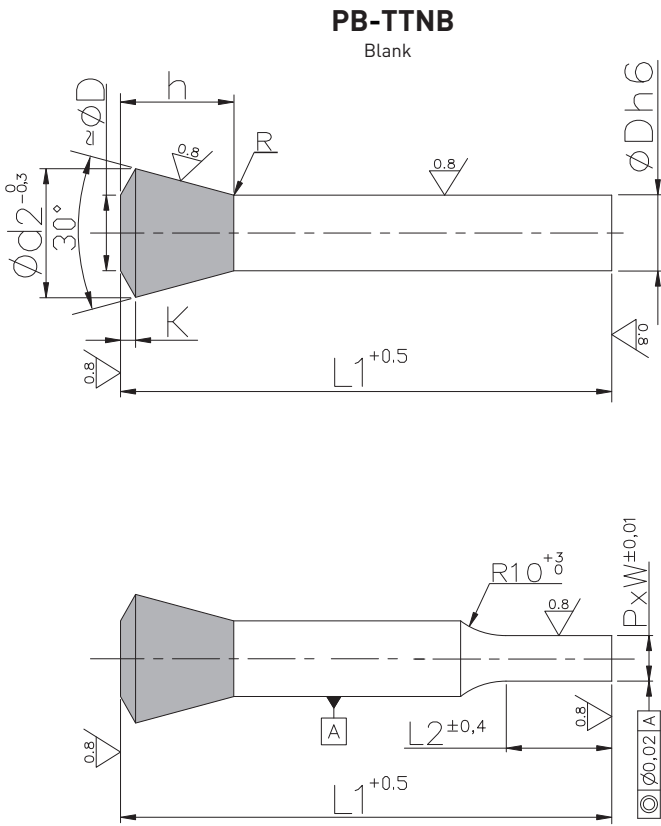

PB-TTNS
Round

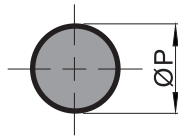

PB-TTNF
Rounded rectangle

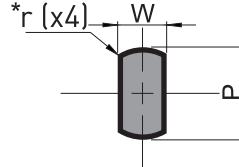

PB-TTNV
Square

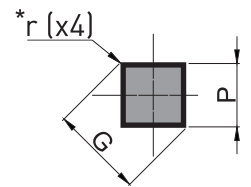

PB-TTNL
Oblong

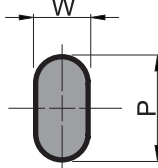

PB-TTNR
Rectangle

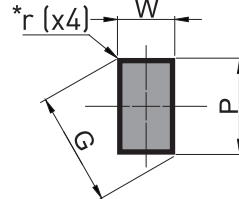

PB-TTNH
Hexagon

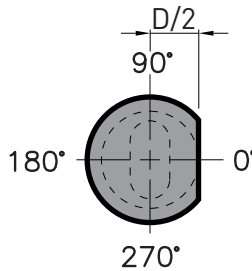
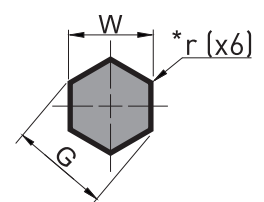

*Angle radius is r=0 by default
(If you want a radius of 1.5mm please specify r1.5)

Flat location on demand
Example : R2T0 Flat tangent to the body at 0°.



Alternate locations page 83



$$G = \sqrt{P^2 + W^2} \cdot G \leq \text{ØD} - 0,1$$

Reference	Ø D	L1		L2	PB-TTNS	Others shapes		Ød2	K	h
		ØP	W (min)		P / G (max)					
Shapes S L PB-TTNR F V H [TMY] = E [TMX] = T [SPECIALS] = X	6	B	B	13	1,5 - 5,9	1,5	5,9	10	1	8
	8	B	B	13	2,5 - 7,9	2	7,9	13	1	10
	9	B	B	20	3,5 - 8,9	2,7	8,9	14,5	1	11
	10	B	B	20	4,5 - 9,9	3,5	9,9	16	1	12
	12		B	20	5,8 - 11,9	4,2	11,9	19	1,5	14
	14		B	20	7,5 - 13,9	5,1	13,9	22	1,5	16
	16		B	20	9,5 - 15,9	6	15,9	24,7	1,5	18
ØD and length "L1" : Others dimensions on request					Length L2 applied by default, others dimensions on request.					

Material	Body	Head
B = (Z90 WDCV 06050402)	60 - 64	47 - 57 HRc

+ Other materials on request.
Other cutting shapes (E ; T ; X) : page 81
Available coatings : page 90
Technical options : page 83

To order :

Punch HSS Conical head 30° Solid Blank D.body L1
PB-TTNB-10-100 Blank

Punch HSS Conical head 30° Solid Rectangle D.body L1 L2 Shape dimensions Flat Position
PB-TTNR-10-100-20-P5.5-W4.1-R2-T90 Shaped

NEW

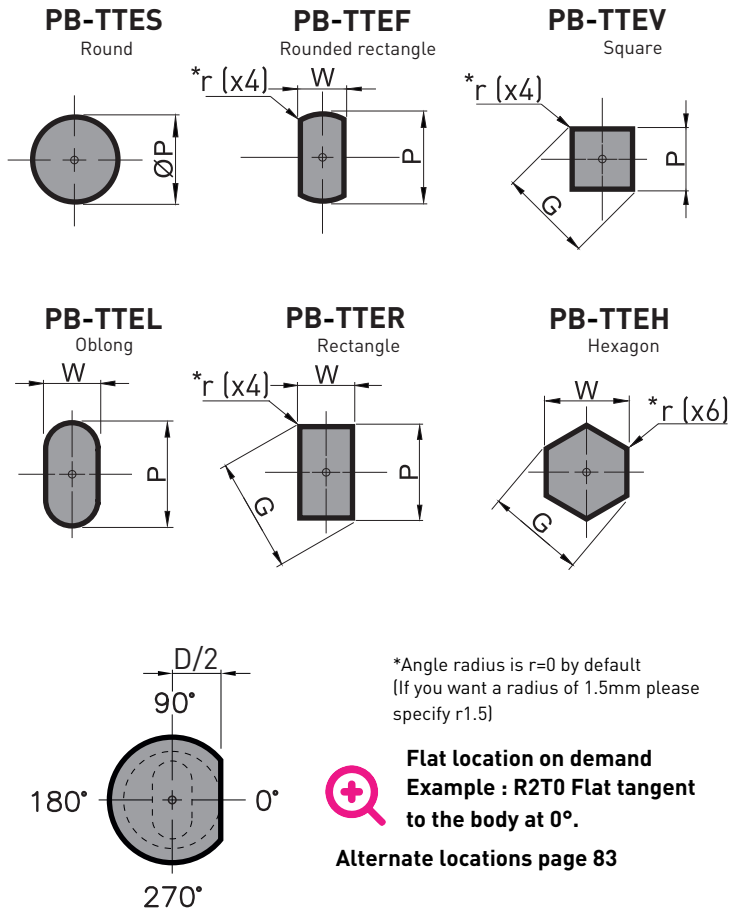
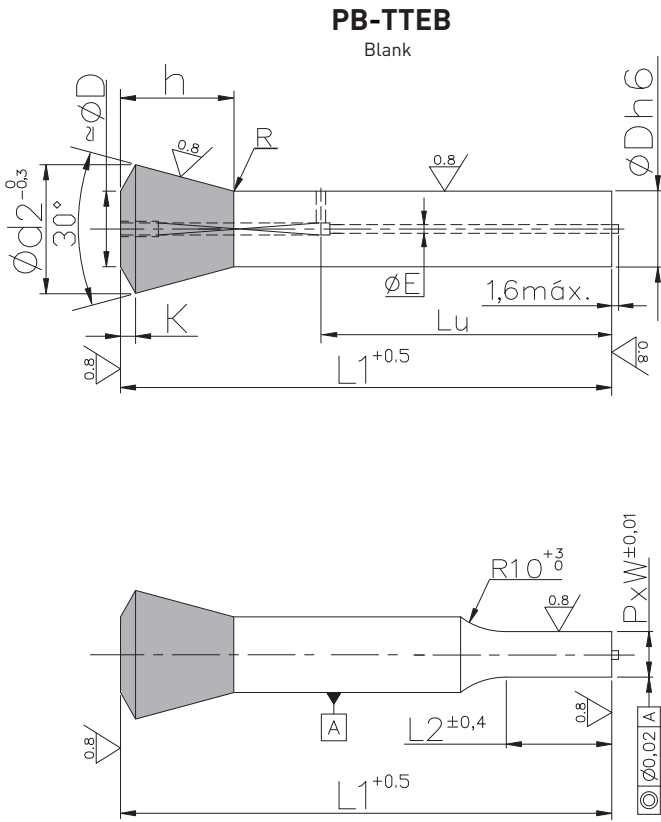

*Angle radius is r=0 by default
(If you want a radius of 1.5mm please specify r1.5)

Flat location on demand
Example : R2T0 Flat tangent to the body at 0°.

Alternate locations page 83

! $G = \sqrt{P^2 + W^2} \cdot G \leq \text{ØD} - 0,1$

Reference	Ø D	L1		L2	PB-TTES	Others shapes		Ød2	K	h	ØE
		100	120		ØP	W (min)	P / G (max)				
Shapes Material PB-TTER S L F V H (TMY) = E (TMX) = T (SPECIALS) = X	6	B		13	2,5 - 5,9	2,5	5,9	10	1	8	1,1
	8	B	B	16	3 - 7,9	3	7,9	13	1	10	1,1
	10	B	B	20	4,5 - 9,9	4,5	9,9	16	1	12	1,3
	12	B	B	20	5,8 - 11,9	5,8	11,9	19	1,5	14	1,3
	14	B	B	20	7,5 - 13,9	6	13,9	22	1,5	16	2,2
	16	B	B	20	9,5 - 15,9	7	15,9	24,7	2	18	2,2
ØD and length "L1" : Others dimensions on request.		LU			Length L2 applied by default , others dimensions on request.						
		68	68								

Matière:	Corps	Tête
B = [Z90 WDCV 06050402]	60 - 64	47 - 57 HRc

+ Other materials on request.
Other cutting shapes (E ; T ; X) : page 81
Available coatings : page 90
Technical options : page 83

To order :									
Punch HSS	Conical head 30°	Solid	Blank	D.body	L1				Blank
PB-TTEB - 10 - 100									
Punch HSS	Conical head 30°	Solid	Rectangle	D.body	L1	L2	Shape dimensions	Flat	Position
PB-TTER - 10 - 100 - 20 - P6.5 - W5.1 - R2 - T90									

P_-BLNB / P_-BHNБ

Blank
Light duty / Heavy duty

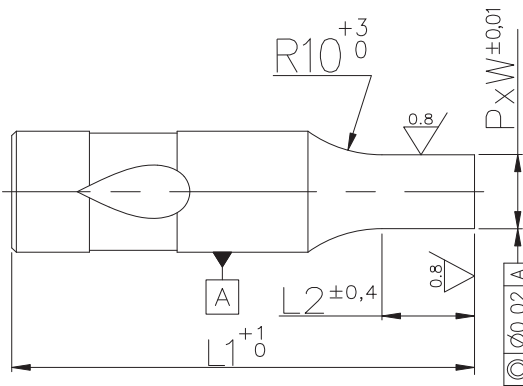
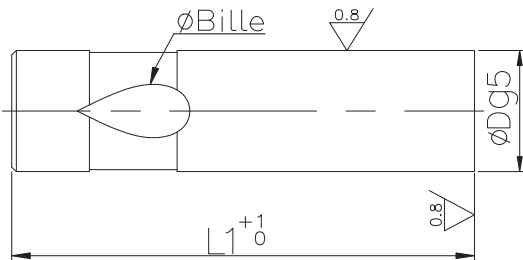

! $G = \sqrt{P^2 + W^2}$. $G \leq \text{ØD} - 0,1$

P_-BLNS / P_-BHNS P_-BLNF / P_-BHNF P_-BLNV / P_-BHNV

Round Rounded rectangle Square

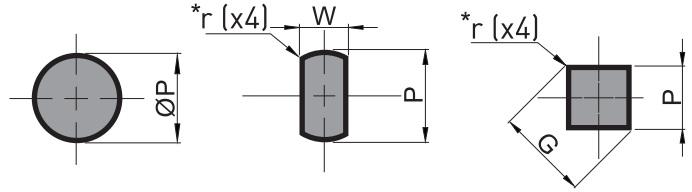

P_-BLNL / P_-BHNL P_-BLNR / P_-BHNR P_-BLNH / P_-BHNH

Oblong Rectangle Hexagon

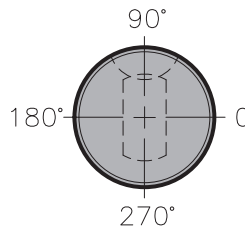
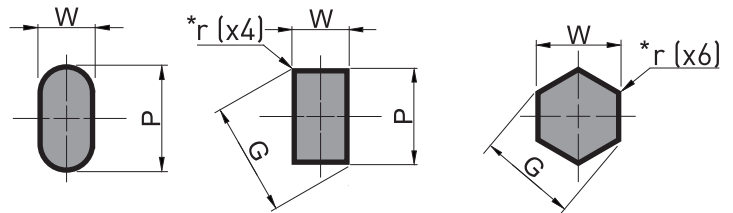

*Angle radius is r=0 by default
(If you want a radius of 1.5mm please specify r1.5)

! Shape made by default at T=90° from the ball seat as shown in the drawings following drawing opposite

Reference	Ø D	L1				L2	P_-B_NS		Others shapes		Ø Ball
		71	80	100	125		ØP	W (min)	P / G (max)		
LIGHT DUTY											
Material PA - BLNR Shapes	10	A+B	A+B	B	B	13	4,5 - 9,9	3,5	9,9	8	
	13	A+B	A+B	B	B	16	6,5 - 12,9	4,5	12,9	8	
	16	A+B	A+B	B	B	20	9,5 - 15,9	6	15,9	8	
	20	A+B	A+B	B	B	20	12,5 - 19,9	8	19,9	8	
	25	A+B	A+B	B	B	20	16,5 - 24,9	10	24,9	8	
HEAVY DUTY											
Material PB - BHNВ	10	B	B	B	B	13	4,5 - 9,9	4,5	9,9	10	
	13	B	B	B	B	16	6,5 - 12,9	6	12,9	12	
	16	B	B	B	B	20	9,5 - 15,9	6	15,9	12	
	20	B	B	B	B	20	12,5 - 19,9	8	19,9	12	
	25	B	B	B	B	20	18 - 24,9	10	24,9	12	
	40	B	B	B	B	20	30,5 - 39,9	14	39,9	12	

ØD and length "L1" : Others dimensions on request. Length L2 applied by default, others dimensions on request.

Material	Body	Head
A = (X155CrVMo.12.1)	58 - 62	40 - 50 HRc
B = (Z90 WDCV 06050402)	60 - 64	47 - 57 HRc

To order :

Punch HSS Heavy duty Solid Blank D.body L1 L2 Shape dimensions Position

PB - BHNБ - 16 - 71 Blank

PB - BHNВ - 16 - 71 - 20 - P10.2 - r1.5 - T90 Shaped

+ Other materials on request.
Other cutting shapes (E ; T ; X) : page 81
Available coatings : page 90
Technical options : page 83

P_-BLEB / P_-BHEB

Blank
Light duty / Heavy duty

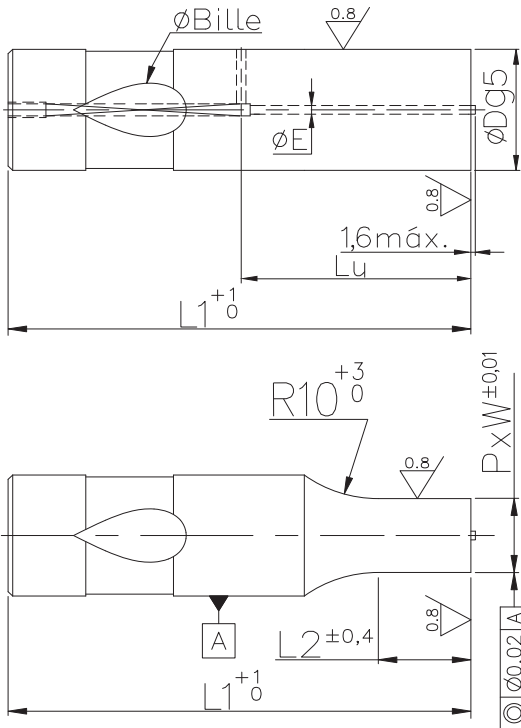

! $G = \sqrt{P^2 + W^2}$. $G \leq \text{ØD} - 0,1$

P_-BLES / P_-BHES

Round

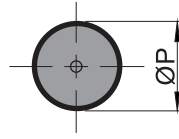

P_-BLEF / P_-BHEF

Rounded rectangle

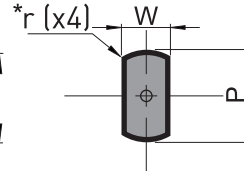

P_-BLEV / P_-BHEV

Square

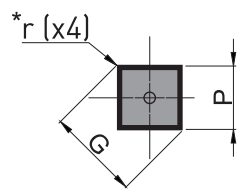

P_-BLEL / P_-BHEL

Oblong

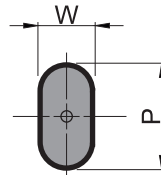

P_-BLER / P_-BHER

Rectangle

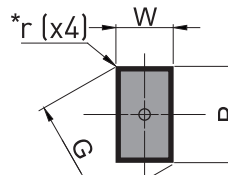

P_-BLEH / P_-BHEH

Hexagon

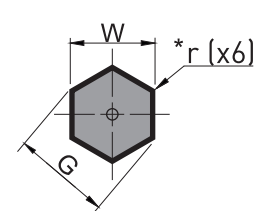

*Angle radius is r=0 by default
(If you want a radius of 1.5mm please specify r1.5)

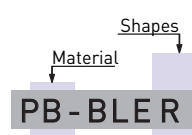
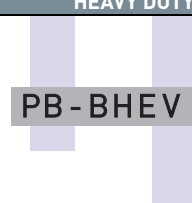

Shape made by default at T=90° from the ball seat as shown in the drawings following drawing opposite

Reference	Ø D	L1				L2	P_-B_ES		Others shapes		Ø E	Ø Ball
		71	80	100	125		ØP	W (min)	P / G (max)			
LIGHT DUTY												
 PB-BLER	10	B	B	B		13	4,5 - 9,9	4,5	9,9	1,3	8	
	13	B	B	B		16	6,5 - 12,9	6	12,9	1,3	8	
	16	B	B	B		20	9,5 - 15,9	7	15,9	2,2	8	
	20	B	B	B		20	12,5 - 19,9	8	19,9	2,2	8	
	25	B	B	B		20	16,5 - 24,9	10	24,9	2,2	8	
HEAVY DUTY												
 PB-BHEV	10	B	B	B		13	5,5 - 9,9	5,5	9,9	1,3	10	
	13	B	B	B	B	16	8 - 12,9	8	12,9	1,3	12	
	16	B	B	B	B	20	9,5 - 15,9	9,5	15,9	2,2	12	
	20	B	B	B	B	20	12,5 - 19,9	12,5	19,9	2,2	12	
	25	B	B	B	B	20	18 - 24,9	18	24,9	2,2	12	
	32	B	B	B	B	20	24 - 31,9	18	31,9	2,2	12	
40	B	B	B	B	20	30,5 - 39,9	18	39,9	2,2	12		
ØD and length "L1" : Others dimensions on request.		LU				<input type="checkbox"/> Length L2 applied by default, others dimensions on request.						
		39	48	68	68							

Matière:	Corps	Tête
B = [Z90 WDCV 06050402]	60 - 64	47 - 57 HRc

+ Other materials on request.
Other cutting shapes (E ; T ; X) : page 81
Available coatings : page 90
Technical options : page 83

To order :

Blank

Punch HSS Light duty Ejector Blank D.body L1
P B - BLEB - 16 - 71

Shaped

Punch HSS Light duty Ejector Oblong D.body L1 L2 Shape dimensions Position
P B - BLEL - 16 - 71 - 20 - P15.2 - W8.2 - T0

P_-BJNB / P_-BKNB

Blank
Light duty / Heavy duty

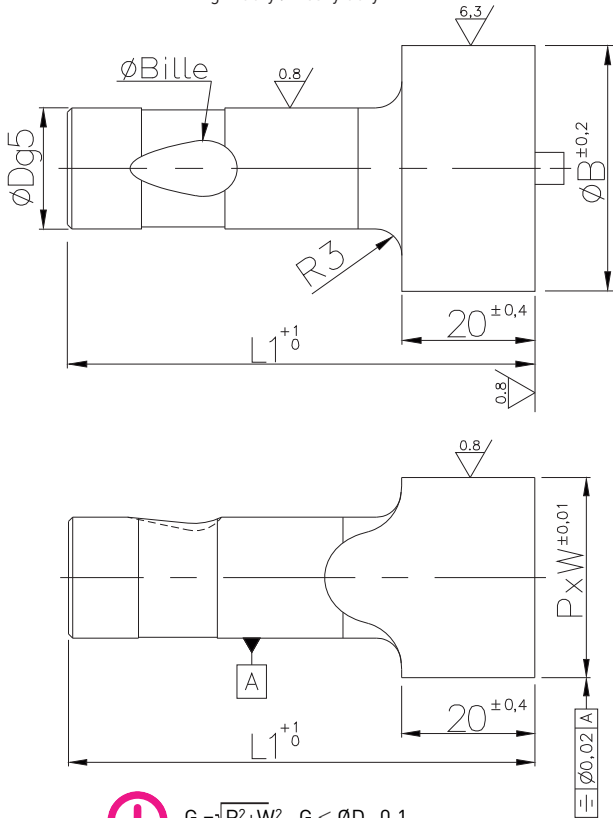

! $G = \sqrt{P^2 + W^2} \cdot G \leq \varnothing D - 0,1$

P_-BJNS / P_-BKNS

Round

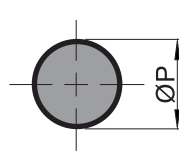

P_-BJNF / P_-BKNF

Rounded rectangle

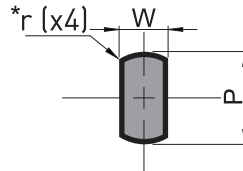

P_-BJNV / P_-BKNV

Square

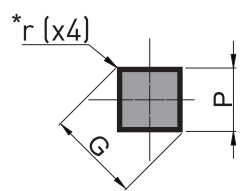

P_-BJNL / P_-BKNL

Oblong

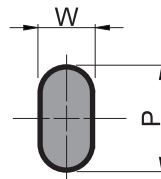

P_-BJNR / P_-BKNR

Rectangle

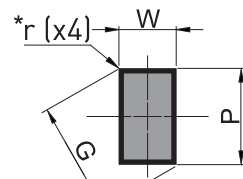

P_-BJNH / P_-BKNH

Hexagon

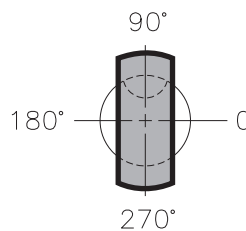
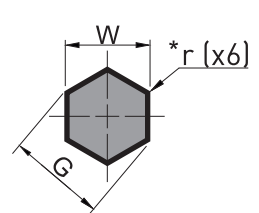

*Angle radius is $r=0$ by default
(If you want a radius of 1.5mm please specify $r1.5$)

! Shape made by default at $T=90^\circ$ from the ball seat as shown in the drawings following drawing opposite

Reference	$\varnothing D$	L1		P_-B_NS	Others shapes	$\varnothing B$	\varnothing Ball
		71	80	$\varnothing P$	G (max)		
LIGHT DUTY							
 Material Shapes PA - BJNL	10	B	A+B	12 - 20	20	20,5	8
	13	B	A+B	15 - 29,5	29,5	30	8
	16	B	A+B	18 - 32	32	32,5	8
	20	B	A+B	22 - 38	38	38,5	8
	25	B	A+B	28 - 47,5	47,5	48	8
	32	B	A+B	35 - 49,5	49,5	50	8
	40	B	A+B	43 - 55,5	55,5	56	8
HEAVY DUTY							
 Material Shapes PB - BKNL	32	B	B	35 - 49,5	49,5	50	12
	40	B	B	43 - 55,5	55,5	56	12

Material	Body	Head
A = (X155CrVMo.12.1)	58 - 62	40 - 50 HRc
B = (Z90 WDCV 06050402)	60 - 64	47 - 57 HRc

To order :

Punch HSS Light duty Solid Blank D.body L1
PB - BJNB - 16 - 71 Blank

Punch HSS Light duty Solid Oblong D.body L1 Shape dimensions Position
PB - BJNL - 16 - 71 - P28.2 - W20.5 - T0 Shaped

+ Other materials on request.
Other cutting shapes (E ; T ; X) : page 81
Available coatings : page 90
Technical options : page 83

DIE BUTTONS CODIFICATIONS

A = Material

X155CrVMo12.1/1.2379/HWS/D2	A
Z90/HSS/1.3343/M2/HS 6.5.2	B
Carbure	C
ASP23/1.3395/M32/HS 6.5.3	E
XII0CrMoV8-2	K
M4/1.3351/HS 6.5.4	S

C = Type of relief

WEDM Blank	W
Counterbore relief	C
Taper relief	D
Solid	N

D = Metric die
(E = inches dimensions)

Ø Body (mm)

Total length (mm)

H
Working Height

DA-HMCR-10-32-8-P6.3-W4.9

P - W
Shape dimensions

HM = Type

Headed, m5 Body (ISO8977)	HM
Headed, h5 Body (CNOMO)	HH
Straight, m5 Body (ISO8977)	SM
Straight, h5 Body (CNOMO)	SH
Straight, n5 Body/j6 (NAAMS)	SN
Straight, h5 Body, Screw Lock (CNOMO)	SC
Low profile straight reversible, h5 Body (CNOMO)	SR
Low Profile Straight Non-Reversible, h5 Body (CNOMO)	SS
Ball-lock	BL

R = Shapes

Blank	B
Blank with alteration	A
Round	S
Oblong	L
Square	V
Rectangle	R
Rounded rectangle	F
Hexagon	H
Classified Shapes - TMX	T
Classified Shapes - TMY	E
Special	X

HEADLESS DIE BUTTON TAPER RELIEF

ISO 8977 Standard - AFNOR NFE 63080

D_-SMWB
D_-SMD
D_-SHWB
D_-SHD

D_-SMWB ØDm5

D_-SHWB ØDh5

Blank

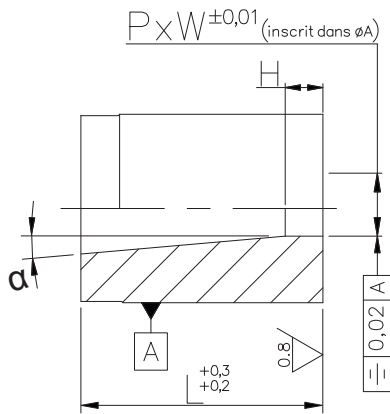
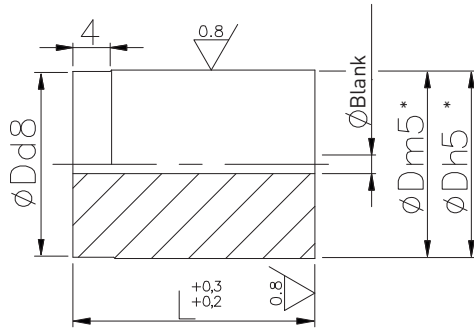

α = 1° by default
H = 5 by default

D_-SMDS ØDm5

D_-SHDS ØDh5

Round

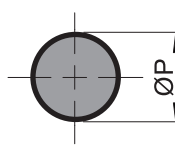

D_-SMDL ØDm5

D_-SHDL ØDh5

Oblong

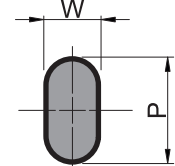

D_-SMDF ØDm5

D_-SHDF ØDh5

Rounded rectangle

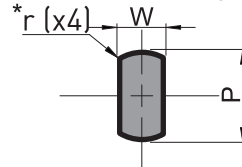

D_-SMDF ØDm5

D_-SHDF ØDh5

Rectangle

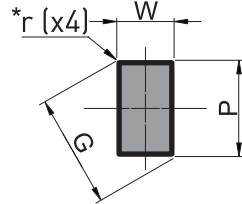

D_-SMDV ØDm5

D_-SHDV ØDh5

Square

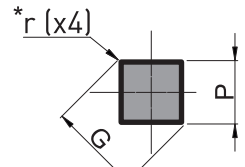

D_-SMDH ØDm5

D_-SHDH ØDh5

Hexagon

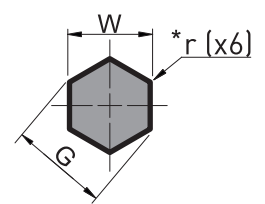

*Minimum Angle radius is r=0.15 by default
(If you want a radius of 2mm please specify r2)

Flat location on demand
Example : R2T0 Flat 1.5 x 5mm at 0°.



Alternate locations page 86



$$G = \sqrt{P^2 + W^2} ; G \leq A$$

Reference	Ø D	L				D_-S_DS	Others shapes		Ø Blank	Ø A Max
		20	25	32	35	ØP	W (min)	P / G (max)		
Shapes Tol. ØD Material DA-SMDR B H F V H (TMY) = E (TMX) = T (SPECIALS) = X	6	A+B	A+B			1,5 - 2,5	1,5	2,5	1	2,5
	8	A+B	A+B			1,5 - 3,5	1,5	3,5	1	3,5
	10	A+B	A+B	A+B		2 - 4,5	2	4,5	1,5	4,5
	13	A+B	A+B	A+B		2 - 6,7	2	6,7	1,5	6,7
	16	A+B	A+B	A+B	A+B	2,5 - 8,2	2,5	8,2	2	8,2
	20	A+B	A+B	A+B	A+B	2,5 - 10,7	2,5	10,7	2	10,7
	22	A+B	A+B	A+B	A+B	2,5 - 13	2,5	13	2	13
	25		A+B	A+B	A+B	2,5 - 16	2,5	16	2	16
	32			A+B		2,5 - 19,4	2,5	19,4	2	19,4
	38			A+B		2,5 - 23	2,5	23	2	23
	40			A+B		2,5 - 26,4	2,5	26,4	2	26,4
	45			A+B		2,5 - 27	2,5	27	2	27
	50			A+B		2,5 - 35,7	2,5	35,7	2	35,7

ØD and length "L" : Others dimensions on request. * Height H is 5mm by default

Material	Body	Head
A = (X155CrVMo.12.1)	58 - 62	40 - 50 HRc
B = (Z90 WDCV 06050402)	60 - 64	47 - 57 HRc

To order :

Die HWS	Straight Body (m5)	EDM	Blank	D body	L	Blank
DA-SMWB-16-25						
Die HWS	Straight Body (m5)	Tapered	Oblong	D body	L	H
DA-SMDL-16-25-5-P8.2-W5.2-PA1-R2-T0						



Other materials on request.
Other cutting shapes (E ; T ; X) : page 81

Available coatings : page 90
Technical options : page 86

D_-SMCB ØDm5
D_-SHCB ØDh5
Blank

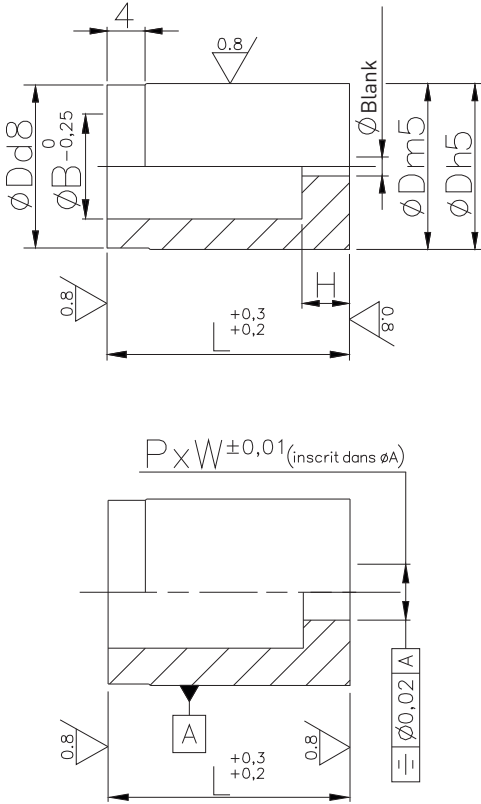

D_-SMCS ØDm5
D_-SHCS ØDh5
Round

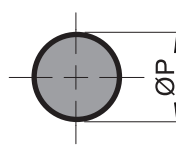

D_-SMCF ØDm5
D_-SHCF ØDh5
Rounded rectangle

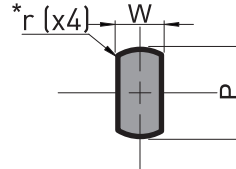

D_-SMCV ØDm5
D_-SHCV ØDh5
Square

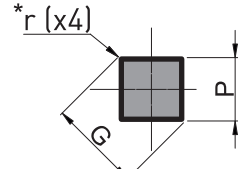

D_-SMCL ØDm5
D_-SHCL ØDh5
Oblong

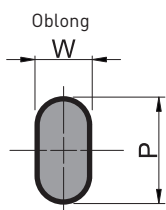

D_-SMCF ØDm5
D_-SHCF ØDh5
Rectangle

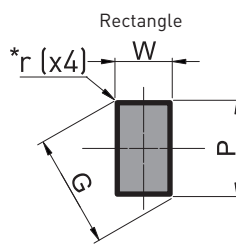

D_-SMCH ØDm5
D_-SHCH ØDh5
Hexagon

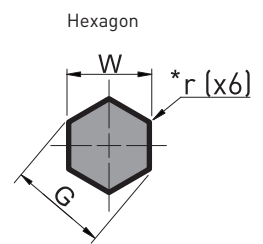

*Minimum Angle radius is r=0.15 by default
(If you want a radius of 2mm please specify r2)

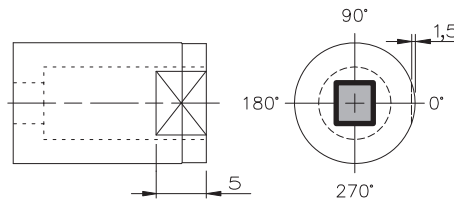

Flat location on demand
Example : R2T0 Flat 1.5 x 5mm at 0°.

Alternate locations page 86

! $G = \sqrt{P^2 + W^2}$; $G \leq A$

Reference	Ø D	L				H	D_-S_CS	Others shapes		Ø B	Ø E	Ø A Max
		20	25	32	35		ØP	W (min)	P / G (max)			
<p>Shapes: S, L, F, V, H</p> <p>Material: A, B</p> <p>DA - SMCR</p> <p>(TMY) = E</p> <p>(TMX) = T</p> <p>(SPECIALS) = X</p>	6	A+B	A+B			3	1,5 - 3	1,5	3	3,5	1	3
	8	A+B	A+B			4	1,5 - 3,5	1,5	3,5	4	1	3,5
	10	A+B	A+B	A+B		5 8	2 - 5,0	2	5	5,8	1,5	5
	13	A+B	A+B	A+B		5 8	2 - 7,0	2	7	8	1,5	7
	16	A+B	A+B	A+B	A+B	5 8	2,5 - 9,0	2,5	9	9,5	2	9
	20	A+B	A+B	A+B	A+B	5 8	2,5 - 11	2,5	11	12	2	11
	22	A+B	A+B	A+B	A+B	8	2,5 - 13	2,5	13	14	2	13
	25		A+B	A+B	A+B	5 8	2,5 - 16	2,5	16	17,3	2	16
	32			A+B		8	2,5 - 20	2,5	20	20,7	2	20
	38			A+B		8	2,5 - 26	2,5	26	27	2	26
	40			A+B		8	2,5 - 27	2,5	27	27,7	2	27
	45			A+B		8	2,5 - 35	2,5	35	36	2	35
	50			A+B		8	2,5 - 36	2,5	36	37	2	36

ØD and length "L" : Others dimensions on request. Height H applied by default others dimensions on request.

Material	Body	Head
A = (X155CrVMo.12.1)	58 - 62	40 - 50 HRc
B = (Z90 WDCV 06050402)	60 - 64	47 - 57 HRc

To order :

Die HWS Straight Body (InSb) Counterbore Blank D body L H
DA - S M C B - 16 - 25 - 5 Blank

Die HWS Straight Body (InSb) Tapered Square D body L H Shape dimensions Radius Flat Position
DA - S M C V - 16 - 25 - 5 - P6 - r1.5 - R2 - T90 Shaped

+ Other materials on request.
Other cutting shapes (E ; T ; X) : page 81
Available coatings : page 90
Technical options : page 86

HEADED DIE BUTTON TAPER RELIEF

ISO 8977 Standard - AFNOR NFE 63080

D_-HMWB
D_-HMD
D_-HHWB
D_-HHD

D_-HMWB ØDm5

D_-HHWB ØDh5

Blank

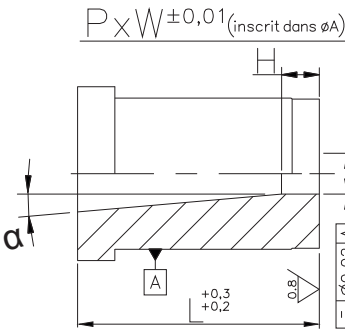
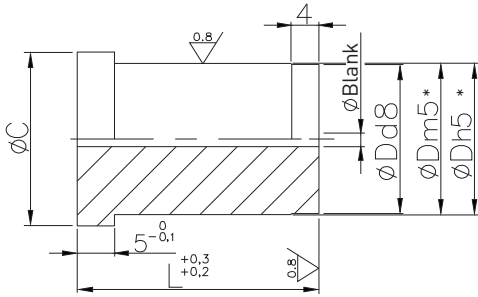

α = 1° by default

H = 5 by default

D_-HMDS ØDm5

D_-HHDS ØDh5

Round

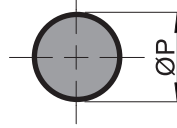

D_-HMDL ØDm5

D_-HHDL ØDh5

Oblong

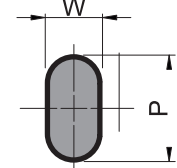

D_-HMDF ØDm5

D_-HHDF ØDh5

Rounded rectangle

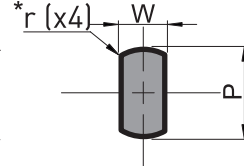

D_-HMDR ØDm5

D_-HHR ØDh5

Rectangle

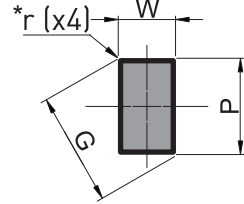

D_-HMDV ØDm5

D_-HHDV ØDh5

Square

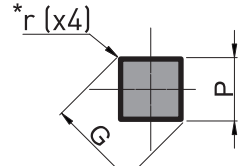

D_-HMDH ØDm5

D_-HHDH ØDh5

Hexagon

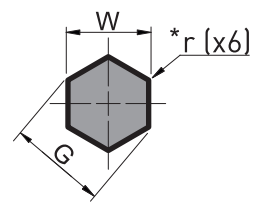

*Minimum Angle radius is r=0.15 by default
(If you want a radius of 2mm please specify r2)

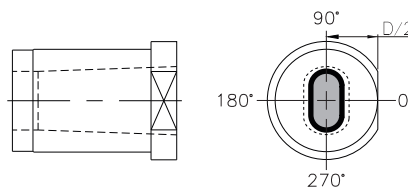

Flat location on demand
Example : R2T0 Flat 1.5 x 5mm at 0°.

Alternate locations page 86



$$G = \sqrt{P^2 + W^2} ; G \leq A$$

Reference	Ø D	L				D -H DS	Others shapes		Ø C	Ø Blank	Ø A Max
		20	25	32	35	ØP	W (min)	P / G (max)			
Shapes Tol. ØD Material DA - HMDR B H F V H [TMY] = E [TMX] = T [SPECIALS] = X	6	A+B				1,5 - 2,5	1,5	2,5	9	1	2,5
	8	A+B	A+B			1,5 - 3,5	1,5	3,5	11	1	3,5
	10	A+B	A+B	A+B	A+B	2 - 4,5	2	4,5	13	1,5	4,5
	13	A+B	A+B	A+B	A+B	2 - 6,7	2	6,7	16	1,5	6,7
	16	A+B	A+B	A+B	A+B	2,5 - 8,2	2,5	8,2	19	2	8,2
	20	A+B	A+B	A+B	A+B	2,5 - 10,7	2,5	10,7	23	2	10,7
	22	A+B	A+B	A+B	A+B	2,5 - 13	2,5	13	25	2	13
	25		A+B	A+B	A+B	2,5 - 16	2,5	16	28	2	16
	32			A+B		2,5 - 19,4	2,5	19,4	35	2	19,4
	40			A+B		2,5 - 26,4	2,5	26,4	43	2	26,4
	50			A+B		2,5 - 35,7	2,5	35,7	53	2	35,7

ØD and length "L" : Others dimensions on request. * Height H is 5mm by default

Material	Body	Head
A = (X155CrVMo.12.1)	58 - 62	40 - 50 HRc
B = (Z90 WDCV 06050402)	60 - 64	47 - 57 HRc

To order :

Die	HWS	Headed Body (r15)	EDM	Blank	D body	L	Blank				
DA - H M W B - 20 - 25											
Die	HWS	Headed Body (r15)	Tapered	Oblong	D body	L	H	Shape dimensions	Relief 2°	Flat	Shaped Position
DA - H M D L - 20 - 25 - 5 - P8 - W5 - PA2 - R2 - T0											



Other materials on request.
Other cutting shapes (E ; T ; X) : page 81

Available coatings : page 90

Technical options : page 86

D_-HM CB ØDm5
D_-HH CB ØDh5
 Blank

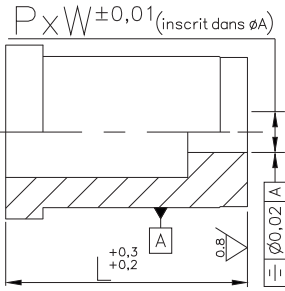
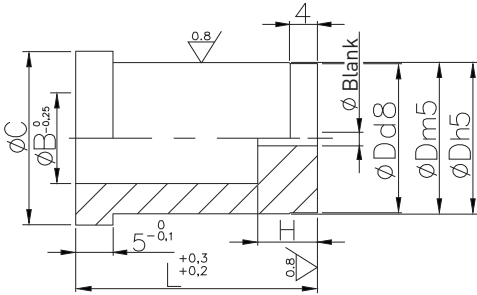

D_-HM CS ØDm5
D_-HH CS ØDh5
 Round

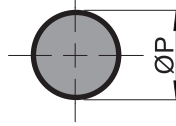

D_-HM CL ØDm5
D_-HH CL ØDh5
 Oblong

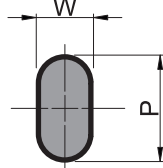

D_-HM CF ØDm5
D_-HH CF ØDh5
 Rounded rectangle

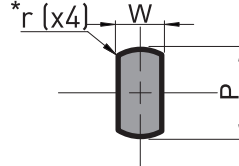

D_-HM CR ØDm5
D_-HH CR ØDh5
 Rectangle

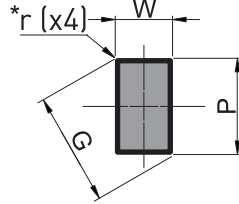

D_-HM CV ØDm5
D_-HH CV ØDh5
 Square

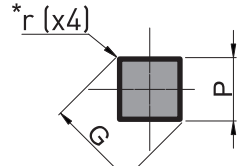

D_-HM CH ØDm5
D_-HH CH ØDh5
 Hexagon

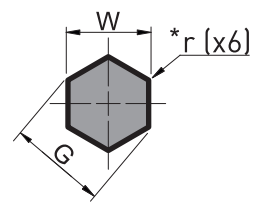

*Minimum Angle radius is r=0.15 by default
 (If you want a radius of 2mm please specify r2)

! $G = \sqrt{P^2 + W^2}$; $G \leq A$

+ Flat location on demand
 Example : R2T0 Flat 1.5 x 5mm at 0°.
 Alternate locations page 86

Reference	Ø D	L				H	D_-H_CS		Others shapes		Ø E	Ø C	Ø B	Ø A Max
		20	25	32	35		Ø P	W (min)	P / G (max)					
Shapes Tol. ØD Material DA - HM CR B H F V H (TMY) = E (TMX) = T (SPECIALS) = X	6	A+B				3	1,5 - 3	1,5	3	1	9	3,5	3	
	8	A+B	A+B			4	1,5 - 3,5	1,5	3,5	1	11	4	3,5	
	10	A+B	A+B	A+B	A+B	5 8	2 - 5,0	2	5	1,5	13	5,8	5	
	13	A+B	A+B	A+B	A+B	5 8	2 - 7,0	2	7	1,5	16	8	7	
	16	A+B	A+B	A+B	A+B	5 8	2,5 - 9,0	2,5	9	2	19	9,5	9	
	20	A+B	A+B	A+B	A+B	5 8	2,5 - 11	2,5	11	2	23	12	11	
	22	A+B	A+B	A+B	A+B	8	2,5 - 13	2,5	13	2	25	14	13	
	25		A+B	A+B	A+B	5 8	2,5 - 16	2,5	16	2	28	17,3	16	
	32			A+B		8	2,5 - 20	2,5	20	2	35	20,7	20	
	40			A+B		8	2,5 - 27	2,5	27	2	43	27,7	27	
	50			A+B		8	2,5 - 36	2,5	36	2	53	37	36	

ØD and length "L" : Others dimensions on request. Height H applied by default others dimensions on request.

Material	Body	Head
A = (X155CrVMo.12.1) B = (Z90 WDCV 06050402)	58 - 62 60 - 64	40 - 50 HRc 47 - 57 HRc

To order :

Die HWS Headed Body (min) Counterbore Blank D.body L H
DA - HM CB - 16 - 25 - 5

Die HWS Headed Body (min) Counterbore Oblong D.body L H Shape dimensions Flat Position
DA - HM CL - 16 - 25 - 5 - P8.2 - W5.2 - R2 - T90

+ Other materials on request.
 Other cutting shapes (E ; T ; X) : page 81
 Available coatings : page 90
 Technical options : page 86

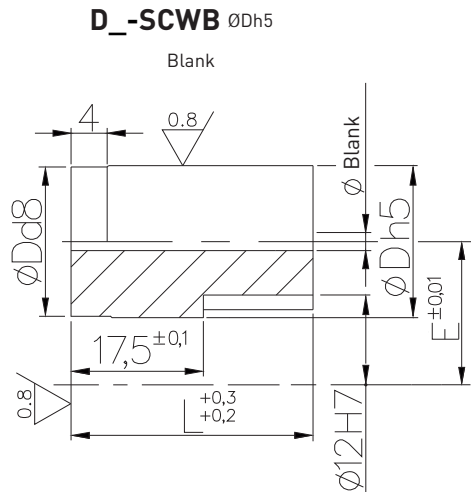

D_-SCDS ØDh5
Round

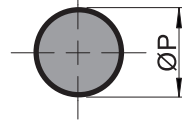

D_-SCDF ØDh5
Rounded rectangle

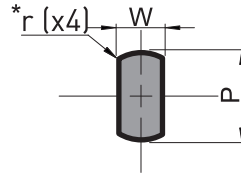

D_-SCDV ØDh5
Square

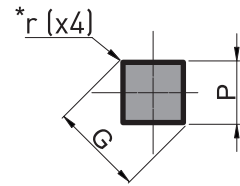

D_-SCDL ØDh5
Oblong

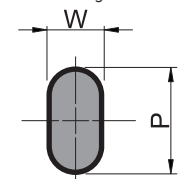

D_-SCDR ØDh5
Rectangle

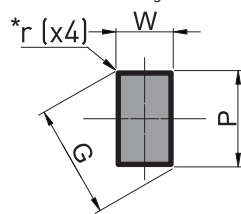

D_-SCDH ØDh5
Hexagon

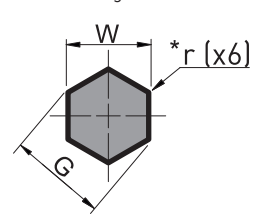

*Minimum Angle radius is r=0.15 by default
(If you want a radius of 2mm please specify r2)

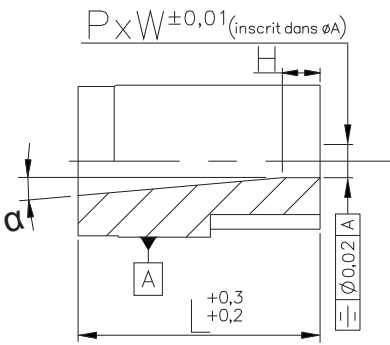

$\alpha = 1^\circ$ by default
H = 5 by default

! $G = \sqrt{P^2 + W^2}$; $G \leq A$

Possible die mounting

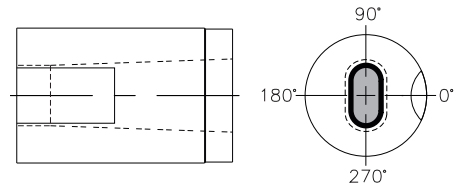
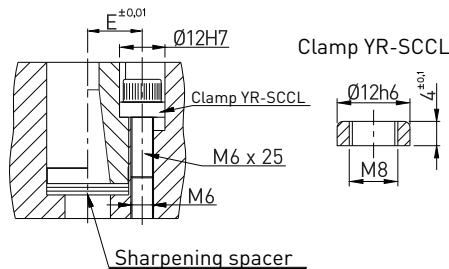

! Shape is made at T=0° by default as per drawing above

+ Sharpening spacers page 67
Mounting accessories page 66

Reference	Ø D	L	D_-SCDS	Others shapes		E	Ø Blank	Ø A Max	
		32	ØP	W (min)	P / G (max)				
Shapes Material DA - SCDR K S L F V H E T X (TMY) = (TMX) = (SPECIALS) =	16	A+K	2,5 - 8,2	2,5	8,2	11,5	2	8,2	
	20	A+K	2,5 - 10,7	2,5	10,7	13,5	2	10,7	
	25	A+K	2,5 - 16	2,5	16	16	2	16	
	32	A+K	2,5 - 19,4	2,5	19,4	19,5	2	19,4	
	40	A+K	2,5 - 26,4	2,5	26,4	23,5	2	26,4	
	50	A+K	2,5 - 35,7	2,5	35,7	28,5	2	35,7	
ØD and length "L" : Others dimensions on request.							* Height H is 5mm by default		

Material	Body
A = (X155CrVMo.12.1)	58 - 62 HRc
K = (X110CrMoV8-T6)	62 - 66 HRc

+ Other materials on request.
Other cutting shapes (E ; T ; X) : page 81
Available coatings : page 90
Technical options : page 86

To order :

Die	HWS	Key located	Body (HWS)	EDM	Blank	D body	L
DA - SCWB - 20 - 32							
Die	HWS	Key located	Tapered	Oblong	D body	L	H
DA - SCDL - 20 - 32 - 5 - P7.2 - W5.2 - PA1 - T0							

Blank
Shaped
Relief 1°
Position

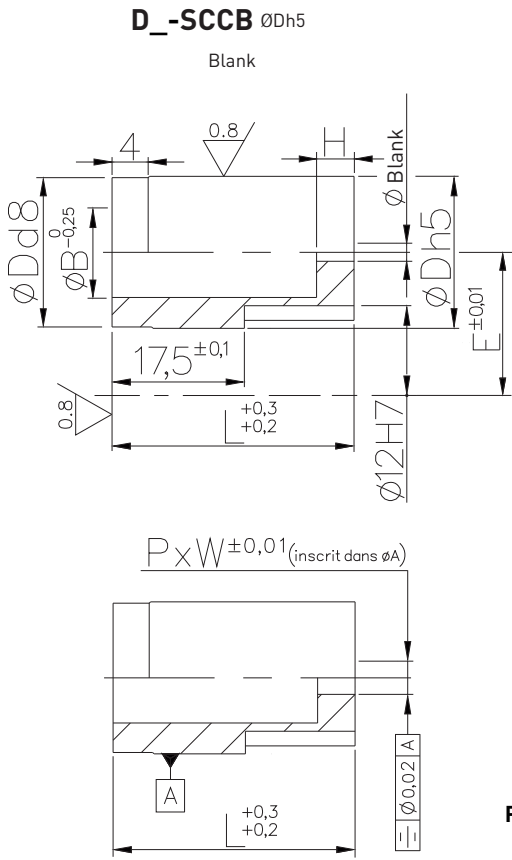

! $G = \sqrt{P^2 + W^2}$; $G \leq A$

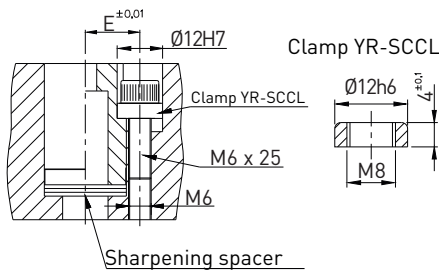

D_-SCCS $\varnothing Dh5$
Round

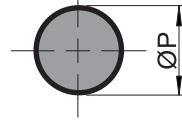

D_-SCCL $\varnothing Dh5$
Oblong

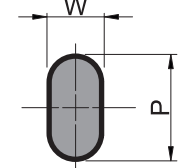

D_-SCCF $\varnothing Dh5$
Rounded rectangle

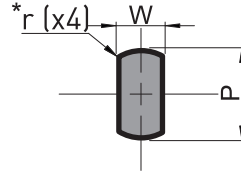

D_-SCCR $\varnothing Dh5$
Rectangle

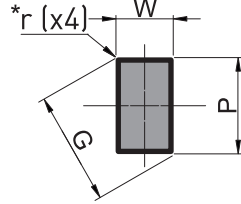

D_-SCCV $\varnothing Dh5$
Square

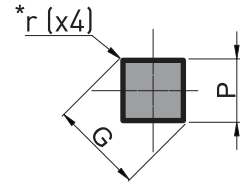

D_-SCCH $\varnothing Dh5$
Hexagon

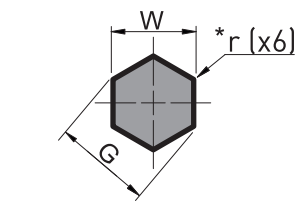

*Minimum Angle radius is $r=0.15$ by default
(If you want a radius of 2mm please specify r2)

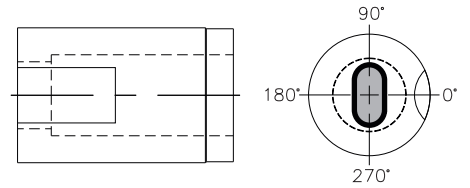

Shape is made at T=0° by default as per drawing above



**Sharpening spacers page 67
Mounting accessories page 66**

Reference	$\varnothing D$	L 32	H		D_-SCCS			Others shapes		$\varnothing B$	E	$\varnothing A$	$\varnothing \text{Blank}$
					$\varnothing P$	W (min)	P / G (max)						
Shapes Material DA - SCCR K (TMY) = E (TMX) = T (SPECIALS) = X	16	A+K	5	8	2,5 - 9,0	2,5	9	9,5	11,5	9	2		
	20	A+K	5	8	2,5 - 11	2,5	11	12	13,5	11	2		
	25	A+K	5	8	2,5 - 16	2,5	16	17,3	16	16	2		
	32	A+K	5	8	2,5 - 20	2,5	20	20,7	19,5	20	2		
	40	A+K	5	8	2,5 - 27	2,5	27	27,7	23,5	27	2		
	50	A+K	5	8	2,5 - 36	2,5	36	37	28,5	36	2		

$\varnothing D$ and length "L" : Others dimensions on request. Height H applied by default others dimensions on request.

Material	Body
A = (X155CrVMo.12.1)	58 - 62 HRc
K = (X110CrMoV8-T6)	62 - 66 HRc

To order :

Die HWS Key located Body (H5) Counter-bore Blank D.body L H
DA - S C C B - 20 - 32 - 5

Die HWS Key located Body (H5) Counter-bore Oblong D.body L H Shape dimensions Position
DA - S C C L - 20 - 32 - 5 - P8.2 - W5.2 - T0

+ **Other materials on request.**
Other cutting shapes (E ; T ; X) : page 81
Available coatings : page 90
Technical options : page 86

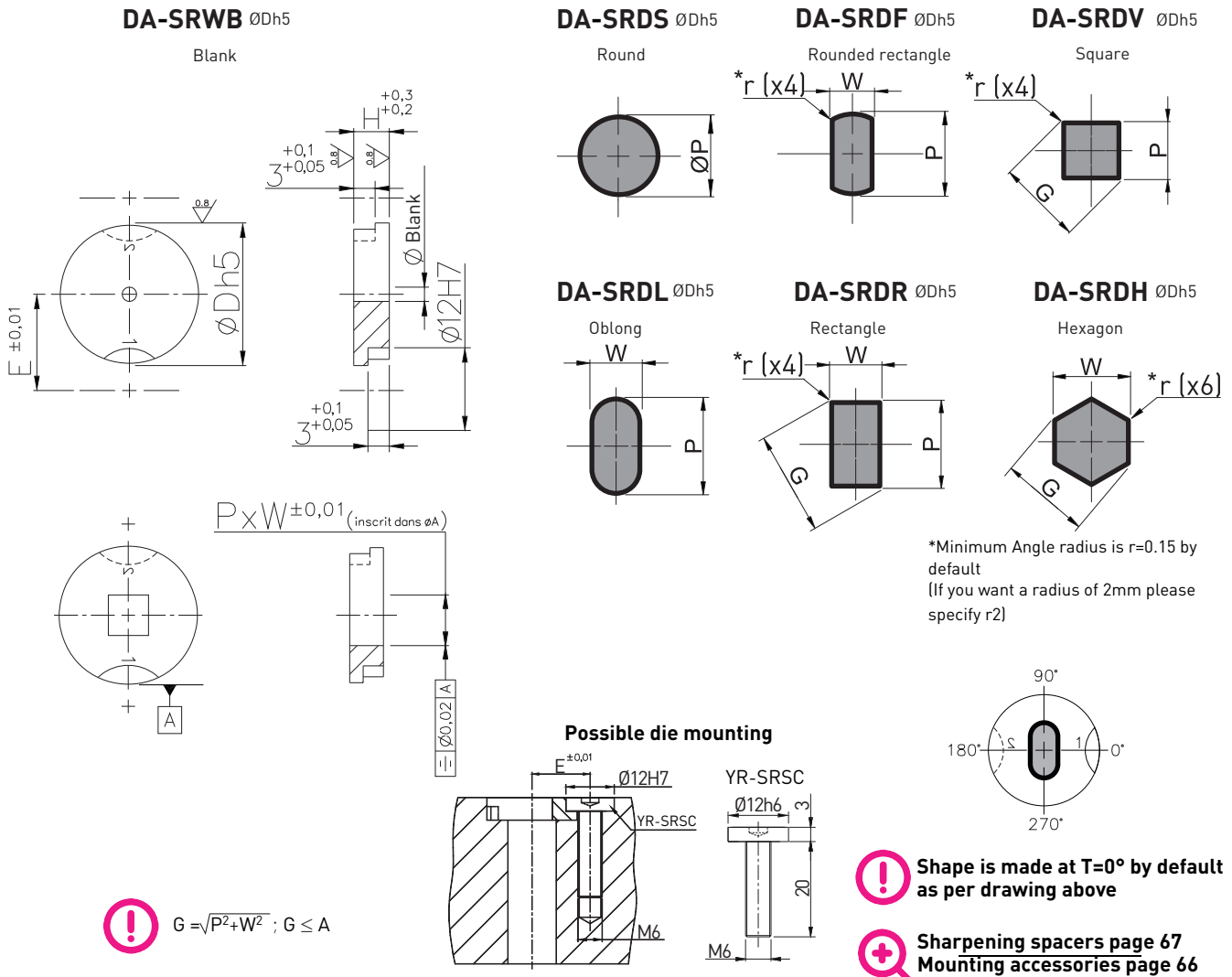

! Shape is made at T=0° by default as per drawing above

+ Sharpening spacers page 67
Mounting accessories page 66

Reference	Ø D	H			DA-SRDS	Others shapes		E	Ø Blank	Ø A
					Ø P	W (min)	P / G (max)			
Shapes Material DA-SRDR (TMY) = E (TMX) = T (SPECIALS) = X	13	5	8		2,5 - 7,0	2	7	10,5	1,5	7
	16	5	8	10	2,5 - 9,0	2,5	9	11,5	2	9
	20	5	8	10	2,5 - 11	2,5	11	13,5	2	11
	25	5	8	10	2,5 - 16	2,5	16	16	2	16
	32	5	8	10	2,5 - 20	2,5	20	19,5	2	20
	40	5	8		2,5 - 27	2,5	27	23,5	2	27
	50	5	8		2,5 - 36	2,5	36	28,5	2	36
ØD and length "L" : Others dimensions on request.					□ Height H applied by default others dimensions on request.					

Material	Body
A = [X155CrVMo.12.1]	58 - 62 HRc

+ Other materials on request.
Other cutting shapes (E ; T ; X) : page 81
Available coatings : page 90
Technical options : page 86

To order :

Die HW/S Reversible Blank D.body H
DA-SRWB-20-5

Die HW/S Reversible Rectangle D.body H Shape dimensions Radius Position
DA-SRDR-20-5-P8.2-W5.2-r1.2-T90

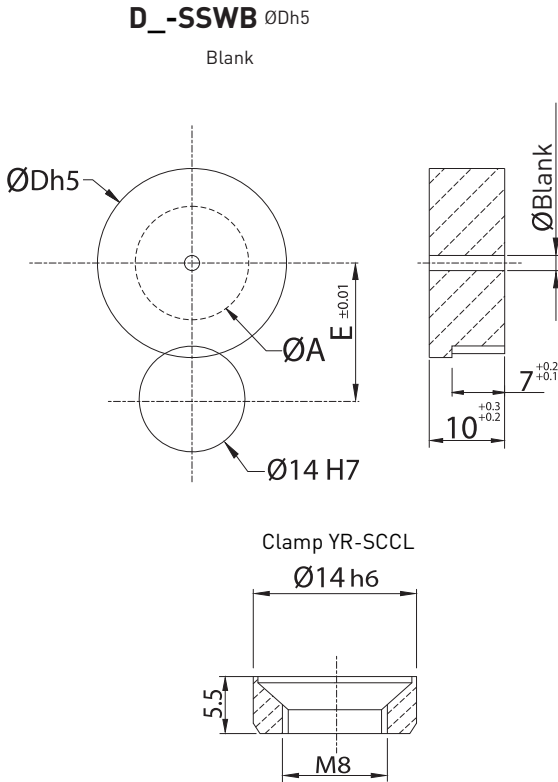

D_-SSDS ØDh5
Round

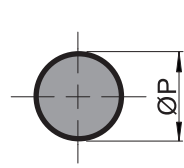

D_-SSDF ØDh5
Rounded rectangle

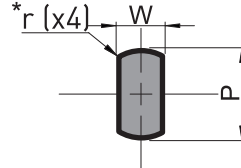

D_-SSDV ØDh5
Square

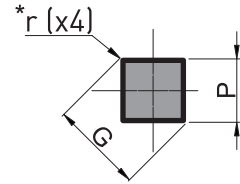

D_-SSDL ØDh5
Oblong

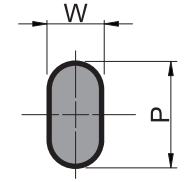

D_-SSDR ØDh5
Rectangle

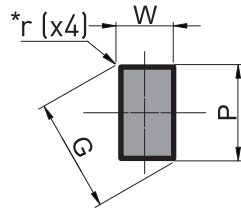

D_-SSDH ØDh5
Hexagon

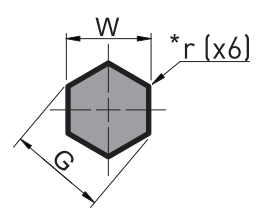

*Minimum Angle radius is r=0.15 by default
(If you want a radius of 2mm please specify r2)



**Fastened by screw M6 (FHC)
M8 screw extraction**
Not supplied

Clamp YR-SSCL : page 31

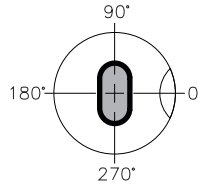

Shape is made at T=0° by default as per drawing above

Reference	Ø D	Ø E	Ø Blank	Ø A Max
<p>Shapes →</p> <p>Material →</p> <p>DA-SSDR</p> <p>K</p> <p>(TMY) = E (TMX) = T (SPECIALS) = X</p>	13	11,5	1,5	7
	16	12,5	2	9
	20	14	2	10
	25	16,5	2	15
	32	20	2	19
	40	24,5	2	27
	50	29,5	2	36

Material	Body
A = (X155CrVMo.12.1)	58 - 62 HRc
K = (X110CrMoV8-T6)	62 - 66 HRc



**Other materials on request.
Other cutting shapes (E ; T ; X) : page 81**

Available coatings : page 90
Technical options : page 86

To order :

Die HWS	No - Reversible	Blank	D.body	H	Blank
DA-SSWB-25-10					
Die HWS	No - Reversible	Oblong	D.body	H	Shaped
DA-SSDL-25-10-P8.2-W5.2-T90					

DA-BLCB ØDg5

Blank

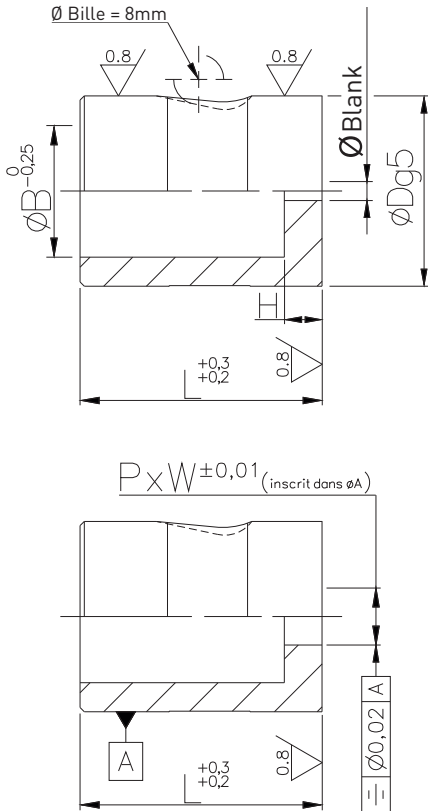

DA-BLCS ØDg5

Round

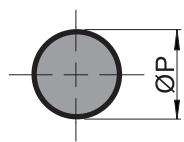

DA-BLCF ØDg5

Rounded rectangle

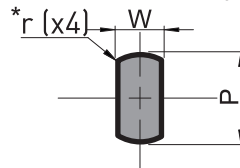

DA-BLCV ØDg5

Square

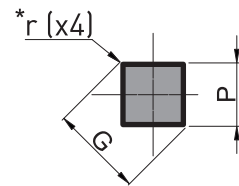

DA-BLCL ØDg5

Oblong

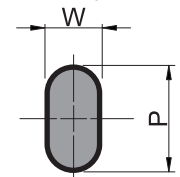

DA-BLCR ØDg5

Rectangle

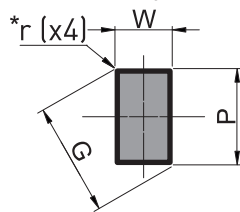

DA-BLCH ØDg5

Hexagon

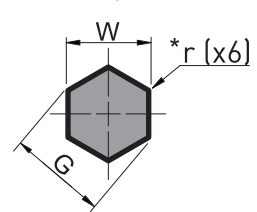

*Angle radius is r=0 by default
(If you want a radius of 1.5mm please specify r1.5)

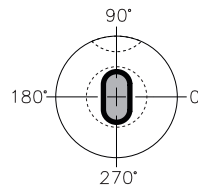

Shape made by default at T=90° from the ball seat as shown in the drawings following drawing opposite



$$G = \sqrt{P^2 + W^2} ; G \leq A$$

Reference	Ø D	L	H	DA-BLCS	Others shapes		Ø B	Ø Blank	Ø A
		32		ØP	W (min)	P / G (max)			
Shapes S L DA - BLCR F V H (TMY) = E (TMX) = T (SPECIALS) = X	13	A	5	2-5,5	2	5,5	6,5	1,5	5,5
	16	A	5	2,5-6,9	2,5	6,9	8	2	9
	20	A	5	2,5 - 11	2,5	11	12	2	11
	25	A	5	2,5-16,3	2,5	16,3	17,5	2	16
	32	A	5	2,5 - 20,5	2,5	20,5	21,5	2	20
	40	A	5	2,5 - 27	2,5	27	28	2	27

ØD and length "L" : Others dimensions on request. Height H applied by default others dimensions on request.

Material	Body
A = [X155CrVMo.12.1]	58 - 62 HRc

+ Other materials on request.
Other cutting shapes (E ; T ; X) : page 81
Available coatings : page 90
Technical options : page 86

To order :

Die HWS Ball-lock Counterbore Blank D.body L H	Blank
DA - BLCB - 20 - 32 - 5	
Die HWS Ball-lock Counterbore Oblong D.body L H Shape dimensions Position	Shaped
DA - BLC L - 20 - 32 - 5 - P8.2 - W5.2 - T90	

Fastening of key located dies button :

DIE BUTTON D_-SCC_

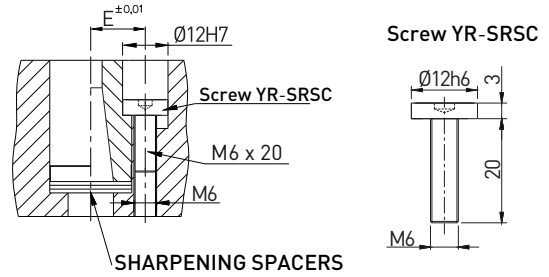
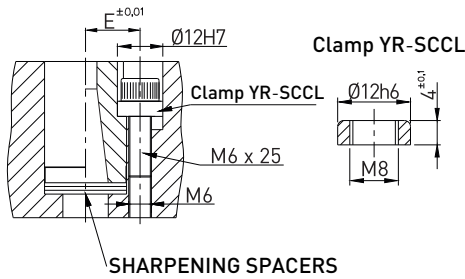

DIE BUTTON D_-SR_

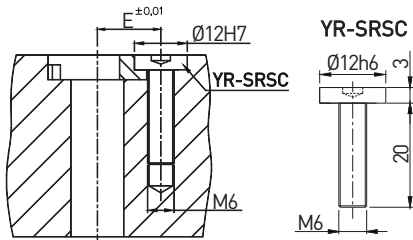

DIE BUTTON D_-SR_

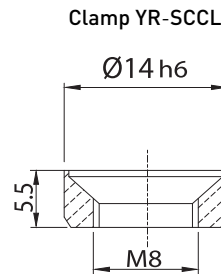

Fastened by screw M6 (FHC)
M8 screw extraction
Not supplied

Fitting of tapered head punches :

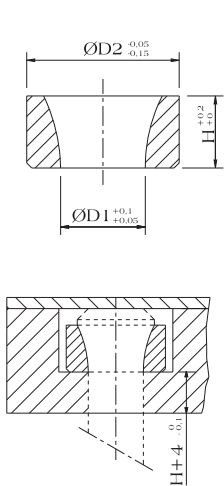

Seat for tapered head punches.

Reference	Ø D1	Ø D2	H
	5	12	6
	6	13	7
	8	16	8
	10	20	9
	13	25	9
	16	32	9
	20	32	10

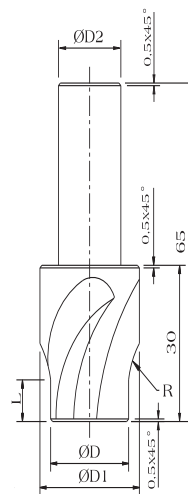

Machining tool for the housing of tapered head punches
Material : High speed = B
Material : Carbure = C

Reference	Ø Df7	Ø D1	Ø D2	R	L
Material	5	7,4	8	10	5
	6	9,5	8	10	5
	8	11,5	8	12	5
	10	14,5	10	15	8
	13	17,5	10	15	8
	16	20,5	10	15	8
	20	25,5	16	15	8

Punch retainers for tapered head punches are available on request page 72.
Standard tapered head punches page 46
Others dimensions on request

To order :

Qty = 15 ; for punches ØD = 10 mm
15 YR-RFSE-10

To order :

Qty = 1 ; ØD = 10 mm in high speed steel
1 YB-RFMT-10

FOR HEADLESS DIE BUTTON
D_-SMC_/D_-SMC_/DA-SCC_
YF-SACB series

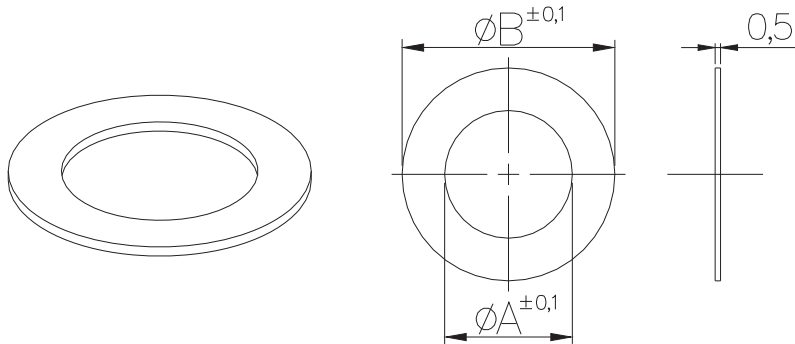

To order :

Qty = 3 ; for die button ØD = 20 mm
3 YF-SACB-20

Reference	Ø D Die button	Ø A	Ø B
YF-SACB (XC70 (1.1249))	10	6	9,7
	13	8	12,7
	16	10	15,7
	20	12,5	19,7
	25	18	24,7
	32	21,5	31,7
	40	28,5	39,7
	50	37,5	49,7

FOR HEADED DIE BUTTON
D_-HMC_/D_-HHC_
YF-SACA series

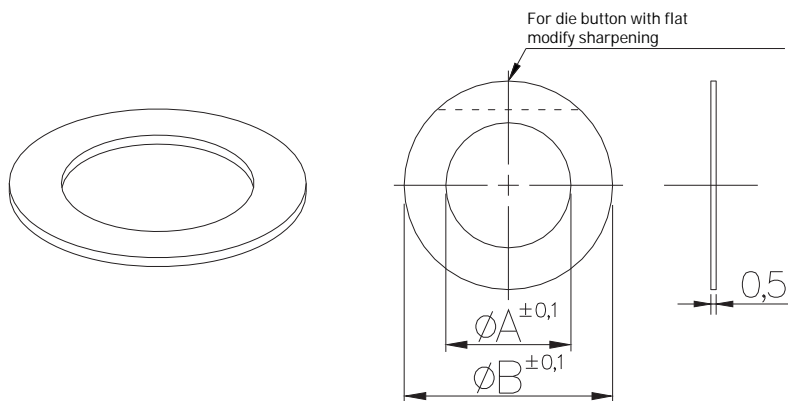

To order :

Qty = 3 ; for die button ØD = 20 mm
3 YF-SACA-20

Reference	Ø D Die button	Ø A	Ø B
YF-SACB (XC70 (1.1249))	10	6,5	13,7
	13	8,5	16,7
	16	10	19,7
	20	12,5	23,7
	25	18	38,7
	32	21,5	35,7
	40	28,5	43,7
	50	37,5	53,7

French patent
REF.1.454.836



Available material
Polyuréthane 90 Shore

To order :

Qty = 2 ; for die button ØD = 16 mm x L = 45mm
3 YU-SSCR-16-45

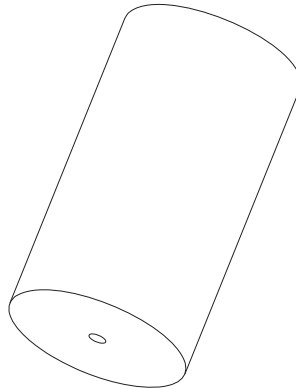

YU-SSCR series

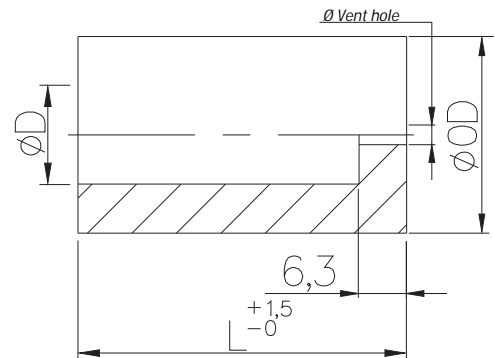

Reference	Ø D (mm)	Ø OD (mm)	L (mm)	Ø Vent hole	Approx stripping pressure (in daN) with distortion of :		
					3mm	6,5mm	9,5mm
* YU-SSCR-5-55	5	18	35	1,6	125	200	
			45		115	175	
			55		105	150	
* YU-SSCR-6-65	6	19	35	1,6	140	240	
			45		135	230	
			55		110	190	240
			65		90	130	200
* YU-SSCR-8-75	8	21	35	1,6	160	250	
			45		150	225	
			55		135	200	300
			65		120	185	290
* YU-SSCR-10-75	10	23	75	2,5	100	165	270
			35		210	350	
			38		190	310	
			45		175	285	
			47		160	270	
* YU-SSCR-13-75	13	26	55	3	145	250	325
			65		130	220	290
			75		115	190	265
			35		260	390	
			38		225	360	
			45		215	340	
* YU-SSCR-16-75	16	30	47	3	165	270	
			55		150	240	300
			65		130	200	250
			75		105	160	200
			35		300	460	
			38		260	420	
* YU-SSCR-20-75	20	38	45	3	240	390	
			47		235	385	
			55		220	360	460
			65		200	330	420
			75		170	290	360
			38		280	420	
* YU-SSCR-25-75	25	50	47	3	240	390	
			55		200	350	550
			65		165	300	450
			75		150	270	400
			35		1200	1800	
			38		1100	1600	
* YU-SSCR-25-75	25	50	45	3	1000	1500	
			47		900	1400	
			55		700	1150	1650
			65		600	1000	1450
			75		500	850	1300

*Intermediate length L



RR-PPTS

For round shaped punches

RR-PPTF

For shaped punches

Ø D	C ±0,10	
	RR-PPTS	RR-PPTF
8	12	10
10	14	12,3
13	17	15
16	20	18
20	25	22,5
25	30	27,8
32	37	34

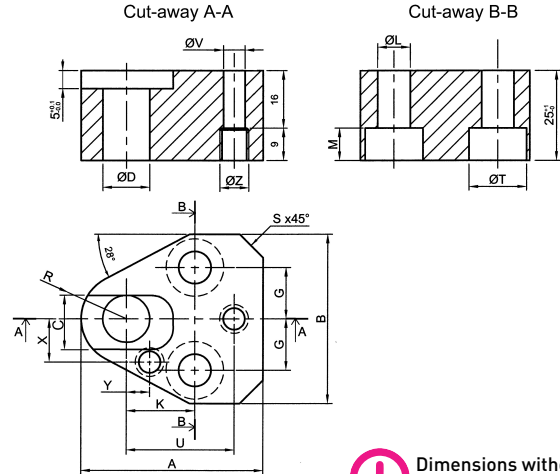
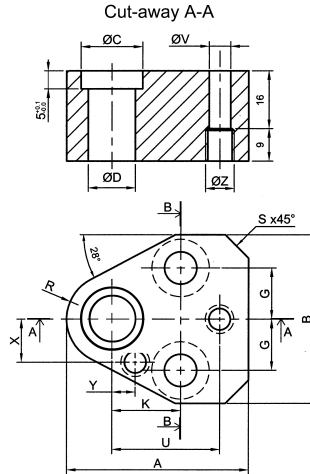

! Dimensions without tolerance ±0,25 mm.

Reference	ØD	A	B	R	S	G	K	Y	U	X	V	L	T	M	Z
	G6	±0,25	±0,25	±0,25	±0,25	±0,10	±0,10	±0,01	±0,01	±0,01	G6	H12	H13	±0,25	
Serie RR-PPTS F	8	44,3	41	9,5	5	11,12	19,05	7,5	26,92	9	6	9	16	9	M8
	10	44,3	41	9,5	5	11,12	19,05	7,5	26,92	9	6	9	16	9	M8
	13	50,4	47	12,5	7,5	14,27	19,05	6,5	29,97	12	6	9	16	9	M8
	16	53,5	50	14	8,5	15,87	19,05	6	31,75	13,5	6	9	16	9	M8
	20	60,1	55	17,4	10	17,47	19,05	5	33,53	16,5	6	11	18	11	M8
	25	69,7	63	22	12	19,84	23,82	7	40,64	22	6	14	20	13	M8
	32	69,7	63	22	12	19,84	23,82	7	40,64	22	6	14	20	13	M8

To order :

Punch retainers without shock plate

Qty = 3 RR-PPT

Shock plate :

ØD (punch)	H=4,8	H=5,8
	8	RR-BPTT-8-4,8
10	RR-BPTT-10-4,8	RR-BPTT-10-5,8
13	RR-BPTT-13-4,8	RR-BPTT-13-5,8
16	RR-BPTT-16-4,8	RR-BPTT-16-5,8
20	RR-BPTT-20-4,8	RR-BPTT-20-5,8
25	RR-BPTT-25-4,8	RR-BPTT-25-5,8
32	RR-BPTT-32-4,8	RR-BPTT-32-5,8

Material	Hardness
Punch retainer	43 - 48 HRc
Shock plate {40CrMo8 T4 / 4140T}	32 - 38 HRc

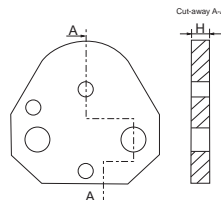

To order :

Shock plate

Qty = 3 RR-BPTT-16-4.8



RR-PPVS

For round shaped punches

RR-PPVF

For shaped punches

Ø D	Ø C RR-PPVS	C RR-PPVF
8	12	10
10	14,5	12,3
13	18,5	15,8
16	20,5	18,3
20	25,5	22,8
25	30,5	27,8
32	38,5	35,3

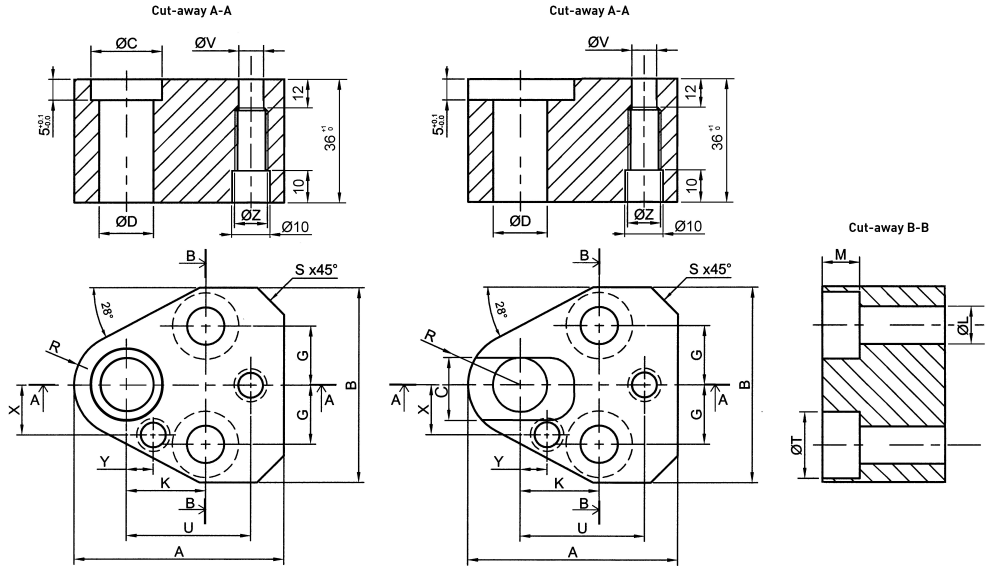

Reference	ØD	A	B	R	S	G	K	Y	U ±0,01	X ±0,01	V Ø6	L	T	M	a°
Serie RR-PPVS F	8	44,3	41	9,5	5	11,12	19,05	7,5	26,92	9	6	9	16	9	30
	10	44,3	41	9,5	5	11,12	19,05	7,5	26,92	9	6	9	16	9	30
	13	50,4	47	12,5	7,5	14,27	19,05	6,5	29,97	12	6	9	16	9	28
	16	53,5	50	14	8,5	15,87	19,05	6	31,75	13,5	6	9	16	9	28
	20	60,1	55	17,5	10	17,47	19,05	5	33,53	16,5	6	11	18	11	28
	25	69,7	63	22	12	19,84	23,82	7	40,64	22	6	14	20	13	28
	32	69,7	63	22	12	19,84	23,82	7	40,64	22	6	14	20	13	28

To order :

Punch retainers without shock plate

Qty = 3 RR-PPVS-20

Shock plate :

ØD (punch)	H=4,8	H=5,8
8	RR-BPTT-8-4,8	RR-BPTT-8-5,8
10	RR-BPTT-10-4,8	RR-BPTT-10-5,8
13	RR-BPTT-13-4,8	RR-BPTT-13-5,8
16	RR-BPTT-16-4,8	RR-BPTT-16-5,8
20	RR-BPTT-20-4,8	RR-BPTT-20-5,8
25	RR-BPTT-25-4,8	RR-BPTT-25-5,8
32	RR-BPTT-32-4,8	RR-BPTT-32-5,8

Material	Hardness
Punch retainer	43 - 48 HRc
Shock plate {40CrMo8 T4 / 4140T}	32 - 38 HRc

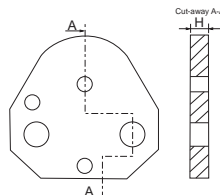

To order :

Shock plate

Qty = 3 RR-BPTT-16-4.8

NEW

RR-PTHS

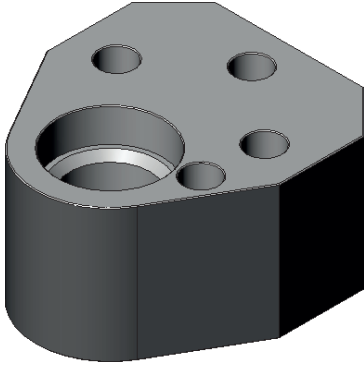

RR-PTHS

For round shaped punches

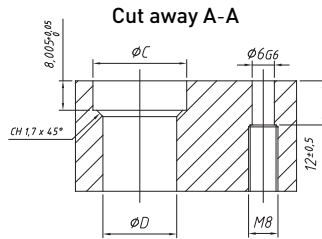

RR-PTHF

For shaped punches

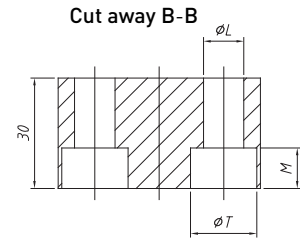

RR-PTHF

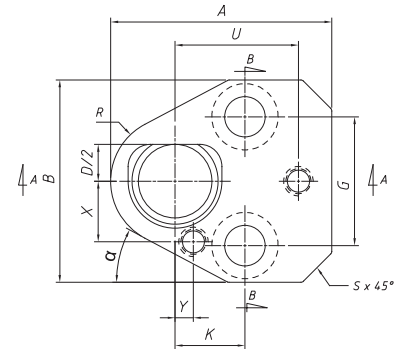
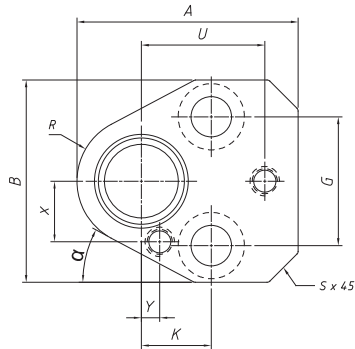

Reference	ØD	C	A	B	R	S	G	K	Y	U	X	L	T	M	a°
	G6	±0,10	±0,25	±0,25	±0,25	±0,25	±0,10	±0,10	±0,01	±0,01	±0,01	H12	H13	±0,25	
Serie RR-PTHS F	10	15,5	44,5	43,7	9,5	12	22,2	19	7,5	26,92	9	9	14,5	9	30
	13	18,5	50,8	50	12,7	15,2	28,6	19	6,5	29,97	12	9	14,5	9	28
	16	21,5	54	53,2	14,3	16,8	31,8	19	6	31,75	13,5	9	14,5	9	28
	20	25,5	60,3	59,5	17,5	20	35	19	5	33,53	16,5	11	18,5	11	28
	25	30,5	69,9	69,1	22,2	24,7	39,6	23,8	7	40,64	22	14	16,5	13	28

To order :

Punch retainers without shock plate

Qty = 3 RR-PTHS - 20

Shock plate :

ØD (punch)	H=4,8	H=5,8
8	RR-BPHT-8-4,8	RR-BPHT-8-5,8
10	RR-BPHT-10-4,8	RR-BPHT-10-5,8
13	RR-BPHT-13-4,8	RR-BPHT-13-5,8
16	RR-BPHT-16-4,8	RR-BPHT-16-5,8
20	RR-BPHT-20-4,8	RR-BPHT-20-5,8
25	RR-BPHT-25-4,8	RR-BPHT-25-5,8
32	RR-BPHT-32-4,8	RR-BPHT-32-5,8

Material	Hardness
Punch retainer	43 - 48 HRc
Shock plate {40CMB8 T4 / 4140T}	32 - 38 HRc

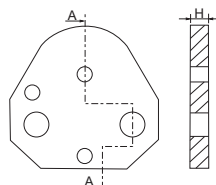

To order :

Shock plate

Qty = 3 RR-BPHT - 16 - 4.8

RR-RFFS

For round shaped punches

Cut away A-A

Cut away B-B

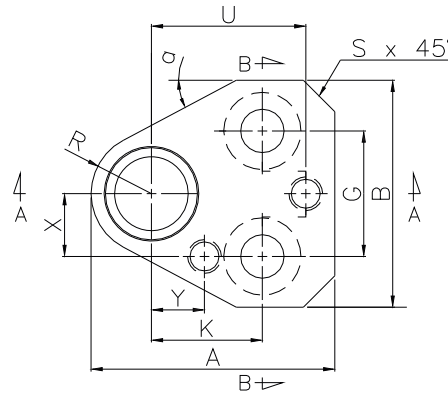
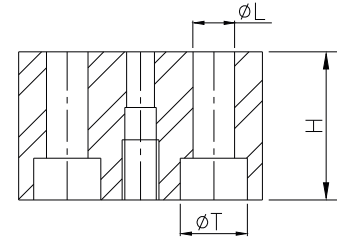
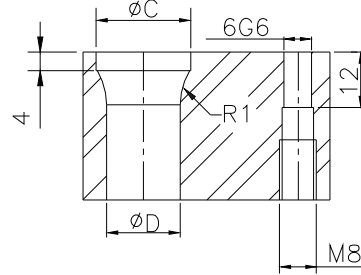
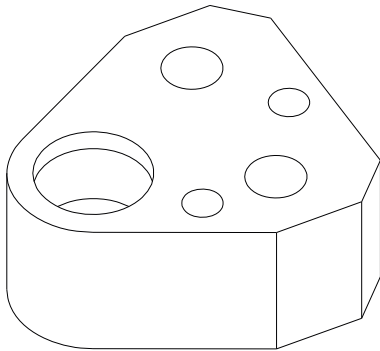

Reference	ϕD K6	C $\pm 0,25$	A $\pm 0,25$	B $\pm 0,25$	H	R $\pm 0,25$	S $\pm 0,25$	G $\pm 0,25$	K $\pm 0,25$	Y $\pm 0,01$	U $\pm 0,01$	X $\pm 0,01$	L H13	T H13	M $\pm 0,25$	a°
RR-RFFS	6	9,5	35	37,5	25	8	5	11,1	19	9	23	8	7	12	9	30
	8	11,5	44,3	41	25	9,5	5	11,12	19,05	7,5	26,92	9	9	16	9	30
	10	14,5	44,3	41	32	9,5	5	11,12	19,05	7,5	26,92	9	9	16	9	30
	13	17,5	50,4	47	32	12,5	7,5	14,27	19,05	6,5	29,97	12	9	16	9	28
	16	20,5	53,5	50	32	14	8,5	15,87	19,05	6	31,75	13,5	9	16	9	28
	20	25,5	60,1	55	41	17,5	10	17,47	19,05	5	33,53	16,5	11	18	11	28
	25	30,5	69,7	63	41	22	12	19,84	23,82	7	40,64	22	14	20	13	28

To order :

Punch retainers without shock plate

Qty = 3 RR - RFFS - 20

Shock plate :

ϕD (punch)	H=4,8	H=5,8
8	RR-BPTT-8-4,8	RR-BPTT-8-5,8
10	RR-BPTT-10-4,8	RR-BPTT-10-5,8
13	RR-BPTT-13-4,8	RR-BPTT-13-5,8
16	RR-BPTT-16-4,8	RR-BPTT-16-5,8
20	RR-BPTT-20-4,8	RR-BPTT-20-5,8
25	RR-BPTT-25-4,8	RR-BPTT-25-5,8
32	RR-BPTT-32-4,8	RR-BPTT-32-5,8

Material	Hardness
Punch retainer	43 - 48 HRc
Shock plate {40CMB8 T4 / 4140T}	32 - 38 HRc

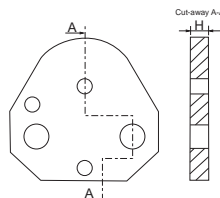

To order :

Shock plate

Qty = 3 RR - BPTT - 16 - 4.8

RR-BLTN

Light duty height = 32mm

RR-BHTN

Heavy duty height = 41mm



Cut away A-A

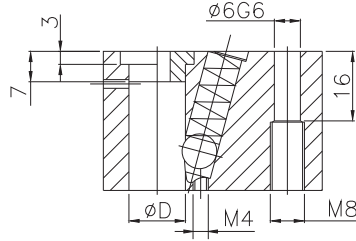

Cut away B-B

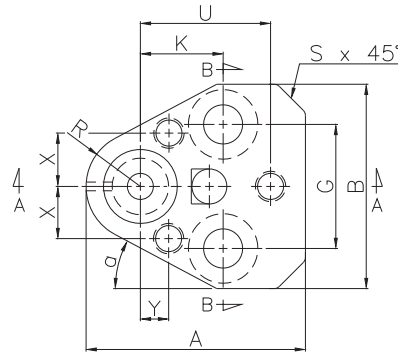
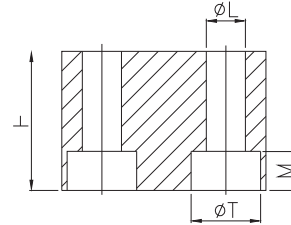

Ball-lock release tool



YZ-BLRT

Ref	ϕD H6	ϕ Ball	A $\pm 0,25$	B $\pm 0,25$	H ^{+1/0}	L ^{+0,3}	U $\pm 0,01$	Y $\pm 0,01$	K $\pm 0,1$	G $\pm 0,2$	X $\pm 0,01$	M $\pm 0,2$	T ^{+0,3}	R $\pm 0,25$	S	a°
LIGHT DUTY																
RR-BLTN	10	8	44,3	41	32	9	26,924	7,5	19,05	22,24	9	9	16	9,5	5	30
	13	8	50,4	47	32	9	29,972	6,5	19,05	28,54	12	9	16	12,5	6,5	28
	16	8	53,5	50	32	9	31,75	6	19,05	31,74	13,5	9	16	14,5	7	28
	20	8	60,1	55	32	11	33,528	5	19,05	34,94	16,5	11	18	17,4	8	28
	25	8	69,7	63	32	14	40,64	7	23,82	39,68	22	13	20	22,2	9	28
HEAVY DUTY																
RR-BHTN	10	10	44,3	41	41	9	26,924	7,5	19,05	22,24	9	9	15	9,5	5	30
	13	12	50,4	47	41	9	29,972	6,5	19,05	28,54	12	9	15	12,5	6,5	28
	16	12	53,5	50	41	9	31,75	6	19,05	31,74	13,5	9	15	14,5	7	28
	20	12	60,1	55	41	11	33,528	5	19,05	34,94	16,5	11	18	17,4	8	28
	25	12	69,7	63	41	14	40,64	7	23,82	39,68	22	13	20	22,2	9	28
	32	12	69,7	63	41	14	40,64	7	23,82	39,68	22	13	20	22,2	9	28
	40	12	76,4	73	41	14	43,993	10	27	48	26	13	20	26	10	28

Material	Hardness
Punch retainer 40CrMo8 T4 / 4140T	43 - 48 HRc

To order :

Punch retainers without shock plate

Qty = 3 RR-BLTN-16

RT-BLSN



Cut-away A-A

Cut-away B-B

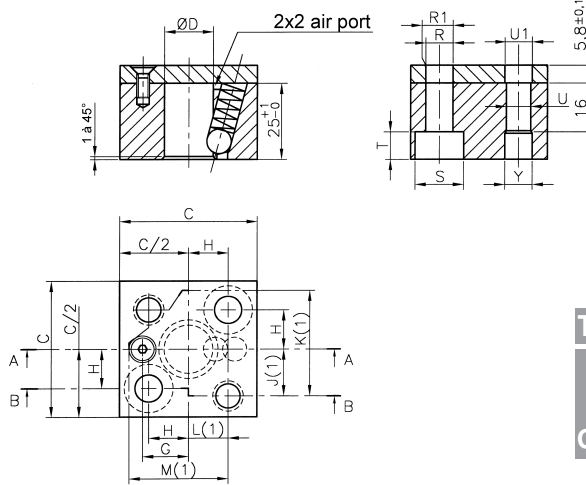

! Shock plate included

To order :

Qty = 3 RT-BLSN-20

Ref.	ØD H6	C ±0,25	G ±0,1	H ±0,1	J ±0,01	K ±0,01	L ±0,01	M ±0,01	R H13	R1 H13	S H13	T ±0,25	U G6	U1 H13	Y H13
RT-BLSN	10	45	15	13	15,5	28,5	13	26	9	9	16	9	8	9	9
	13	45	15	13	15,5	28,5	13	26	9	9	16	9	8	9	9
	16	45	15	13	15,5	28,5	13	26	9	9	16	9	8	9	9
	20	56	19	16	19	35	16	32	11	11	18	11	10	11	11
	25	63	22	20	22,5	42,5	20	40	14	14	20	13	10	11	11

RT-BLRN



Cut-away A-A

Cut-away B-B

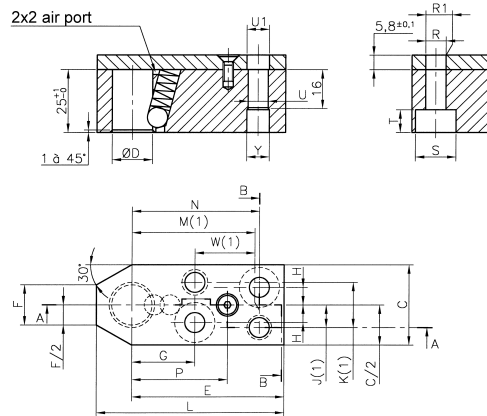

! Shock plate included

To order :

Qty = 3 RT-BLRN-20

Ref.	ØD H6	L ±0,25	C ±0,25	E ±0,2	F ±0,25	G ±0,1	H ±0,1	J ±0,01	K ±0,01	M ±0,01	W ±0,01	N ±0,1	P ±0,1	R H13	R1 H13	S H13	T ±0,25	U G6	U1 H13	Y H13
RT-BLRN	10	75	32	60	18	25	7	9	18	50	25	50	38	9	9	16	9	8	9	9
	13	75	32	60	18	25	7	9	18	50	25	50	38	9	9	16	9	8	9	9
	16	75	32	60	18	25	7	9	18	50	25	50	38	9	9	16	9	8	9	9
	20	85	40	63	20	28	9	11	22	53	25	53	41	11	11	18	11	10	11	11
	25	85	40	63	20	28	9	11	22	53	25	53	41	11	11	18	11	10	11	11

Material	Hardness
Punch retainer	43 - 48 HRc
Shock plate {40CMB8 T4 / 4140T}	32 - 38 HRc

+ Ball-lock release tool for punches removal available page 73

RT-PPTS

For round shaped punches

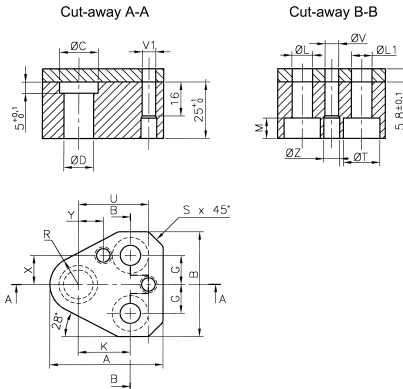

Shock plate included

To order :

Qty = 3 RT-PPTS - 20

Ref.	ØD G6	C ±0,25	A ±0,25	B ±0,25	R ±0,25	S ±0,25	G ±0,25	K ±0,25	Y ±0,01	U ±0,01	X ±0,01	V G6	L H13	T H13	M ±0,25	Z H13
RT-PPTS	8	12	44,5	38	9,5	5	10	21	9	29	10	6	9	16	9	7
	10	14	44,5	38	9,5	5	10	21	9	29	10	6	9	16	9	7
	13	17	50,5	47	12,5	6,5	13	23	11	32	13	6	9	16	9	7
	16	20	53,5	50	14	7	12	26	12	34	13	6	11	18	11	7
	20	25	60	55	17,5	8	14	27	11,5	34	17	8	11	18	11	9
	25	30	69,5	63	22	9	15	30	12	39	21	8	14	20	13	9
32	37	69,5	63	22	9	15	33	16,5	40	22	8	14	20	13	9	

RT-PPTF

For shaped punches

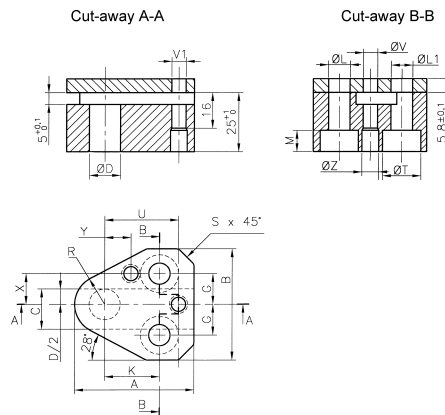

Shock plate included

To order :

Qty = 3 RT-PPTF - 20

Ref.	ØD G6	C ±0,25	A ±0,25	B ±0,25	R ±0,25	S ±0,25	G ±0,25	K ±0,25	Y ±0,01	U ±0,01	X ±0,01	V G6	L H13	T H13	M ±0,25	Z H13
RT-PPTF	8	11	44,5	38	9,5	5	10	21	9	29	10	6	9	16	9	7
	10	12	44,5	38	9,5	5	10	21	9	29	10	6	9	16	9	7
	13	17	50,5	47	12,5	6,5	13	23	11	32	13	6	9	16	9	7
	16	18,5	53,5	50	14	7	12	26	12	34	13	6	11	18	11	7
	20	23	60	55	17,5	8	14	27	11,5	34	17	8	11	18	11	9
	25	28,5	69,5	63	22	9	15	30	12	39	21	8	14	20	13	9
32	35	69,5	63	22	9	15	33	16,5	40	22	8	14	20	13	9	

Material	Hardness
Punch retainer	43 - 48 HRc
Shock plate { _{40CMB8 T4 / 4140T} }	32 - 38 HRc

RT-PPSS

For round shaped punches

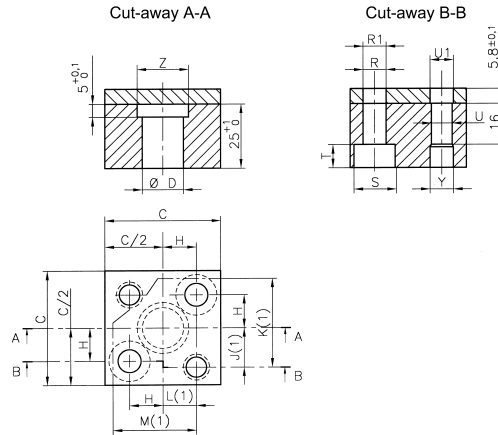

Shock plate included

To order :

Qty = 3 RT-PPSS - 20

Reference	ØD	C	H	J	K	L	M	R	R1	S	T	U	U1	Y	Z
	G6	±0,25	±0,1	±0,01	±0,01	±0,01	±0,01	H13	H13	H13	±0,25	G6	H13	H13	±0,25
RT-PPSS	8	45	13	15,5	28,5	13	26	9	9	16	9	8	9	9	12
	10	45	13	15,5	28,5	13	26	9	9	16	9	8	9	9	14
	13	45	13	15,5	28,5	13	26	9	9	16	9	8	9	9	17
	16	45	13	15,5	28,5	13	26	9	9	16	9	8	9	9	20
	20	56	16	19	35	16	32	11	11	18	11	10	11	11	25
	25	63	20	22,5	42,5	20	40	14	14	20	13	10	11	11	30
	32	75	25	28	53	25	50	14	14	20	13	10	11	11	37

RT-PPSF

For shaped punches

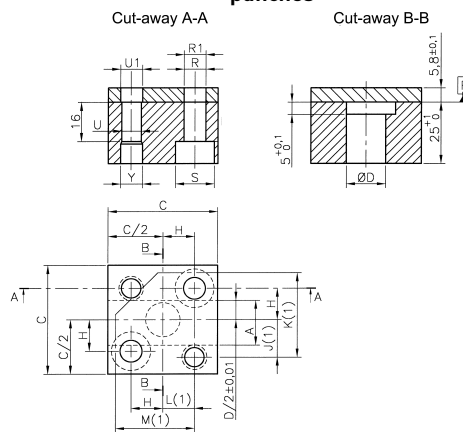

Shock plate included

To order :

Qty = 3 RT-PPSF - 20

Ref.	ØD	A	C	H	J	K	L	M	R	R1	S	T	U	U1	Y	Z
	G6	±0,25	±0,25	±0,01	±0,01	±0,01	±0,01	±0,01	H13	H13	H13	±0,25	G6	H13	H13	±0,25
RT-PPSF	8	11	45	13	15,5	28,5	13	26	9	9	16	9	8	9	9	12
	10	12	45	13	15,5	28,5	13	26	9	9	16	9	8	9	9	14
	13	17	45	13	15,5	28,5	13	26	9	9	16	9	8	9	9	17
	16	18,5	45	13	15,5	28,5	13	26	9	9	16	9	8	9	9	20
	20	23	56	16	19	35	16	32	11	11	18	11	10	11	11	25
	25	28,5	63	20	22,5	42,5	20	40	14	14	20	13	10	11	11	30
	32	35	75	25	28	53	25	50	14	14	20	13	10	11	11	37

Material	Hardness
Punch retainer	43 - 48 HRc
Shock plate {40CMDB T4 / 4140T}	32 - 38 HRc

RT-PPRS

For round shaped punches

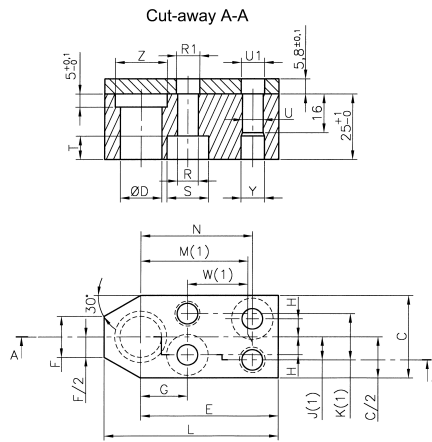

! Shock plate included

To order :

Qty = 3 RT-PPRS - 20

Ref.	ØD	L	C	E	F	G	H	J	K	M	W	N	R	R1	S	T	U	U1	Y	Z
	G6	±0,25	±0,25	±0,2	±0,25	±0,01	±0,1	±0,01	±0,01	±0,01	±0,01	±0,01	H13	H13	H13	±0,25	G6	H13	H13	±0,25
RT-PPRS	8	60	32	50	11	15	7	9	18	40	25	40	9	9	16	9	8	9	9	12
	10	60	32	50	11	15	7	9	18	40	25	40	9	9	16	9	8	9	9	14
	13	67	32	53	16	18	7	9	18	43	25	43	9	9	16	9	8	9	9	17
	16	67	32	53	16	18	7	9	18	43	25	43	9	9	16	9	8	9	9	20
	20	80	40	60	22	25	9	11	22	50	25	50	11	11	18	11	10	11	11	25
	25	80	40	60	22	25	9	11	22	50	25	50	11	11	18	11	10	11	11	30
	32	95	50	70	30	28	13	15	30	58	30	58	14	14	20	13	10	11	11	37

RT-PPRF

For shaped punches

Cut-away A-A

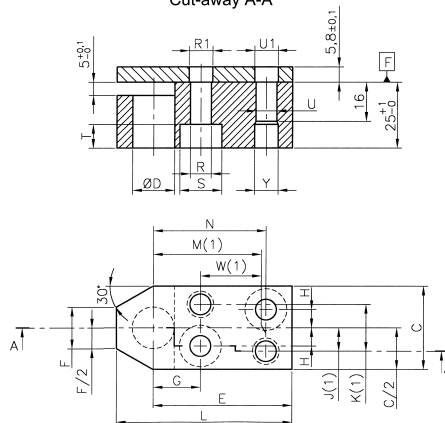

! Shock plate included

To order :

Qty = 3 RT-PPRF - 20

Ref.	ØD	L	C	E	F	G	H	J	K	M	W	N	R	R1	S	T	U	U1	Y	Z
	G6	±0,25	±0,25	±0,2	±0,25	±0,01	±0,1	±0,01	±0,01	±0,01	±0,01	±0,01	H13	H13	H13	±0,25	G6	H13	H13	±0,25
RT-PPRF	8	60	32	50	11	15	7	9	18	40	25	40	9	9	16	9	8	9	9	12
	10	60	32	50	11	15	7	9	18	40	25	40	9	9	16	9	8	9	9	14
	13	67	32	53	16	18	7	9	18	43	25	43	9	9	16	9	8	9	9	17
	16	67	32	53	16	18	7	9	18	43	25	43	9	9	16	9	8	9	9	20
	20	80	40	60	22	25	9	11	22	50	25	50	11	11	18	11	10	11	11	25
	25	80	40	60	22	25	9	11	22	50	25	50	11	11	18	11	10	11	11	30
	32	95	50	70	30	28	13	15	30	58	30	58	14	14	20	13	10	11	11	37

Material	Hardness
Punch retainer	43 - 48 HRc
Shock plate {40CMDB T4 / 4140T}	32 - 38 HRc

RZ-PPPH For shaped punches

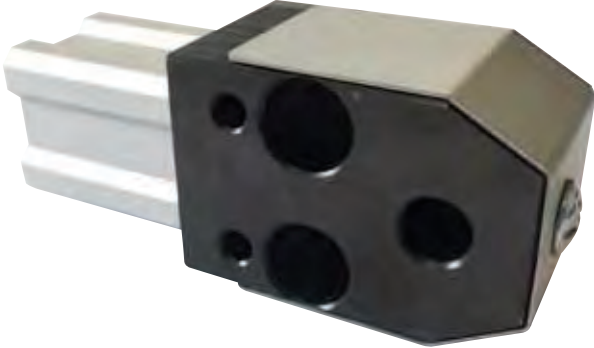

Retractable pneumatically controlled punch retainers are used when parts for different modes are manufactured on the same tool. A blade holds the punch in position and sets it back sufficiently to prevent contact with the material. The layout of the holes on the part can be changed in a few minutes or even seconds. A blade holds the punch in position and sets it back sufficiently to prevent contact with the material.

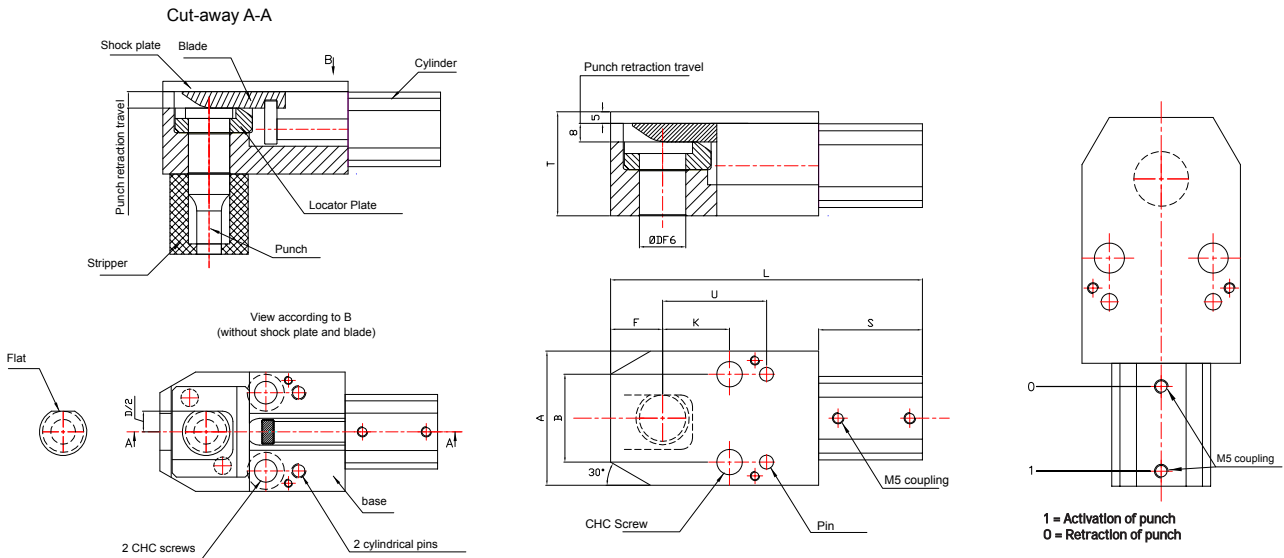

+ Retractable pneumatically controlled punch retainers can be used with P_PPN and P_PPE type punches (pages 42-43). If fitted with a stripper, make your choice according to the standard on page 68.

! Connection to the compressed air system : You must drill holes in the frame and discharge vents in the press. The pipes must be fixed to the bottom of the frame by clamps. Diameter of connection to cylinder : M5. Accessories required for connection to the compressed air system are not supplied. A flat location must be done on round shaped punches to allow the fitting in the orientation plate.

Reference	ØD	L	A	B	F	C	K	S	T	U	CHC screw	Pin
RZ-PPPH	10	117	46	30	17,5	72,5	25	44,5	45	41	M8x50	GT 6x32
	13	117	49	30	17,5	72,5	25	44,5	45	41	M10x50	GT 6x32
	16	117	49	30	17,5	72,5	25	44,5	45	41	M10x50	GT 6x32
	20	139,5	58	30	22,5	90	29	49,5	45	45	M10x50	GT 6x32
	25	139,5	58	38	22,5	90	29	49,5	45	45	M10x50	GT 6x32
	32	190,5	80	56	31	121	38	69,5	55	60	M12x60	GT 8x32
	40	190,5	80	56	31	121	38	69,5	55	60	M12x60	GT 8x32

To order :

Qty = 2 R Z - P P P H - 20

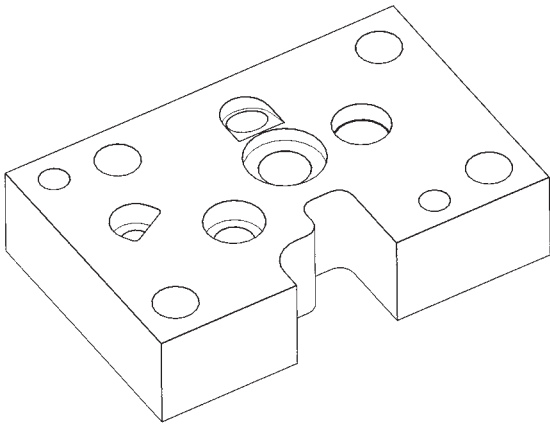

Cut away A-A

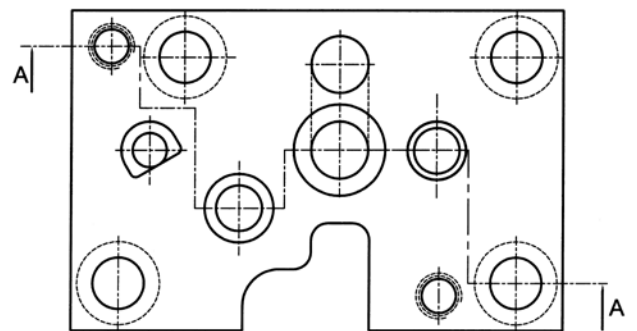
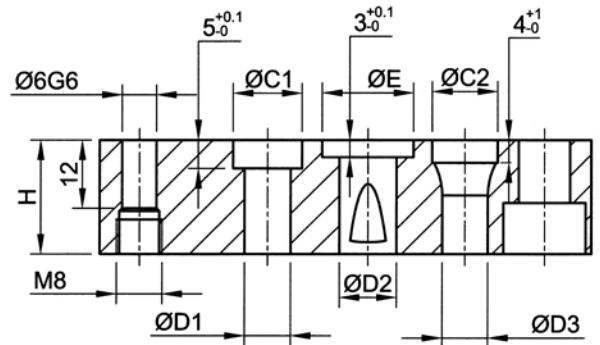

Dimensioning recommendations :

- Please use preferably the standard dimensions as specified in the below table. Other specifications are possible on request.
- The punch retainer positioning is carried out by ØG6 pin holes with a M8 thread for punch retainer.
- Shock plate can also be made according to special drawing.
- Specify the ball-lock punches preferences when ordering.
- For quotation, please send us the drawing of the requested punch retainer (DWG, STEP etc...).

Ball location (top view)

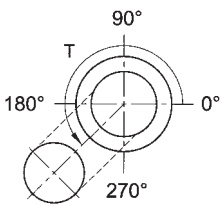

Antirotation position shaped punches with cylindrical head, conical head or tapered punches (top view)

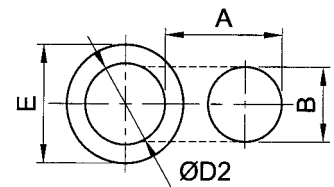
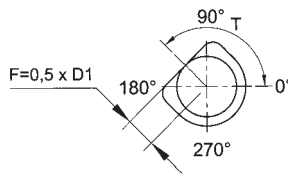

Headed punches			Ball-lock punches for light duty				Ball-lock punches for heavy duty				Tapered head punches				
ØD1	ØC1	H (recommended)	ØD2	ØE	H (recommended)	A	B	ØD2	ØE	H (recommended)	A	B	ØD3	ØC2	H (recommended)
5	9	25/32													
6	10	25/32											6	9,5	25
7	11	25/32											8	11,5	25
8	12	25/32											10	14,5	32
9	13	25/32													
10	14	25/32	10	14	32	14	10	10	14	41	16	12	10	14,5	32
11	15	25/32													
12	16	25/32													
13	17	25/32	13	17	32	14	10	13	17	41	18	14	13	17,5	32
14	18	25/32													
15	19	25/32													
16	20	25/32	16	20	32	14	10	16	20	41	18	14	16	20,5	32
20	25	25/32	20	25	32	14	10	20	25	41	18	14	20	25,5	41
25	30	25/32	25	30	32	14	10	25	30	41	18	14			
32	37	25/32						32	37	41	18	14			
40								40	45	41	18	14			

Material	Hardness
SAE 4140	43 - 48 HRc

To order :

Qty = 2 R R - X X X X - 10 - 14 - 25

SQUARE FOR DIES BUTTONS

RR-BLSN

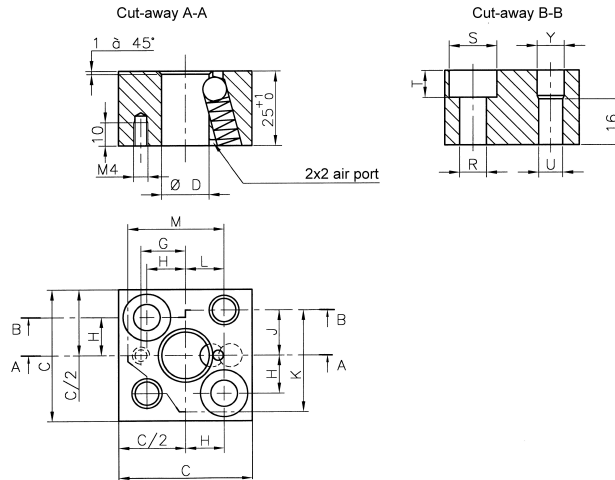

To order :

Die retainers without shock plate

Qty = 3 RR - BLSN - 20

Ref.	ØD H6	C ±0,25	G ±0,1	H ±0,1	J ±0,01	K ±0,01	L ±0,01	M ±0,01	R H13	S H13	T ±0,01	U ±0,25	Y H13
RR-BLSN	10	45	15	13	15,5	28,5	13	26	9	16	9	8	9
	13	45	15	13	15,5	28,5	13	26	9	16	9	8	9
	16	45	15	13	15,5	28,5	13	26	9	16	9	8	9
	20	56	19	16	19	35	16	32	11	18	11	10	11
	25	63	22	20	22,5	42,5	20	40	14	20	13	10	11
	32	63	22	20	22,5	42,5	20	40	14	20	13	10	11
	40	71	27	25	27,5	52,5	25	50	14	20	13	10	11

RR-BLRN

RECTANGULAR FOR DIES BUTTONS

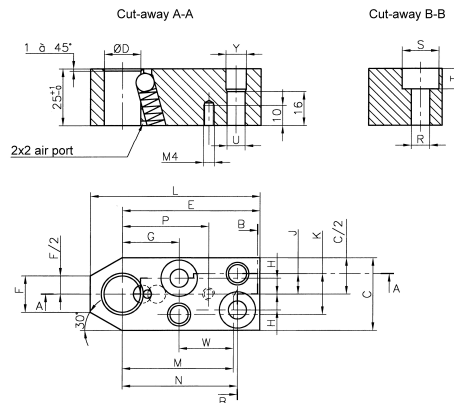

To order :

Die retainers without shock plate

Qty = 3 RR - BLRN - 20

Ref.	E H6	L ±0,25	C ±0,25	E ±0,2	F ±0,25	G ±0,1	H ±0,1	J ±0,01	K ±0,01	M ±0,01	W ±0,01	N ±0,1	P ±0,1	R H13	S H13	T ±0,25	U G6	Y H13
RR-BLSN	10	75	32	60	18	25	7	9	18	50	25	50	38	9	16	9	8	9
	13	75	32	60	18	25	7	9	18	50	25	50	38	9	16	9	8	9
	16	75	32	60	18	25	7	9	18	50	25	50	38	9	16	9	8	9
	20	85	40	63	20	28	9	11	22	53	25	53	41	11	18	11	10	11
	25	85	40	63	20	28	9	11	22	53	25	53	41	11	18	11	10	11
	32	100	56	72	24	30	14	17	34	55	25	55	43	11	18	11	10	11

Material	Hardness
SAE 4140	43 - 48 HRc



Ball-lock release tool for punches removal available page 73
Dimensions without tolerance ±0,25 mm.

MADE FROM STANDARDISED PUNCHES AND DIES



Shapes and dimensions to be precised as per table on page 82

We are also at your disposal to produce punches and dies according to your drawing.
Price and lead times on request.

Comment 1:

- 1 Mln. radius of 0.2mm can be done on the punch
- 2 Mln. radius of 0.2mm can be done on the die

Comment 2:
Punch and die reading direction according to the drawing below.

Comment 3:
To ensure correct operation between punch and die, do not forget to specify the clearance J per face.

Order example 1

Ball-lock punch :
TMX64 type PB-BLNT
Ø13 mm - length L1 = 71mm - material B
P=8.63 - W=4.13 - L2=16mm - T90°

Ball-lock die :
TMX64 type DA-BLCT
Ø16 mm - height 32mm -
Working length 5mm
P=8.69 - W=4.19 - T90°

Standard orientation of the ball indentation is 90° as shown opposite. Other orientation on request.

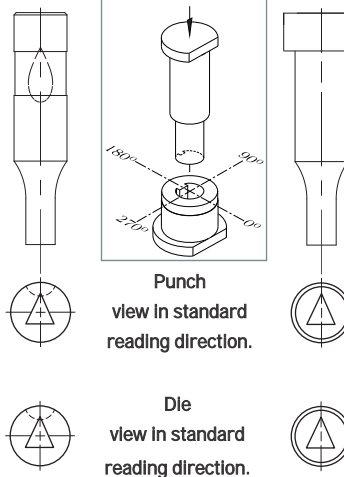

Order example 2

Headed punch :
TMX64 type PB-PPNT
Ø10 mm - length L1 = 80mm - material B
P=7.52 - W=3.56 - L2=13mm - T0°

Headed die :
TMX64 type DA-HHCT
Ø16 mm - height 32mm -
Working length 5mm
P=7.62 - W=3.66 - T0°

Standard flat location is at T = 0° as shown opposite. Other location on request.

TMX type - Convex shape

90°

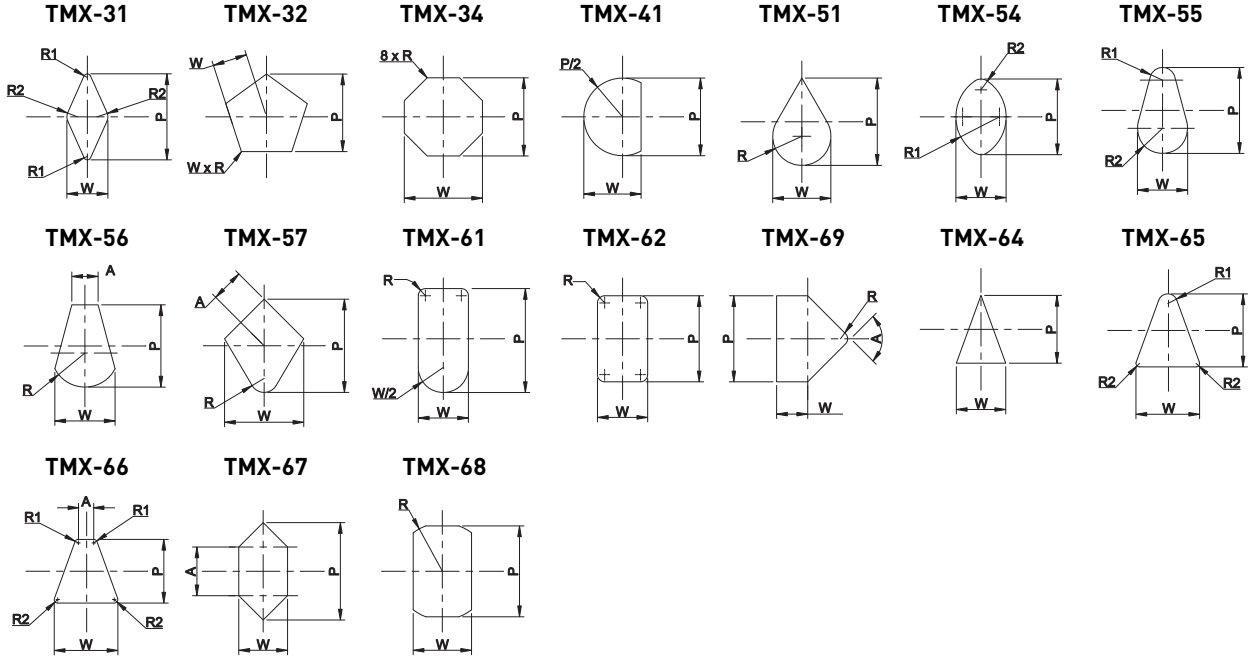

180°

0°

TMX type - Convex shape

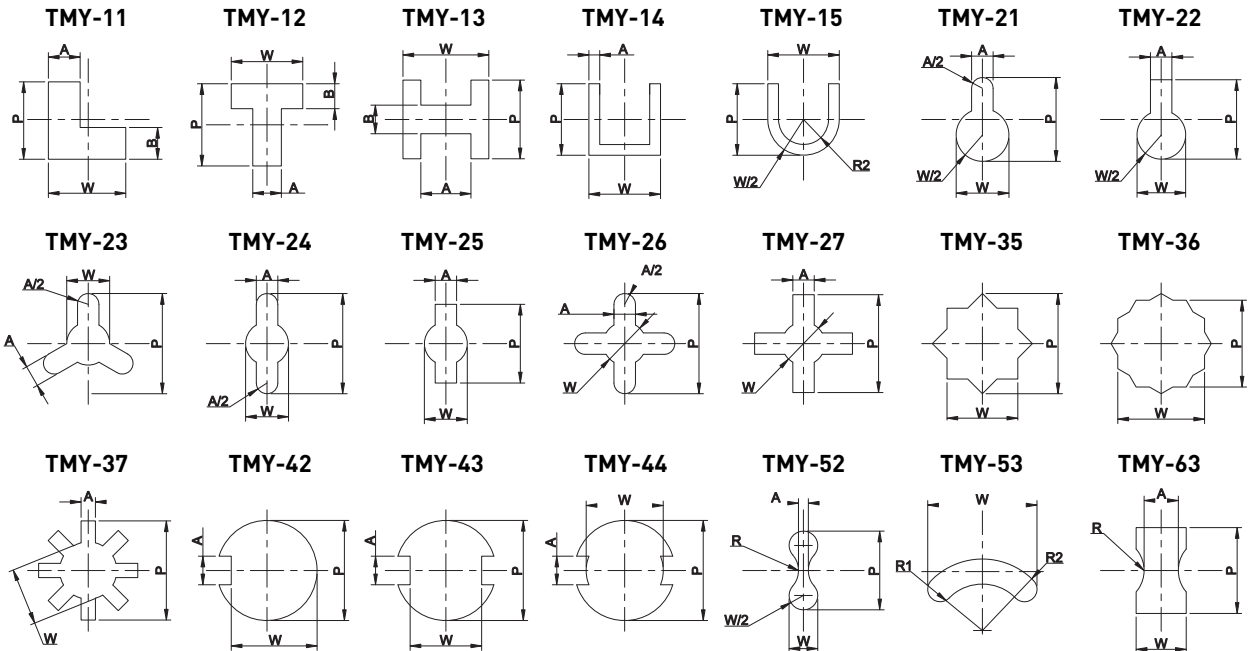

270°

Punch flat location page 83
Die flat location page 86

Views of the head side for punches and cutting face for dies.

To order :

Punch H55 ISO 80/20 Solid TMX shape D body L1 L2 Shape dimensions Flat Position Shaped
PB - PPNT - 16 - 71 - 20 - P9.2 - W5.2 - R2 - T90 - TMX64

Shapes
(TMY) = E
(TMX) = T
(SPECIALS) = X

FLAT LOCATION:

Tangent flat

Double tangent flat

Through flat (a)

Double through flat

Special flat (b)

R2

R2 (2x)

R84

R84 (2x)

R89

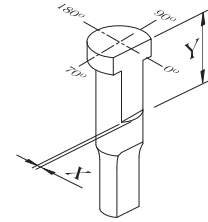
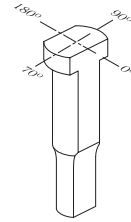
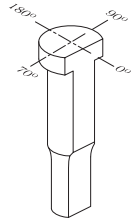
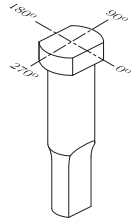
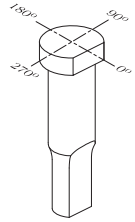

(a) Specify depth by X =

(b) Specify depth by X = and length by Y =

To order :

Qty = 2

PB-PPNR-16-71-20-P7.2-W6.2-R2-T0

DOWEL LOCATION:

HEADED PUNCHES

Code Ø P

R0 P = 3

R4 P = 3

R41 P = 4

R43 P = 6

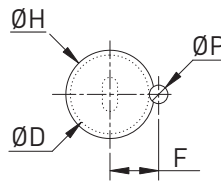
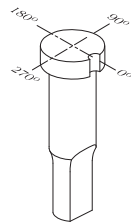

$$F = 0,5 * D + 0,5 * P$$

Ø D = Ø Body

Ø P = Ø Dowel pins

Ø H = Ø Head

ØP (dowel pins) tangent to ØD (body).

To order :

Qty = 2

PB-PPNR-16-71-20-P7.2-W6.2-R0-T0

OPTIMIZATION :

	Code
Polishing the cutting part	TP
Chamfering of cutting edges Manual chamfering R0,1 to R0,3	TR
Vent hole removal (For ejector punches)	GA

Cutting part relief

PT

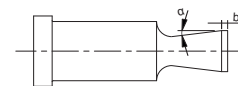

PB-PPNL-16-71-20-P9-W7-PT2-3

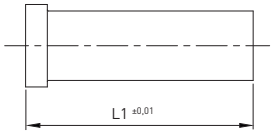
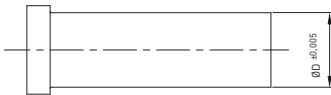
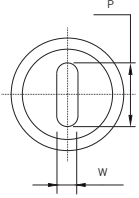

2° relief with 3mm straight section

TOLERANCE MODIFICATIONS

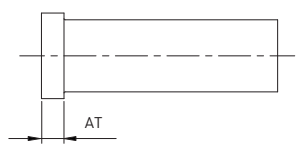
Type Code	Length L1	Body diameter	P and W shape dimensions
	AL	AD	AP_
Drawings			
Example	PB-PPNA-16-71-AL Tolerance $\pm 0,01$ on length L1	PB-PPNA-16-71-AD Tolerance $\pm 0,005$ on body diameter	PB-PPNL-16-71-20-P9-W7-AP1 AP1 : tol. $\pm 0,005$ on P and W AP2 : tol. $\pm 0,001/0$ on P and W AP3 : tol. $0/0,01$ on P and W

Type Code	Head thickness
	AT_
Drawings	
Example	PB-PPNA-16-71-AT2
Type	AT1 $\pm 0,01$ Tolerance $\pm 0,01$ on head thickness AT2 $\pm 0/-0,05$ Tolerance $\pm 0/-0,05$ on head thickness

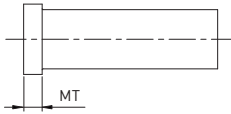
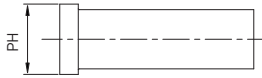
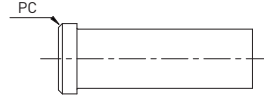
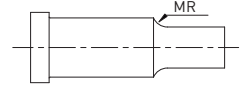
DIMENSIONAL MODIFICATIONS

Type	Head thickness	Head diameter	Head chamfering	Connecting radius
Code	MT	PH	PC	MR
Drawings				
Example	PB-PPNB-16-71-MT4	PB-PPNA-16-71-PH18	PB-PPNA-16-71-PC0,5-45	PB-PPNS-20-80-19-P17-MR2
	 <p>Regaining the thickness head by grinding the upper surface result in a reduction of the length L1</p>	Head diameter reduction at 18mm (19mm in standard)	(CH 0,5 x 45°)	(Radius R = 2 instead of 10 +3/0 in standard.)

SHEAR ANGLES

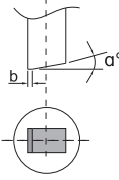
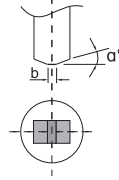
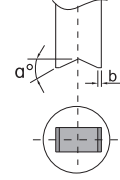
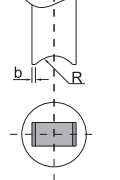
Type	ROUNDS + SHAPES			
	1 shear	2 shears	2 negativ shears	Radius
Code	KS	KF	KY	KR
Drawings				
Example	KS2-0.5 Shear a=2° with flat b=0.5mm	KF3-1 2 Shears a=3° with flat b=1mm	KY5-1 2 Shears a=5° with flat b=1mm	KR15-1 Radius R15 with flat b=0.5mm

 The shear is made in the direction of the dimensions P for the shear angles KS, KF, KY and KR.

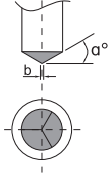
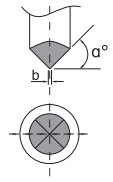
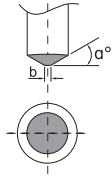
Type	ROUNDS ONLY		
	3 shears	4 shears	Conical
Code	KM	KN	KC
Drawings			
Example	KM5-0 3 Shears a=5° without flat	KN2-0 4 Shears a=2° without flat	KC30-3 Cone a=2° with flat b=3MM

FLAT LOCATION:

Headed dies

Tangent flat

R2

Double tangent flat

R2 (2x)

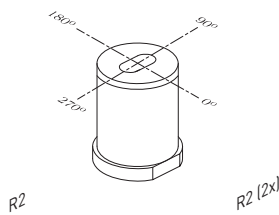

Straight dies

5mm x 1.5mm flat

R2

14mm height flat

R20 - R80

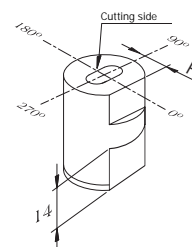
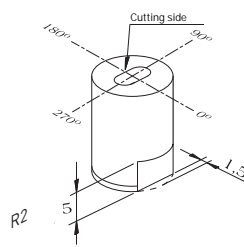

R80 = Cutting side
R20 = Flat at the bottom

Ø Body	06	08	10	13	16	20	22	25	32	38
F	2,6	3,5	4	5,5	7	8,5	9,5	11	14	17
Ø Body	40	45	50	56	63	71	76	85	90	100
F	18	20,5	23	26	29,5	33,5	35,5	40	42,5	47,5

To order :

Qty = 1

DB-SMCR-20-32-8-P8-W4-R2-T90

ALL TYPES OF DIES

R84

Through flat

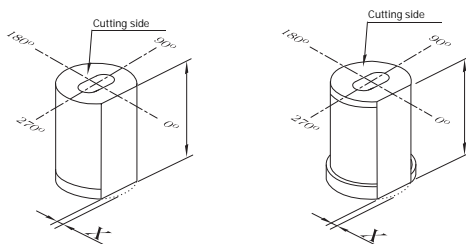

X = Flat depth based on the body Ø

R89

Special flat (b)

(b) Precise depth by X = length by Y =

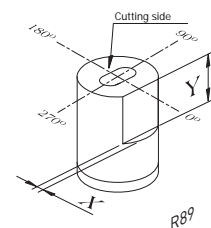

To order :

Qty = 1

DA-SMDL-16-25-5-P9-W6-R89X1.2Y15-T0

DOWEL LOCATION:

Headed dies

Code	Ø P
R0	P = 3
R4	P = 3
R41	P = 4
R43	P = 6

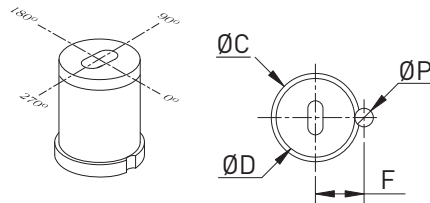

$$F = 0,5 * D + 0,5 * P$$

- Ø D = Ø Body
- Ø P = Ø Dowel pins
- Ø H = Ø Head



ØP (dowel pins) tangent to ØD (body).

To order :

Qty = 2

DA-HMDL-16-25-5-P9-W6-R0-T0

Straight dies

Code	Ø P	Ø 6	Ø 8	Ø 10	Ø 13	Ø 16 - 25	Ø 32 - 100
R0	P = 3	F=0,5*D	F=0,5*D	F=0,5*D	F=0,5*D	F=0,5*D	F=0,5*D
R4	P = 3	F=3,9	F=4,7	F=5,5	F=6,7	F=0,5*D	F=0,5*D
R41	P = 4	F=4,4	F=5,2	F=6,0	F=7,2	F=0,5*D	F=0,5*D
R43	P = 6	F=5,4	F=6,2	F=7,0	F=8,2	F=0,5*D+1,0	F=0,5*D

Ø D = Ø Body

Ø P = Ø Dowel pins

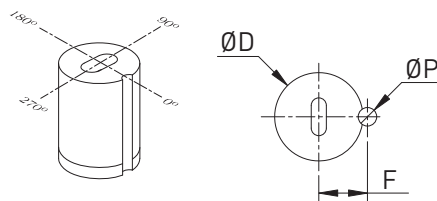

To order :

Qty = 3

DA-SMDL-16-25-5-P9-W6-R4-T0

WASTE RETENTION:

Waste retention | GX

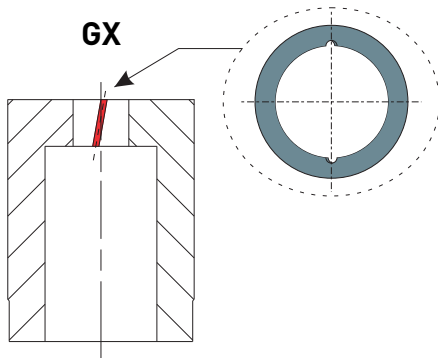

Principle : Thin grooves are machined at opposite angles into the cutting shape.

This generates small protuberances in the waste which hold it in the die.



Others options can be recommended on request to prevent the rising from the waste.

TOLERANCE MODIFICATIONS

Type Code	Length L1	Body diameter	P and W shape dimensions
	AL	AD	AP_
Drawings			
Example	DA-HMCA-20-25-5-AL Tolerance $\pm 0,01$ on length L1	DA-HMCS-20-32-8-AD Tolerance $\pm 0,005$ on body diameter	DB-HMCL-32-32-8-P16-W8-AP AP1 : tol. $\pm 0,005$ on P and W AP2 : tol. $\pm 0,001/0$ on P and W AP3 : tol. $0/0,01$ on P and W

DIMENSIONAL MODIFICATIONS

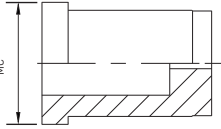
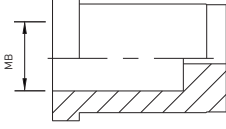
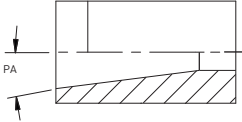
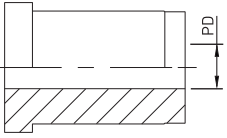
Type	Collar diameter reductions	Relief diameter	Tapered relief angle	Straight relief on the length
Code	MC	MB	PA	PD
Drawings				
Example	DB-HMCA-20-25-5-MC22 Collar Ø22	DA-HMCA-20-32-5-MB15 Relief Ø15	DA-HMDS-16-25-5-P6,3-PA2 Relief angle 2°	DA-HMDS-20-25-25-P8,2-PD

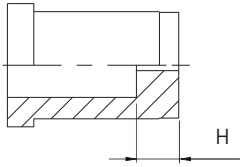
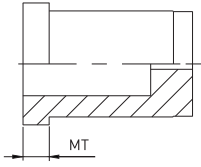
Type	Working height	Collar thickness reduction
Code		MT
Drawings		
Example	DA-HMCA-20-25-4 Height H changed to H = 4mm	DA-HMCA-20-25-5-MT4



Head thickness reduction by grinding of the upper side resulting in a reduction in length L1

COATINGS :

The standard coatings proposed are shown in the table below.

Coating	TiN	TiCN	CrN	AlCrN	t - ac
Microhardness (HV0,05)	2300	3000	1750	3200	5000
Thickness (micrometer)	2 to 4	2 to 4	2 to 4	2 to 4	1,5 to 3
Color	Yellow gold	Blue grey	Silver grey	Blue grey	Black
Applications	Cutting steel with low mechanical properties	Stainless steel cutting	Cutting copper alloys	High yield strength steel cutting	Cutting aluminium and composites



Other coatings available on request.

Note : The coatings can significantly improve the cutting process. Do not hesitate to ask us.

CUTTING CLEARANCE :

Materials	Tight clearance	Medium clearance	Recommended clearance	Large clearance
Aluminium	1 - 2%	4 - 8%	12 - 15%	16 - 20%
Stainless steel	2 - 4%	6 - 10%	18 - 22%	25 - 27%
Mild steel	2 - 4%	10 - 14%	16 - 20%	15 - 23%
High yield strength steel	5 - 10%	22 - 25%	26 - 32%	33 - 36%

*Diameter clearance value

RECOMMANDATIONS

- The function of the cutted shape is an important info to define the clearance value between the punch and the die.
- If no precision is required, the lifespan of the punches and dies can be significantly increased by using a large clearance.
- If precise profil specifications and a sheared height greater than 50% of the sheet thickness are required, a tight clearance between the punch and the die is recommended.
- A precise alignment between the punch and die is essential to ensure a precise cutting and the lifespan of the tools.
- The dimensions of the cutted shape is defined by the punch, the dimensions of the waste (slug) by the die.
- In the case of "recommended clearance" or "large clearance", it may be recommended to use ejector punches.

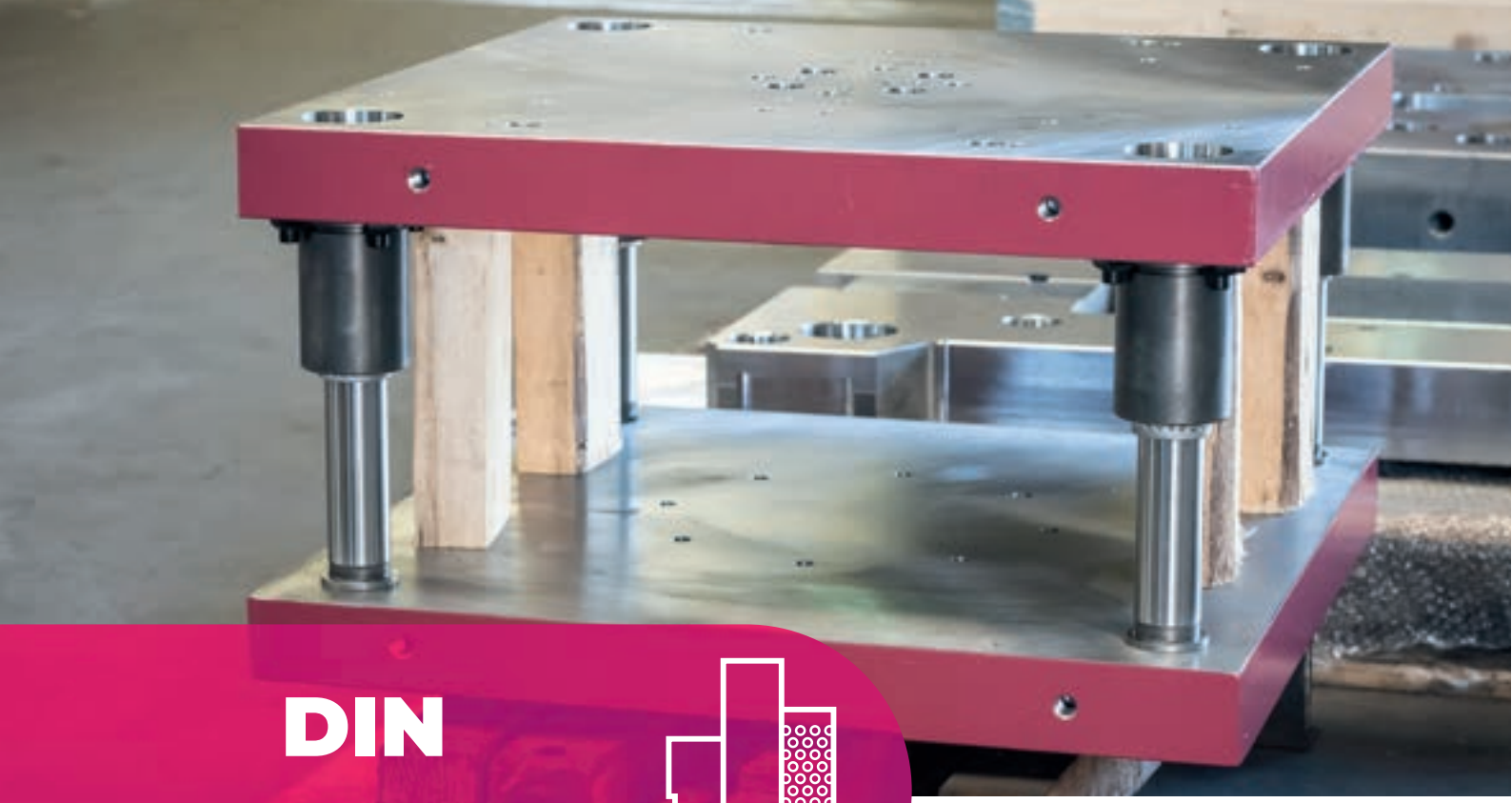



**DIN
STANDARD**



Guiding elements

MDL® **BLUEline**

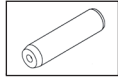
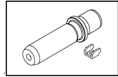
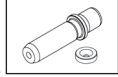
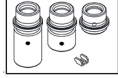

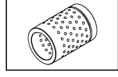
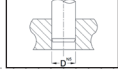
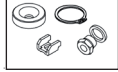
■ Compatibility to DIN standard and Easyfit		95
■ Straight column DP10		96
■ Demountable column with clip fastening DP21		97
■ Demountable column with central fastening DP22		98
■ Steel / bronze-plated demountable bushing DB11 DB21		99 - 100
■ Demountable flanged bushing DB31		101
■ Bushing with steel ball bearings DB41		103 - 104
■ Ball cage DC13		105
■ Installation instructions		107 - 108
■ Accessories		109

Both our standard MDL guiding components and the DIN-compatible MDL Blue Line products are equipped with our Easyfit system.

DIN COMPATIBILITY

All components in the Blue Line range are compatible and interchangeable with guiding elements complying with the DIN Standard.

See Equivalence Table below:

MDL Blue Line part	DIN compatibility
Straight column DP10	DIN 9825
Demountable column DP21 / DP 22	DIN 9825
Demountable bushing DB11 / DB21	DIN 9831
Demountable flanged bushing DB31	DIN 9831
Ball bearing guide bushing DB41	DIN 9831
Ball cage DC13	DIN 5401

EASYFIT SYSTEM

for columns

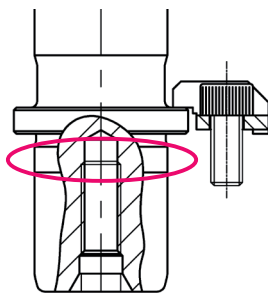

for bushings

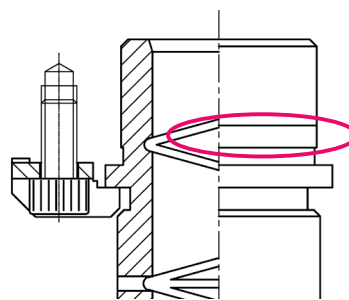

The EasyFit system allows easier assembly and disassembly of columns and/or bushings while ensuring parts are perfectly perpendicular to the plate surface.

Tightening is achieved using a shoulder over a height of 5mm under the flange. Positioning is then ensured by the perpendicularity of the adjusted flange.

Our Easyfit design has been successfully used for more than 30 years by our clients worldwide over our whole MDL product portfolio. It is now compliant with DIN Standard and allows part interchangeability.

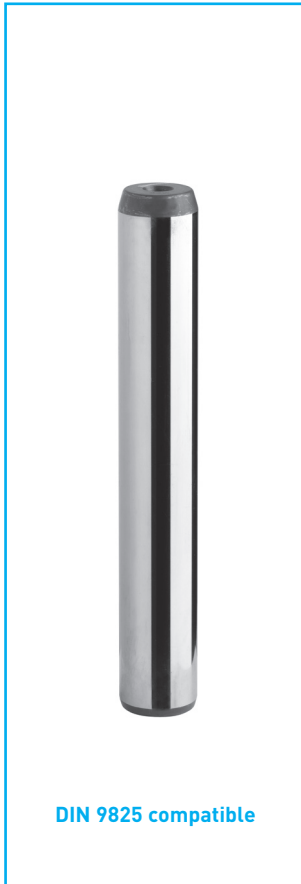

DIN 9825 compatible

Example

Column D1=30 - L=160
Please indicate :
DP10.030.160

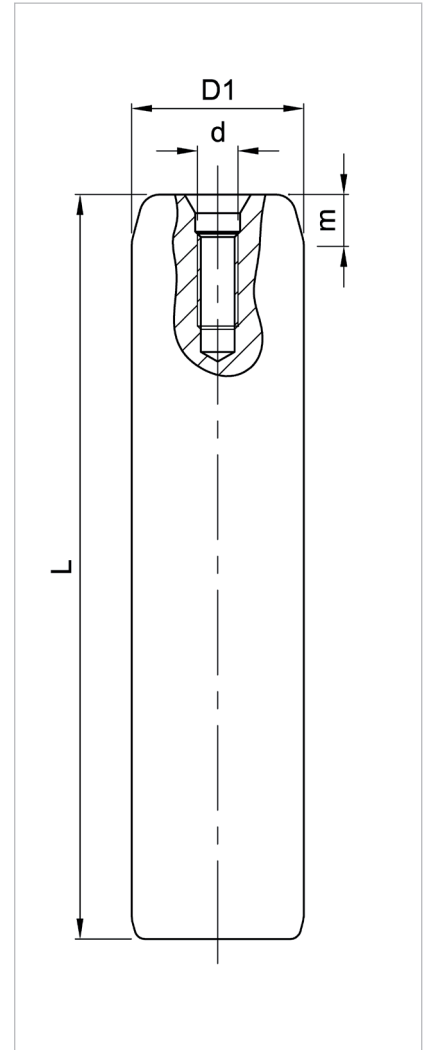
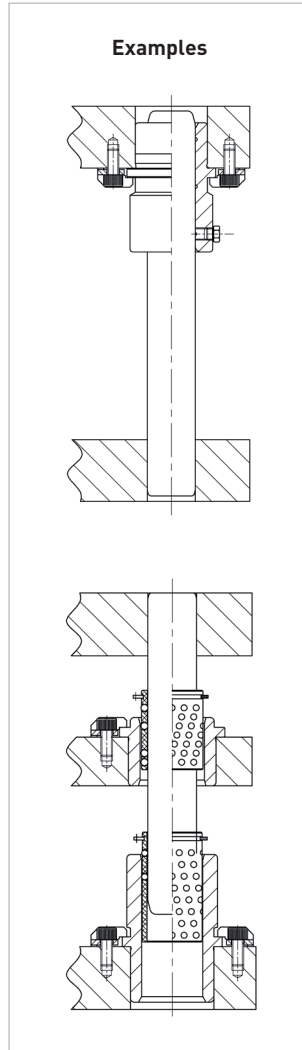
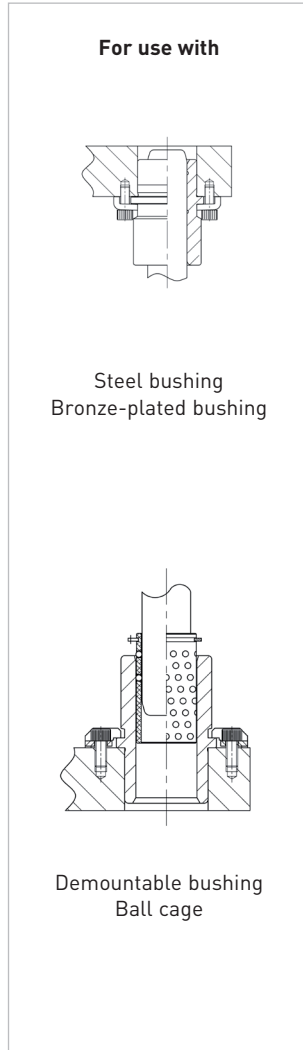

Tempered case-hardened steel columns with a hardness of 60-64HRC, with Easyfit system.

D ₁ h4	19	20	24	25	30	32	40	50	63	80
d	M8		M8		M8		M8	M8	M8	M8
m	4		6		6		6	8	8	8
L	REFERENCE									
100	DP10.019.100	DP10.020.100	DP10.024.100	DP10.025.100						
112	DP10.019.112	DP10.020.112	DP10.024.112	DP10.025.112						
125	DP10.019.125	DP10.020.125	DP10.024.125	DP10.025.125	DP10.030.125	DP10.032.125				
140	DP10.019.140	DP10.020.140	DP10.024.140	DP10.025.140	DP10.030.140	DP10.032.140				
160	DP10.019.160	DP10.020.160	DP10.024.160	DP10.025.160	DP10.030.160	DP10.032.160	DP10.040.160			
180	DP10.019.180	DP10.020.180	DP10.024.180	DP10.025.180	DP10.030.180	DP10.032.180	DP10.040.180	DP10.050.180		
200	DP10.019.200	DP10.020.200	DP10.024.200	DP10.025.200	DP10.030.200	DP10.032.200	DP10.040.200	DP10.050.200		
224	DP10.019.224	DP10.020.224	DP10.024.224	DP10.025.224	DP10.030.224	DP10.032.224	DP10.040.224	DP10.050.224		
250			DP10.024.250	DP10.025.250	DP10.030.250	DP10.032.250	DP10.040.250	DP10.050.250	DP10.063.250	
280			DP10.024.280	DP10.025.280	DP10.030.280	DP10.032.280	DP10.040.280	DP10.050.280	DP10.063.280	DP10.080.280
315					DP10.030.315	DP10.032.315	DP10.040.315	DP10.050.315	DP10.063.315	DP10.080.315
355							DP10.040.355	DP10.050.355	DP10.063.355	DP10.080.355
400							DP10.040.400	DP10.050.400	DP10.063.400	DP10.080.400
450								DP10.050.450	DP10.063.450	DP10.080.450
500								DP10.050.500	DP10.063.500	DP10.080.500



DIN 9825 compatible

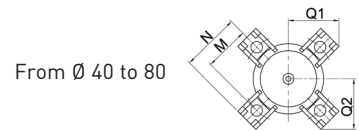
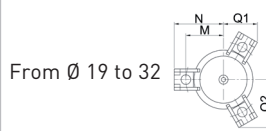
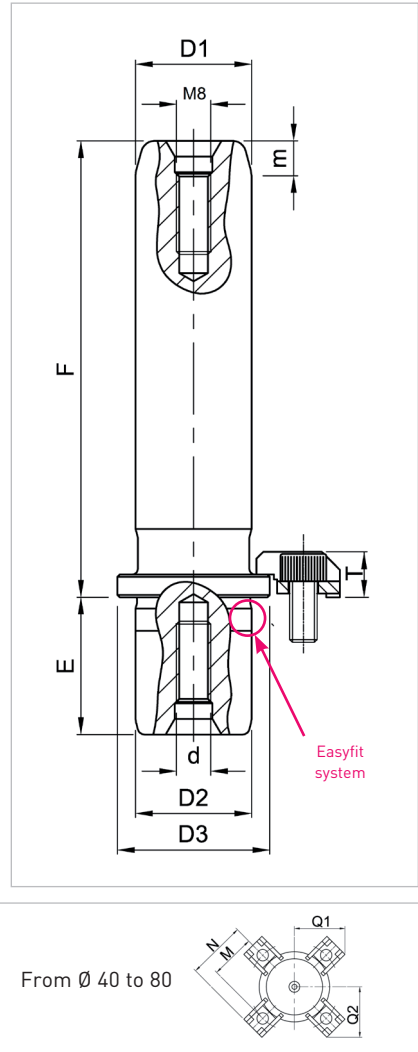
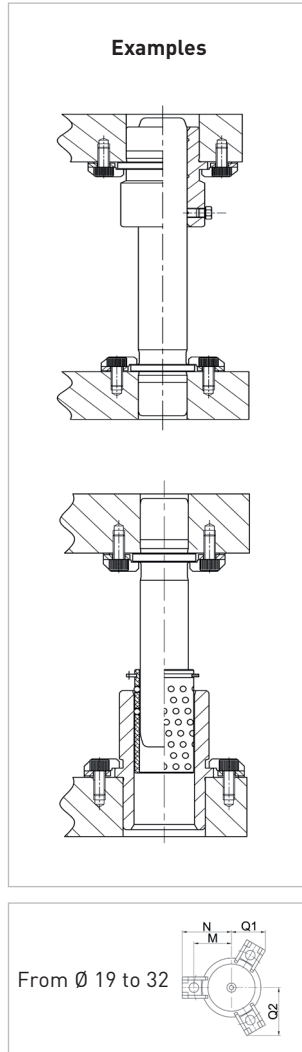
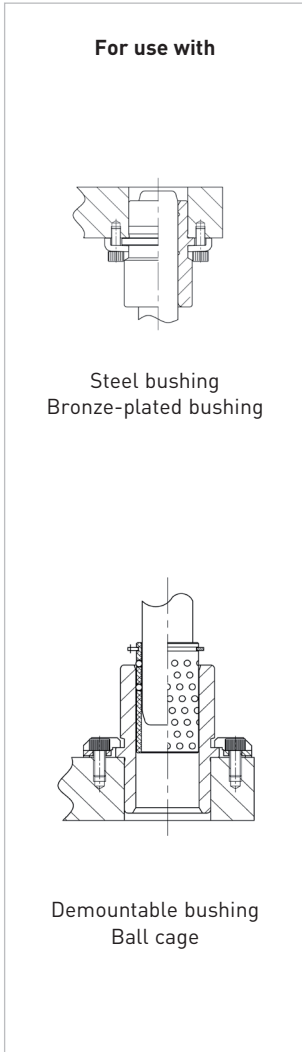

Example
Column D1=30 - F=160
Please state:
DP21.030.160

Tempered case-hardened steel columns with a hardness of 60-64HRC, with Easyfit system. Come with fastening clamp and screws. Quote D1h³ is available upon request.

D ₁ h ⁴ = D ₂ j ⁶	19	20	24	25	30	32	40	50	63	80
D ₃	25		32		40		50	63	76	95
E	20		25		32		40	45	50	60
d	M8		M8		M8		M8	M8	M8	M12
m	6		8		8		8	8	8	8
Qty. clamp	3		3		3		4	4	4	4
Ref. clamp	B02.006.100									
Screw	A05.006.012									
M	18		21,5		25,5		30,5	37	45,5	53
N	25,9		29,4		33,4		38,4	44,9	53,4	60,9
Q1	19,2		21		23		32,3	36,9	43,4	48,2
Q2	26,1		29,1		32,6		32,3	36,9	43,4	48,2
T	10									
F	REFERENCES									
100	DP21.019.100	DP21.020.100	DP21.024.100	DP21.025.100						
112	DP21.019.112	DP21.020.112	DP21.024.112	DP21.025.112	DP21.030.112	DP21.032.112				
125	DP21.019.125	DP21.020.125	DP21.024.125	DP21.025.125	DP21.030.125	DP21.032.125	DP21.040.125			
140	DP21.019.140	DP21.020.140	DP21.024.140	DP21.025.140	DP21.030.140	DP21.032.140	DP21.040.140	DP21.050.140		
160	DP21.019.160	DP21.020.160	DP21.024.160	DP21.025.160	DP21.030.160	DP21.032.160	DP21.040.160	DP21.050.160	DP21.063.160	
180	DP21.019.180	DP21.020.180	DP21.024.180	DP21.025.180	DP21.030.180	DP21.032.180	DP21.040.180	DP21.050.180	DP21.063.180	
200	DP21.019.200	DP21.020.200	DP21.024.200	DP21.025.200	DP21.030.200	DP21.032.200	DP21.040.200	DP21.050.200	DP21.063.200	DP21.080.200
224			DP21.024.224	DP21.025.224	DP21.030.224	DP21.032.224	DP21.040.224	DP21.050.224	DP21.063.224	DP21.080.224
250			DP21.024.250	DP21.025.250	DP21.030.250	DP21.032.250	DP21.040.250	DP21.050.250	DP21.063.250	DP21.080.250
280					DP21.030.280	DP21.032.280	DP21.040.280	DP21.050.280	DP21.063.280	DP21.080.280
315							DP21.040.315	DP21.050.315	DP21.063.315	DP21.080.315
355								DP21.050.355	DP21.063.355	DP21.080.355
400										DP21.080.400



Example
Column D1=30 - F=160
Please state:
DP22.030.160

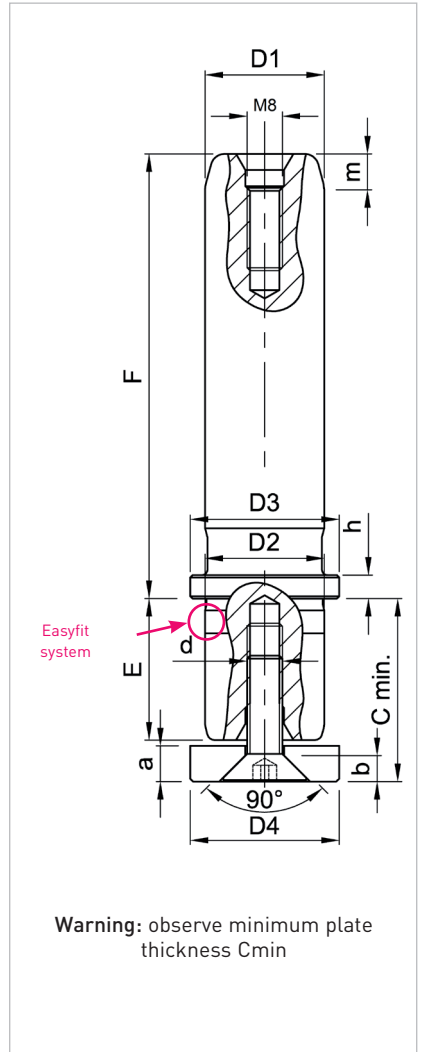
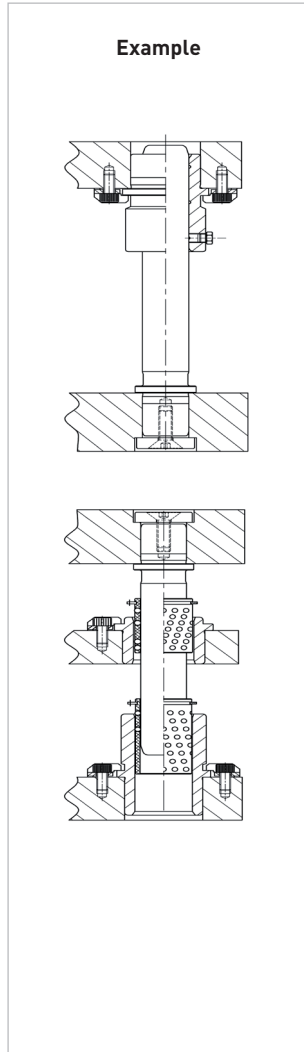
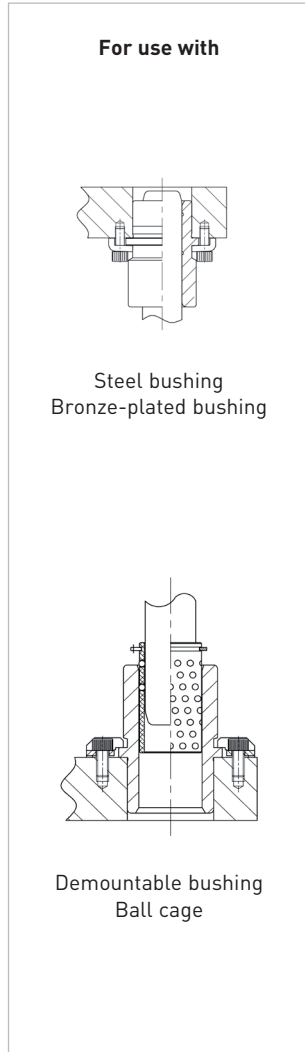

Tempered case-hardened steel columns with a hardness of 60-64HRC, with Easyfit system
Come with washer and screw. Quote $D1h^3$ is available upon request.

D1 h ⁴ = D2 l ⁶	19	20	24	25	30	32	40	50	63	80
D ₃	25		32		40		50	63	80	93
D ₄	25		32		40		50	60	70	93
E	20		25		32		40	45	50	60
d	M8		M8		M8		M8	M8	M8	M12
m	6		8		8		8	8	8	8
a	6		6		6		6	6	6	12
b	4,3		4,3		4,3		4,3	4,3	4,3	6,3
Cmin	26		31		38		46	51	56	72
Washer	P02.020.100		P02.025.100		P02.032.100		P02.040.100	P02.050.100	P02.063.100	P02.080.100
Vis					A09.008.020					A09.012.025
h						6				
F	REFERENCES									
100	DP22.019.100	DP22.020.100	DP22.024.100	DP22.025.100						
112	DP22.019.112	DP22.020.112	DP22.024.112	DP22.025.112	DP22.030.112	DP22.032.112				
125	DP22.019.125	DP22.020.125	DP22.024.125	DP22.025.125	DP22.030.125	DP22.032.125	DP22.040.125			
140	DP22.019.140	DP22.020.140	DP22.024.140	DP22.025.140	DP22.030.140	DP22.032.140	DP22.040.140	DP22.050.140		
160	DP22.019.160	DP22.020.160	DP22.024.160	DP22.025.160	DP22.030.160	DP22.032.160	DP22.040.160	DP22.050.160	DP22.063.160	
180	DP22.019.180	DP22.020.180	DP22.024.180	DP22.025.180	DP22.030.180	DP22.032.180	DP22.040.180	DP22.050.180	DP22.063.180	
200	DP22.019.200	DP22.020.200	DP22.024.200	DP22.025.200	DP22.030.200	DP22.032.200	DP22.040.200	DP22.050.200	DP22.063.200	DP22.080.200
224			DP22.024.224	DP21.025.224	DP22.030.224	DP22.032.224	DP22.040.224	DP22.050.224	DP22.063.224	DP22.080.224
250			DP22.024.250	DP21.025.250	DP22.030.250	DP21.032.250	DP22.040.250	DP22.050.250	DP22.063.250	DP22.080.250
280					DP22.030.280	DP21.032.280	DP22.040.280	DP22.050.280	DP22.063.280	DP22.080.280
315							DP22.040.315	DP22.050.315	DP22.063.315	DP22.080.315
355								DP22.050.355	DP22.063.355	DP22.080.355
400										DP22.080.400



Example
Bushing D1=40 - F=45
Bronze-plated
Please state:
DB21.040.045

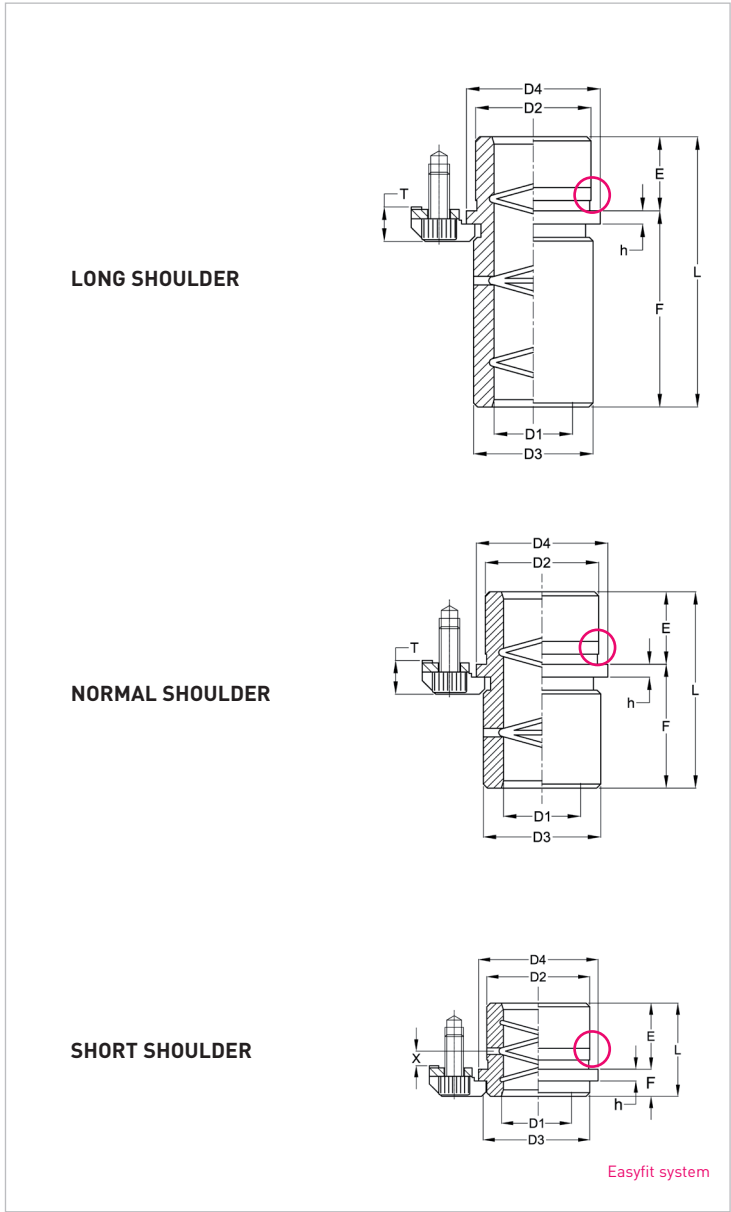
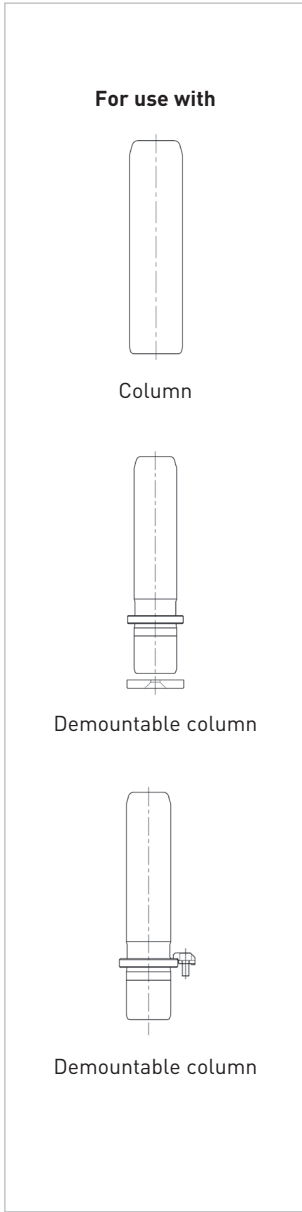

Tempered case-hardened steel bushings with a hardness of 60-64HRC, with Easyfit system, delivered with fastening clamps and screws.
Two different materials are available:
- Steel bushings: DB11 high rigidity and resistance
- Bronze-plated bushings: DB21 technology specific to the MDL group combining the rigidity of steel with the frictional coefficient of bronze

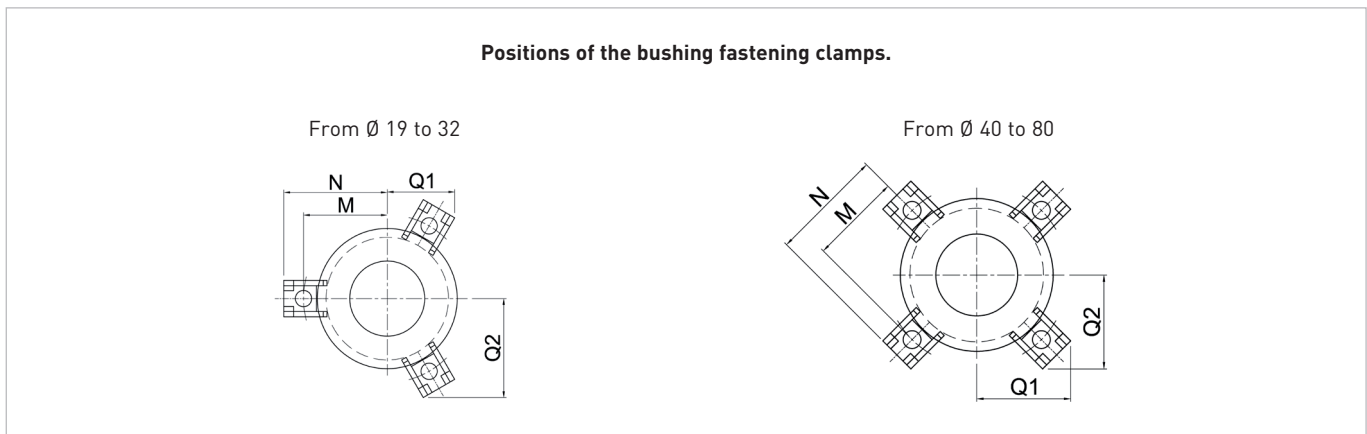

D ₁ H ⁵	19	20	24	25	30	32	40	50	63	80
D ₂	32		40		48		58	70	85	105
D ₃	39		46		53		63	77	92	115
D ₄	40		48		56		66	80	95	118
E	23		23		30		37	47	60	60
Qty. clamps	3		3		3		4	4	4	4
Ref. clamps	B02.006.100									
Vis	A05.006.012									
h	6									
M	26		30		33,5		38,5	45,5	53	64,5
N	33,9		37,9		41,4		46,4	53,4	60,9	72,4
Q1	23,4		25,3		27,1		38	42,9	48,2	56,3
Q2	33,1		36,5		39,6		38	42,9	48,2	56,3
T	10									

LONG SHOULDER

D ₁	19	20	24	25	30	32	40	50	63	80
F	36		56		63		71	80	90	90
L	59		79		93		108	127	150	150
Réf. acier	DB11.019.036	DB11.020.036	DB11.024.056	DB11.025.056	DB11.030.063	DB11.032.063	DB11.040.071	DB11.050.080	DB11.063.090	DB11.080.090
Réf. pl. bronze	DB21.019.036	DB21.020.036	DB21.024.056	DB21.025.056	DB21.030.063	DB21.032.063	DB21.040.071	DB21.050.080	DB21.063.090	DB21.080.090

NORMAL SHOULDER

D ₁	19	20	24	25	30	32	40	50	63	80
F	20		36		45		45	50	56	60
L	43		59		75		82	97	116	120
Réf. acier	DB11.019.020	DB11.020.020	DB11.024.036	DB11.025.036	DB11.030.045	DB11.032.045	DB11.040.045	DB11.050.050	DB11.063.056	DB11.080.060
Réf. pl. bronze	DB21.019.020	DB21.020.020	DB21.024.036	DB21.025.036	DB21.030.045	DB21.032.045	DB21.040.045	DB21.050.050	DB21.063.056	DB21.080.060

SHORT SHOULDER

D ₁	19	20	24	25	30	32	40	50	63	80
D ₃	32		40		48		58	70	85	105
F	12		12		12		15	18	20	20
L	35		35		42		52	65	80	80
Réf. acier	DB11.019.012	DB11.020.012	DB11.024.012	DB11.025.012	DB11.030.012	DB11.032.012	DB11.040.015	DB11.050.018	DB11.063.020	DB11.080.020
Réf. pl. bronze	DB21.019.012	DB21.020.012	DB21.024.012	DB21.025.012	DB21.030.012	DB21.032.012	DB21.040.015	DB21.050.018	DB21.063.020	DB21.080.020



Example
Bushing D1=30 - F=62
Please state:
DB41.030.062

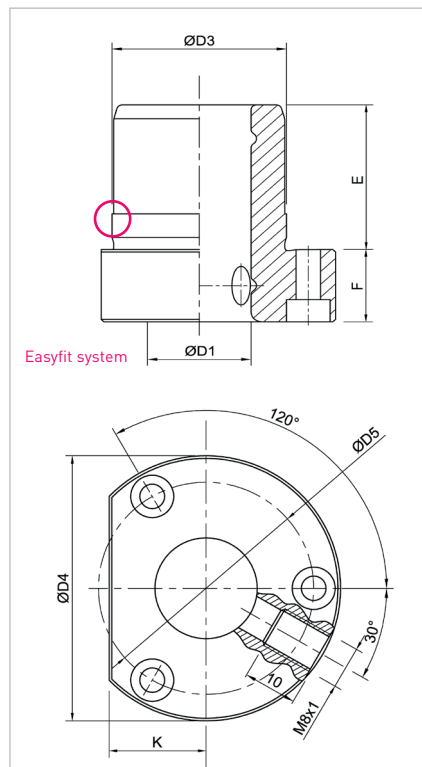
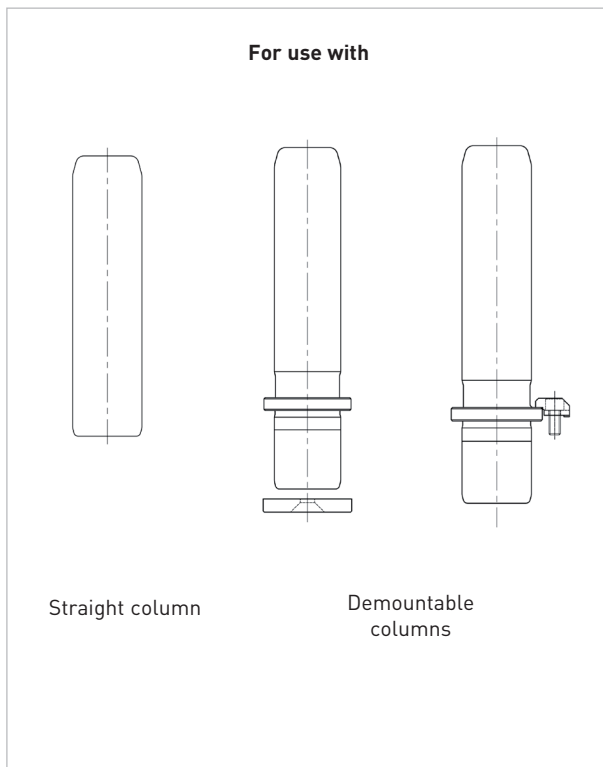

Tempered case-hardened steel bushings with a hardness of 60-64HRC, bronze- plated, with Easyfit system
Come with screws

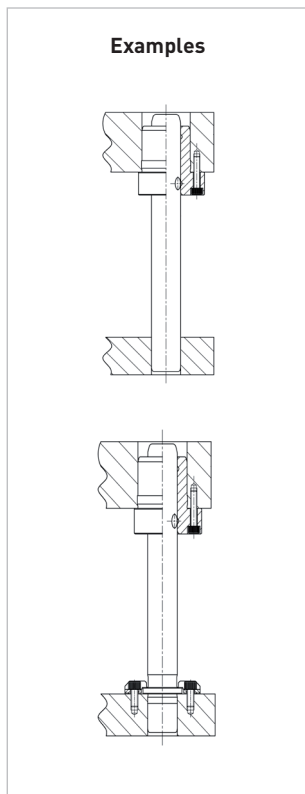

D1	19	20	24	25	30	32	40	50	63
D3	32		40		48		58	70	85
D4	50		63		72		85	104	120
D5	40		50		58		70	86	100
K	18		23		28		33	38	44

LONG SHOULDER									
D1	19	20	24	25	30	32	40	50	
E	23		23		30		30	37	
F	15		15		15		25	25	
Vis	A05.004.020		A05.005.020		A05.005.020		A05.005.030	A05.005.035	
Référence	DB31.019.038	DB31.020.038	DB31.024.038	DB31.025.038	DB31.030.045	DB31.032.045	DB31.040.055	DB31.050.062	

SHORT SHOULDER									
D1	19	20	24	25	30	32	40	50	63
E	30		30		37		37	47	60
F	15		25		25		30	42	42
Vis	A05.004.020		A05.005.030		A05.005.030		A05.005.035	A05.005.050	A05.008.050
Référence	DB31.019.045	DB31.020.045	DB31.024.055	DB31.025.055	DB31.030.062	DB31.032.062	DB31.040.067	DB31.050.089	DB31.063.089

NOTE

Large empty area with horizontal dotted lines for writing notes.



DIN 9831 compatible

Example

Column D1=40 - F=45
Please state:
DB41.040.045

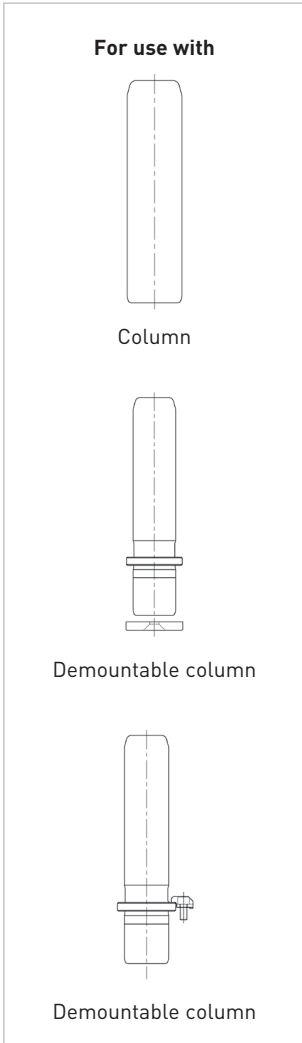

Tempered case-hardened steel bushings with a hardness of 60-64HRC, with Easyfit system
Come with fastening clamps and screws

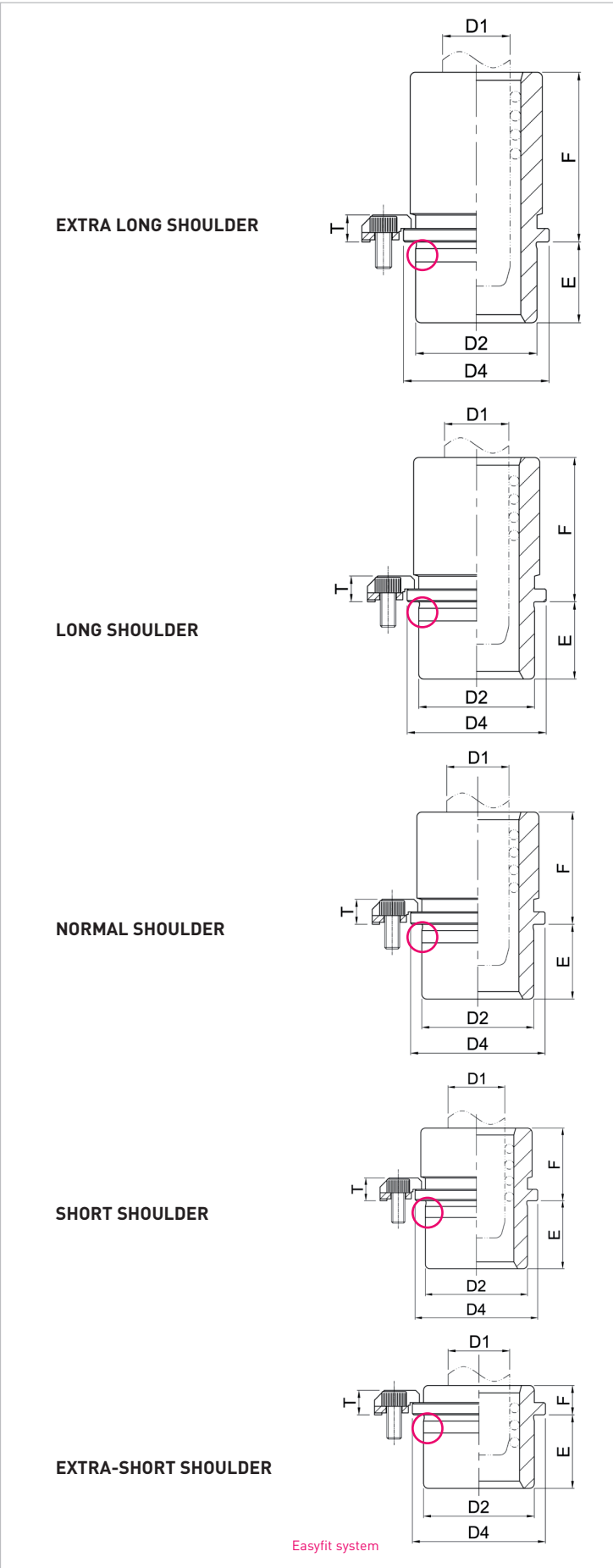
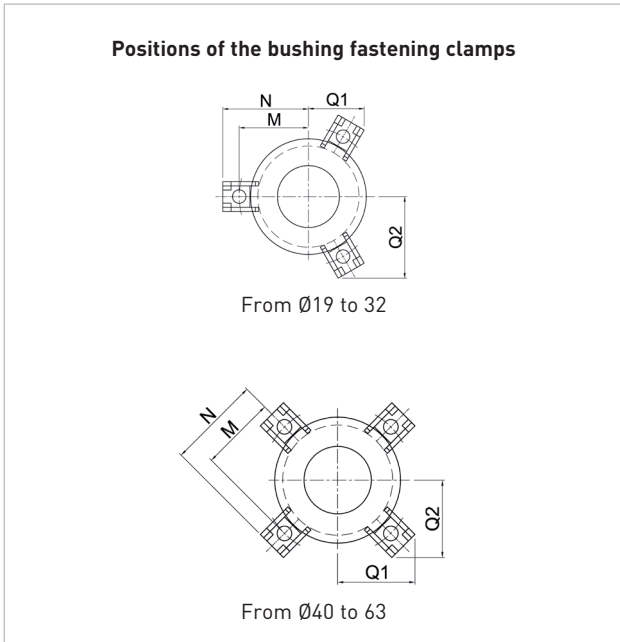

D ₁	19	20	24	25	30	32	40	50	63
D ₂	32		40		48		58	70	85
D ₃	39		46		53		63	77	92
D ₄	40		48		56		66	80	95
Qty. clamps	3		3		3		4	4	4
Ref. clamps	B02.006.100								
Vis	A05.006.012								
M	26		30		33,5		38,5	45,5	53
N	33,9		37,9		41,4		46,4	53,4	60,9
Q1	23,4		25,3		27,1		38	42,9	48,2
Q2	33,1		36,5		39,6		38	42,9	48,2
T	10								

EXTRA LONG SHOULDER									
D ₁	19	20	24	25	30	32	40	50	63
E	23		23		30		37	47	60
F	36		56		63		71	80	90
L=E+F	59		79		93		108	127	150
REFERENCE	DB41.019.036	DB41.020.036	DB41.024.056	DB41.025.056	DB41.030.063	DB41.032.063	DB41.040.071	DB41.050.080	DB41.063.090

LONG SHOULDER									
D ₁	19	20	24	25	30	32	40	50	63
E			30		37		47	60	
F			50		56		63	71	
L=E+F			80		93		110	131	
REFERENCE			DB41.024.050	DB41.025.050	DB41.030.056	DB41.032.056	DB41.040.063	DB41.050.071	

NORMAL SHOULDER									
D ₁	19	20	24	25	30	32	40	50	63
E	23		23		30		37	47	60
F	20		36		45		45	50	56
L=E+F	43		59		75		82	97	116
REFERENCE	DB41.019.020	DB41.020.020	DB41.024.036	DB41.025.036	DB41.030.045	DB41.032.045	DB41.040.045	DB41.050.050	DB41.063.056

SHORT SHOULDER									
D ₁	19	20	24	25	30	32	40	50	63
E			30		37		47	60	
F			25		32		32	36	
L=E+F			55		69		79	96	
REFERENCE			DB41.024.025	DB41.025.025	DB41.030.032	DB41.032.032	DB41.040.032	DB41.050.036	

EXTRA-SHORT SHOULDER									
D ₁	19	20	24	25	30	32	40	50	63
E	23		23		30		37	47	60
F	12		12		12		15	18	20
L=E+F	35		35		42		52	65	80
REFERENCE	DB41.019.012	DB41.020.012	DB41.024.012	DB41.025.012	DB41.030.012	DB41.032.012	DB41.040.015	DB41.050.018	DB41.063.020



Example
Cage D1=30 - Lc=70
Please state:
DC13.030.070

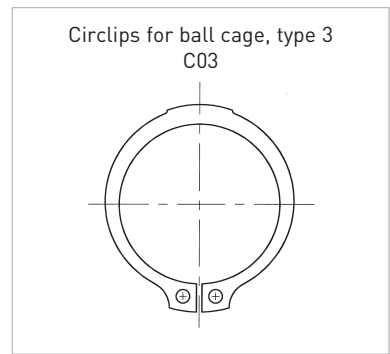
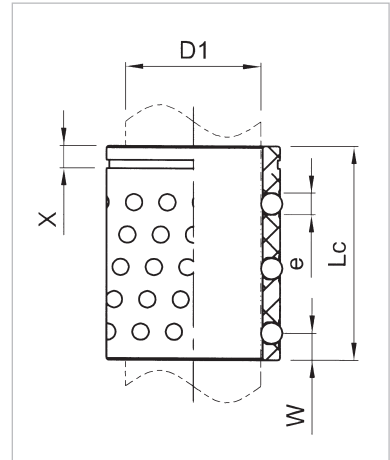
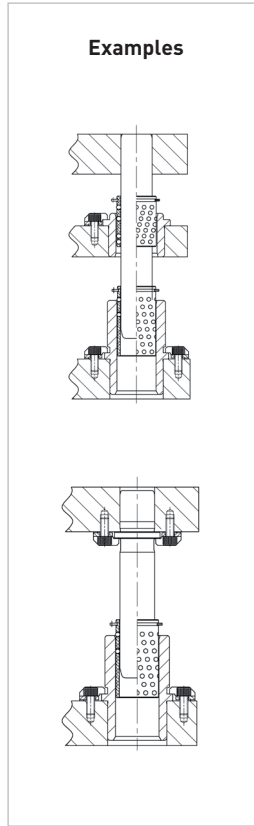
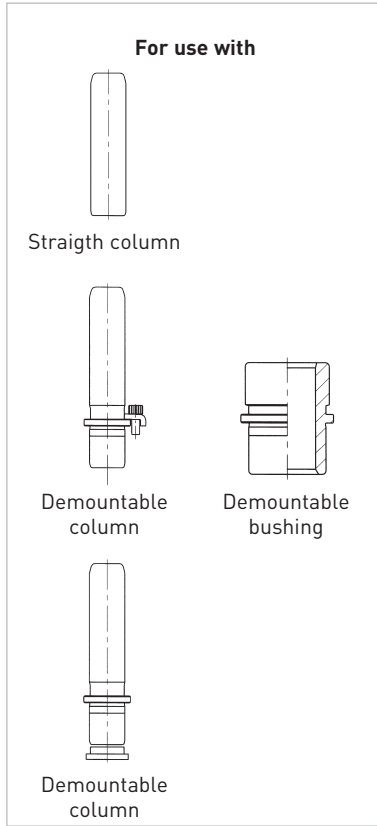

Ball cage built of monobloc aluminium alloy, processed, aircraft grade
Ball cages come with circlips

D1	19	20	24	25	30	32	40	50	63
Lc	REFERENCES								
32	DC13.019.032	DC13.020.032							
40						DC13.032.040			
44	DC13.019.044	DC13.020.044	DC13.024.044	DC13.025.044					
45						DC13.032.045			
50						DC13.032.050			
55					DC13.030.055	DC13.032.055			
56	DC13.019.056	DC13.020.056	DC13.024.056	DC13.025.056					
65							DC13.040.065		
70					DC13.030.070	DC13.032.070			
72	DC13.019.072	DC13.020.072	DC13.024.072	DC13.025.072					
80			DC13.024.080	DC13.025.080	DC13.030.080	DC13.032.080	DC13.040.080	DC13.050.080	
95					DC13.030.095	DC13.032.095	DC13.040.095	DC13.050.095	DC13.063.095
96			DC13.024.096	DC13.025.096					
105					DC13.030.105	DC13.032.105	DC13.040.105	DC13.050.105	DC13.063.105
120					DC13.030.120	DC13.032.120	DC13.040.120	DC13.050.120	DC13.063.120
140							DC13.040.140	DC13.050.140	DC13.063.140
160								DC13.050.160	DC13.063.160
180									DC13.063.180
X	2,9			3,2		4	4	4,3	4,8
e	3			3		4	4	4	4

NOTE

Large area with horizontal dotted lines for writing notes.

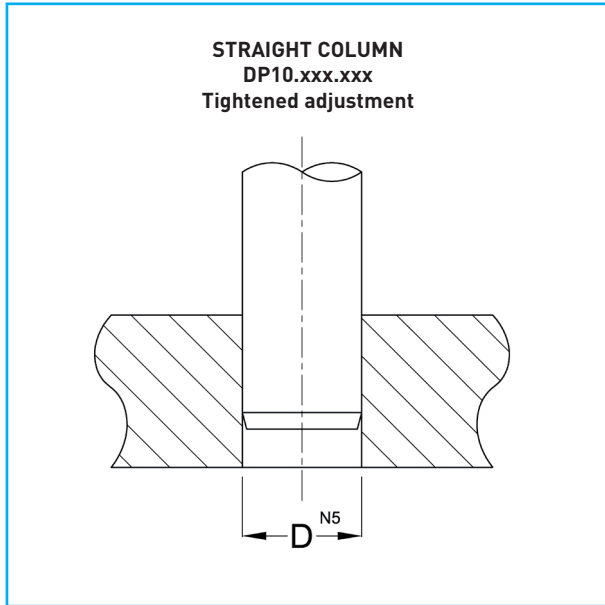

Column diameter D_1	Bore diameter D_{N5}	
19/20	19/20	-0,012 -0,021
24/25	24/25	-0,012 -0,021
30/32	30/32	-0,013 -0,024
40	40	-0,013 -0,024
50	50	-0,013 -0,024
63	63	-0,015 -0,028
80	80	-0,015 -0,028

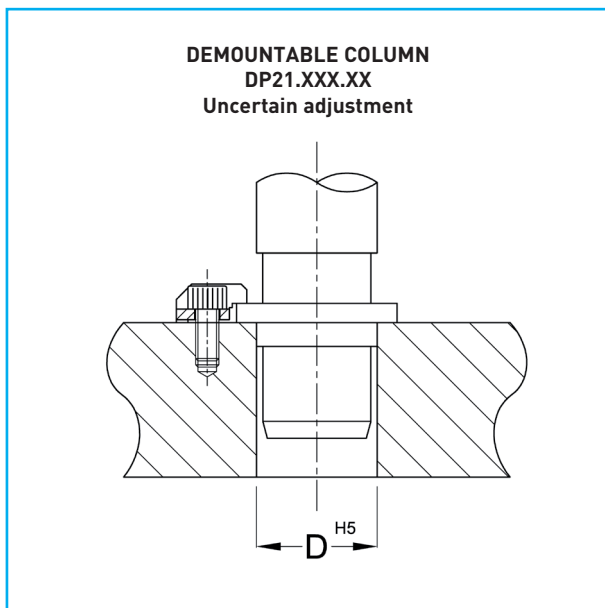

Column diameter D_1	Bore diameter D_{H5}		Adjustment Mini Maxi
19/20	+0,003 -0,003	19/20	+0,009 0 +0,012 -0,003
24/25	+0,003 -0,003	24/25	+0,009 0 +0,012 -0,003
30/32	+0,003 -0,003	30/32	+0,011 0 +0,014 -0,003
40	+0,003 -0,003	40	+0,011 0 +0,014 -0,003
50	+0,003 -0,003	50	+0,011 0 +0,014 -0,003
63	+0,003 -0,003	63	+0,013 0 +0,016 -0,003
80	+0,003 -0,003	80	+0,013 0 +0,016 -0,003

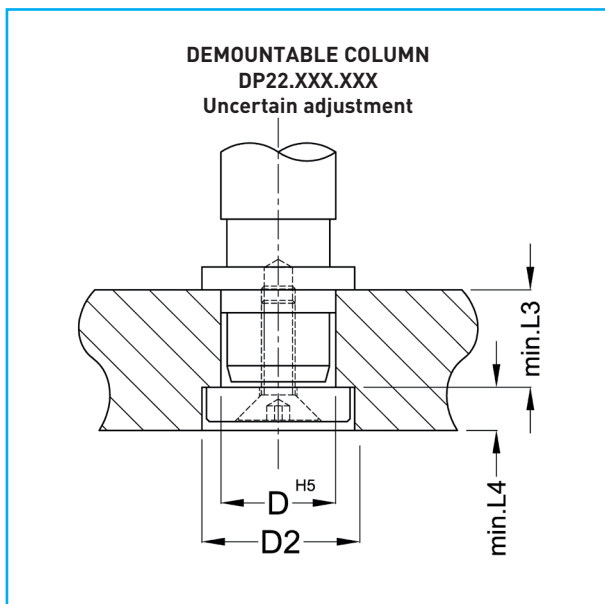

Column diameter D_1	Bore diameter D_{H5}		D_2	L_3	L_4	
19/20	+0,003 -0,003	19/20	+0,009 0	27	23,5	6,5
24/25	+0,003 -0,003	24/25	+0,009 0	34	30,5	6,5
30/32	+0,003 -0,003	30/32	+0,011 0	42	37,5	6,5
40	+0,003 -0,003	40	+0,011 0	52	37,5	6,5
50	+0,003 -0,003	50	+0,011 0	62	47,5	6,5
63	+0,003 -0,003	63	+0,013 0	72	47,5	6,5
80	+0,003 -0,003	80	+0,013 0	95	60,5	12,5

DEMOUNTABLE STEEL/BRONZE-PLATED BUSHINGS
DB11.xxx.xxx

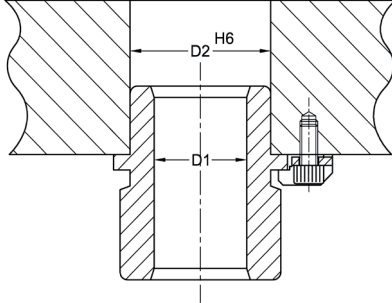

Nominal diameter D1	Bushing diameter D2	Bore diameter D2 H6	Adjustment Mini Maxi
19/20	32 +0,003 -0,003	32 +0,016 +0,000	+0,019 -0,003
24/25	40 +0,003 -0,003	40 +0,016 +0,000	+0,019 -0,003
30/32	48 +0,003 -0,003	48 +0,016 +0,000	+0,019 -0,003
40	58 +0,003 -0,003	58 +0,019 +0,000	+0,022 -0,003
50	70 +0,003 -0,003	70 +0,019 +0,000	+0,022 -0,003
63	85 +0,003 -0,003	85 +0,022 +0,000	+0,025 -0,003
80	105 +0,003 -0,003	105 +0,022 +0,000	+0,025 -0,003

DEMOUNTABLE FLANGED BUSHINGS
DB31.xxx.xxx

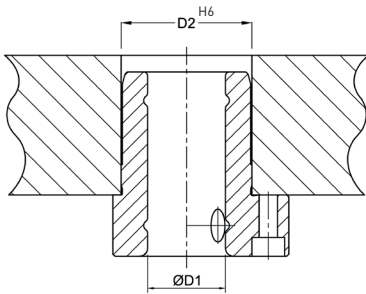

Nominal diameter D1	Bushing diameter D2	Bore diameter D2 H6	Adjustment Mini Maxi
19/20	32 +0,003 -0,003	32 +0,016 +0,000	+0,019 -0,003
24/25	40 +0,003 -0,003	40 +0,016 +0,000	+0,019 -0,003
30/32	48 +0,003 -0,003	48 +0,016 +0,000	+0,014 -0,003
40	58 +0,003 -0,003	58 +0,019 +0,000	+0,014 -0,003
50	70 +0,003 -0,003	70 +0,019 +0,000	+0,016 -0,003
63	85 +0,003 -0,003	85 +0,022 +0,000	+0,016 -0,003

STEEL BALL BEARINGS GUIDE BUSHING
DB41.XXX.XXX

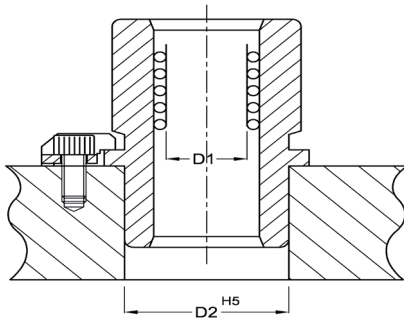

Nominal diameter D1	Bushing diameter D2	Bore diameter D2 H5	Adjustment Mini Maxi
19/20	32 +0,003 -0,003	32 +0,011 +0,000	+0,014 -0,003
24/25	40 +0,003 -0,003	40 +0,011 +0,000	+0,014 -0,003
30/32	48 +0,003 -0,003	48 +0,011 +0,000	+0,014 -0,003
40	58 +0,003 -0,003	58 +0,013 +0,000	+0,016 -0,003
50	70 +0,003 -0,003	70 +0,013 +0,000	+0,016 -0,003
63	85 +0,003 -0,003	85 +0,015 +0,000	+0,018 -0,003

CLAMPS (SCREWLESS)

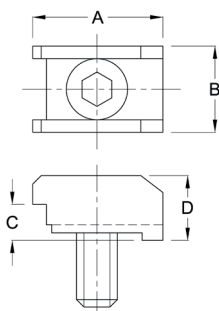

FASTENING CLAMPS

A	18,3
B	14,5
C	6
D	10
Qty of clamps	From Ø 19 to 32: 3 clamps From Ø 40 to 80: 4 clamps
Reference	B02.006.100
Screw reference code	A05.006.012

FASTENING WASHER

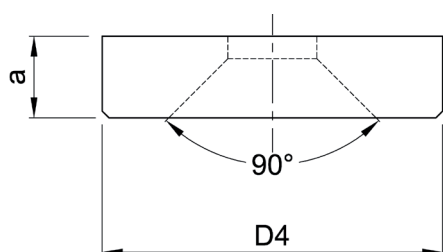

FASTENING WASHER FOR DP22 COLUMN

Reference	Ø Column	D4	a
P02.020.100	19 / 20	25	6
P02.025.100	24 / 25	32	6
P02.032.100	30 / 32	40	6
P02.040.100	40	50	6
P02.050.100	50	60	6
P02.063.100	63	70	6
P02.080.100	80	93	12

BALL CAGE CIRCLIPS

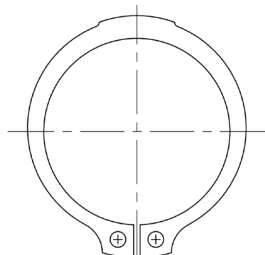

CIRCLIPS FOR DC13 BALL CAGE

Reference	Ø Ball cage
C03.019.100	19
C03.020.100	20
C03.024.100	24
C03.025.100	25
C03.030.038	30
C03.032.040	32
C03.040.048	40
C03.050.100	50
C03.063.100	63

GREASING KIT

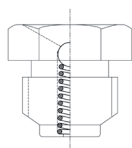

GREASING KIT FOR SMOOTH GUIDE BUSHINGS

Reference	G03.008.100
Thread	M8
Greasing kit includes: 4 greasers	

SCREW

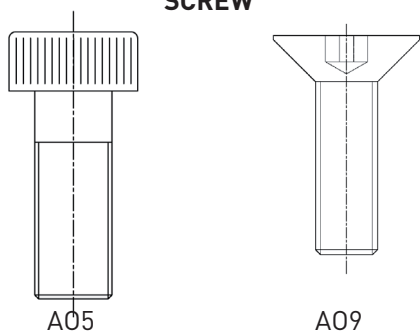

SCREW

Reference	Type
A05.004.020	Screw CHC M4 x 20
A05.005.020	Screw CHC M5 x 20
A05.005.030	Screw CHC M5 x 30
A05.006.030	Screw CHC M6 x 30
A05.006.035	Screw CHC M6 x 35
A05.008.050	Screw CHC M8 x 50
A05.006.012	Screw CHC M6 X 12
A09.008.020	Screw FHC M8 X 20
A09.012.025	Screw FHC M12 X 25



**ISO
STANDARD**

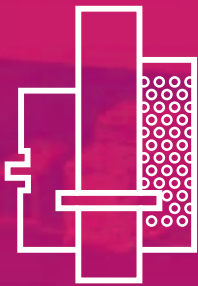













Guiding elements

MDL[®]



AMDL[®]
Atelier Mécanique De La Lauch

GUIDING ELEMENTS CONTENTS

■ Straight guide pillar lisse P10		115
■ Demountable guide pillar with fixing clamps P21		116
■ Demountable guide pillar with central fixing P22		117
■ Demountable steel guide bushes B10 - B12		118
■ Demountable bronze plated guide bush B20 - B22		120
■ Demountable bronze inserted guide bush B20I - B22I		122
■ Straight sleeve ball bearing bush B30		124
■ Demountable ball bearing bush B40		125
■ Stripper plate - demountable ball bearing bushes B42		126
■ Type 3 ball bearing cage C13		127
■ Type 1 and 2 ball bearing cage C11-C12		128 129
■ Demountable steel block for pillar of bush R05 - R06 - R07 - R08		130 131
■ Assembly instructions		134 135
■ Guide elements selection - Type 1		136 137
■ Guide elements selection - Type 2		138 - 140
■ Guide elements selection - Type 3		141
■ Accessories		142



Case-hardened and tempered to 60 - 64 HRC

Ordering example

Pillar D1=30 - L=160
P10.030.160

To be used with

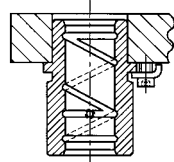

Steel bush
Bronze-plated bush

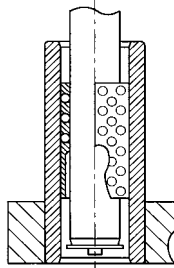

Flanged bearing bush
Ball bearing cage

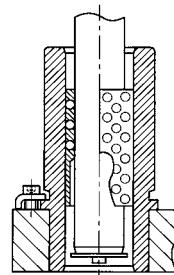

Demountable bush
Ball bearing cage

Examples

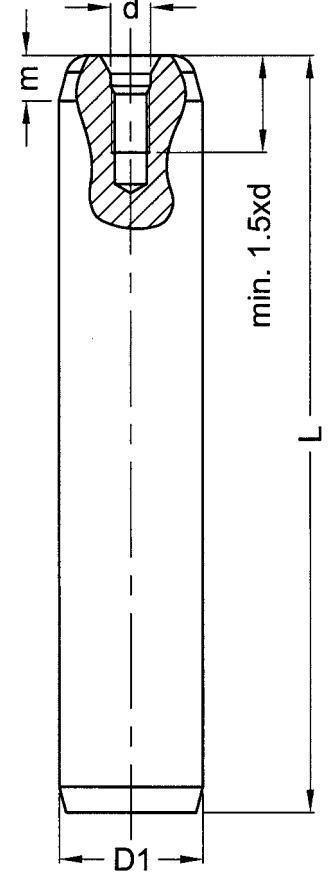
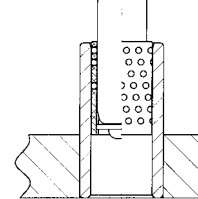
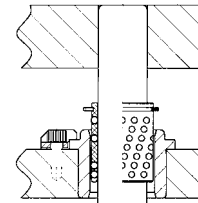
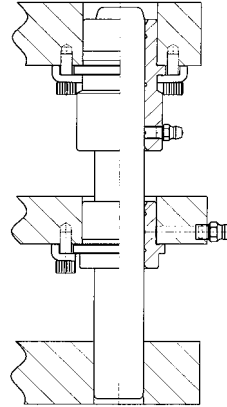

D ₁	19	20	24	25	30	32	38	40	48	50	63	80	
d	M5		M6			M8		M10		M12		M16	M20
m	6		8			8		8		8		8	8
L	REFERENCES												
100	P10.019.100	P10.020.100	P10.024.100	P10.025.100									
110	P10.019.110	P10.020.110	P10.024.110	P10.025.110	P10.030.110	P10.032.110							
125	P10.019.125	P10.020.125	P10.024.125	P10.025.125	P10.030.125	P10.032.125	P10.038.125	P10.040.125					
140	P10.019.140	P10.020.140	P10.024.140	P10.025.140	P10.030.140	P10.032.140	P10.038.140	P10.040.140					
160	P10.019.160	P10.020.160	P10.024.160	P10.025.160	P10.030.160	P10.032.160	P10.038.160	P10.040.160	P10.048.160	P10.050.160			
180	P10.019.180	P10.020.180	P10.024.180	P10.025.180	P10.030.180	P10.032.180	P10.038.180	P10.040.180	P10.048.180	P10.050.180			
200	P10.019.200	P10.020.200	P10.024.200	P10.025.200	P10.030.200	P10.032.200	P10.038.200	P10.040.200	P10.048.200	P10.050.200	P10.063.200		
220			P10.024.220	P10.025.220	P10.030.220	P10.032.220	P10.038.220	P10.040.220	P10.048.220	P10.050.220	P10.063.220		
250			P10.024.250	P10.025.250	P10.030.250	P10.032.250	P10.038.250	P10.040.250	P10.048.250	P10.050.250	P10.063.250		
280			P10.024.280	P10.025.280	P10.030.280	P10.032.280	P10.038.280	P10.040.280	P10.048.280	P10.050.280	P10.063.280	P10.080.280	
315					P10.030.315	P10.032.315	P10.038.315	P10.040.315	P10.048.315	P10.050.315	P10.063.315	P10.080.315	
355							P10.038.355	P10.040.355	P10.048.355	P10.050.355	P10.063.355	P10.080.355	
400									P10.048.400	P10.050.400	P10.063.400	P10.080.400	
450									P10.048.450	P10.050.450	P10.063.450	P10.080.450	
500												P10.080.500	

DEMOUNTABLE GUIDE PILLAR

with mounting clamps

P21

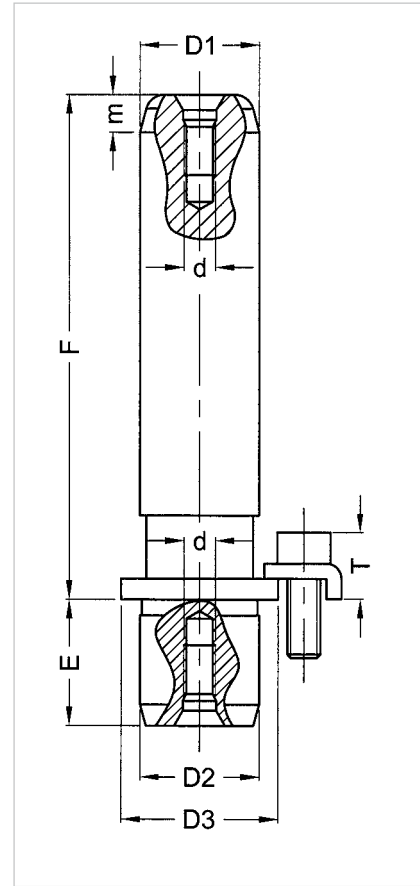
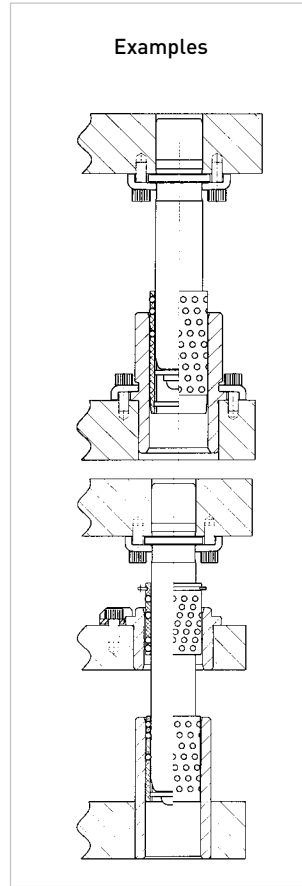
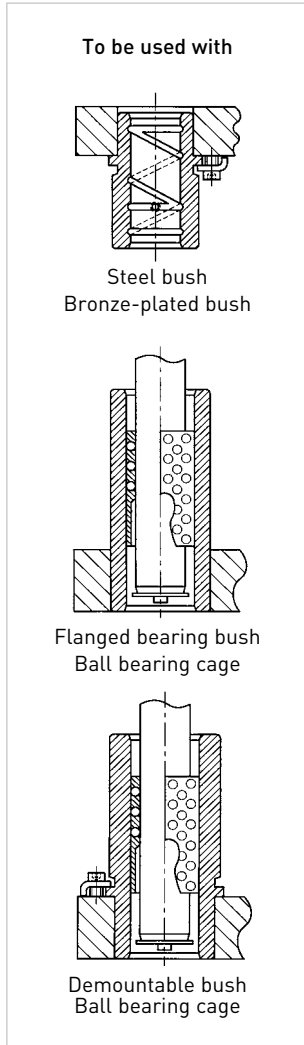

Ordering example

Pillar D1=30 - F=160
P21.030.160

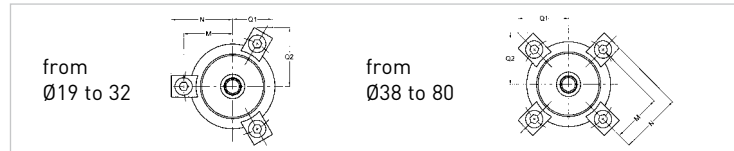

D1=D2	19	20	24	25	30	32	38	40	48	50	63	80
D3	25		32		40		50		63		76	93
E	20		25		32		40		45		50	60
d	M5		M6		M8		M10		M12		M16	M20
m	6		8		8		8		8		8	8
Qty	3		3		3		4		4		4	4
Clamp	B01.005.000		B01.006.000		B01.006.000		B01.008.000		B01.008.000		B01.008.000	B01.008.000
Screw	M5 x12		M6 x16		M6 x16		M8 x20		M8 x20		M8 x20	M8 x20
M	16		20,3		24		30		36,5		42,5	51
N	22		27,5		31,5		39,3		45,8		51,8	60,3
Q1	16,5		20,6		22,6		33,4		38		42,2	48,3
Q2	22,2		27,8		31,3		33,4		38		42,2	48,3
T	10,5		14,7		14,7		17,5		17,5		17,5	17,5
F	REFERENCES											
80	P21.019.080	P21.020.080	P21.024.080	P21.025.080								
90	P21.019.090	P21.020.090	P21.024.090	P21.025.090								
100	P21.019.100	P21.020.100	P21.024.100	P21.025.100	P21.030.100	P21.032.100	P21.038.100	P21.040.100				
110	P21.019.110	P21.020.110	P21.024.110	P21.025.110	P21.030.110	P21.032.110	P21.038.110	P21.040.110	P21.048.110	P21.050.110		
125	P21.019.125	P21.020.125	P21.024.125	P21.025.125	P21.030.125	P21.032.125	P21.038.125	P21.040.125	P21.048.125	P21.050.125	P21.063.125	
140	P21.019.140	P21.020.140	P21.024.140	P21.025.140	P21.030.140	P21.032.140	P21.038.140	P21.040.140	P21.048.140	P21.050.140	P21.063.140	
160	P21.019.160	P21.020.160	P21.024.160	P21.025.160	P21.030.160	P21.032.160	P21.038.160	P21.040.160	P21.048.160	P21.050.160	P21.063.160	
180			P21.024.180	P21.025.180	P21.030.180	P21.032.180	P21.038.180	P21.040.180	P21.048.180	P21.050.180	P21.063.180	
200			P21.024.200	P21.025.200	P21.030.200	P21.032.200	P21.038.200	P21.040.200	P21.048.200	P21.050.200	P21.063.200	P21.080.200
220					P21.030.220	P21.032.220	P21.038.220	P21.040.220	P21.048.220	P21.050.220	P21.063.220	P21.080.220
250					P21.030.250	P21.032.250	P21.038.250	P21.040.250	P21.048.250	P21.050.250	P21.063.250	P21.080.250
280					P21.030.280	P21.032.280	P21.038.280	P21.040.280	P21.048.280	P21.050.280	P21.063.280	P21.080.280
315									P21.048.315	P21.050.315	P21.063.315	P21.080.315
355									P21.048.355	P21.050.355	P21.063.355	P21.080.355
400									P21.048.400	P21.050.400	P21.063.400	P21.080.400



Ordering example

Pillar D1=30 - F=160
P22.030.160

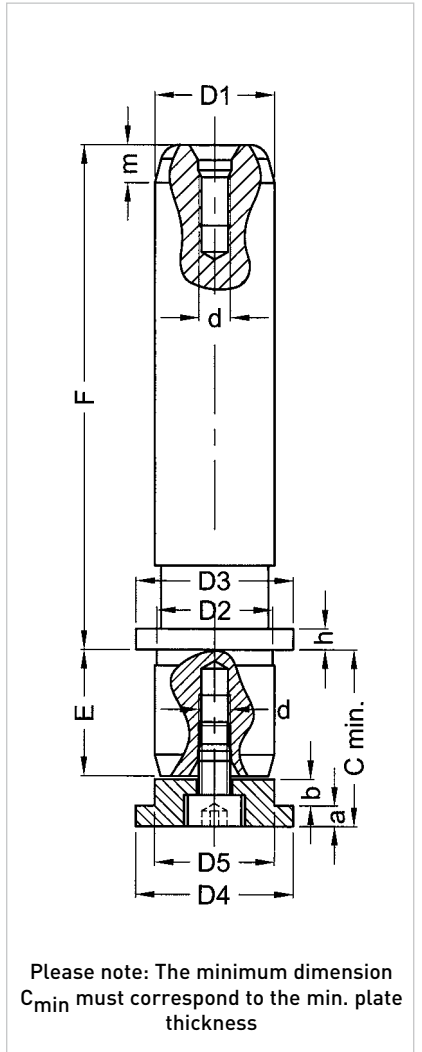
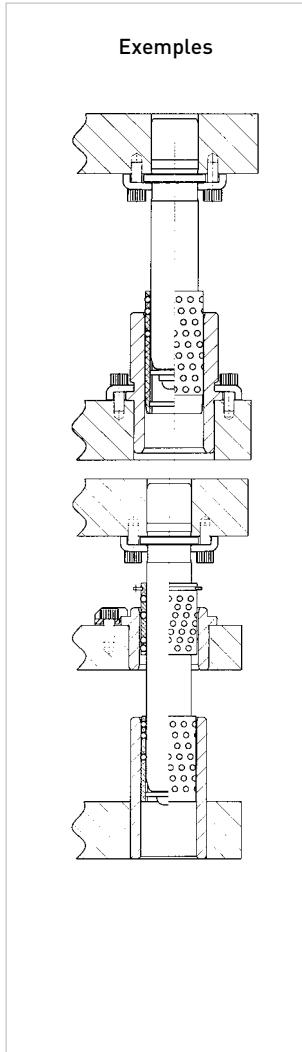
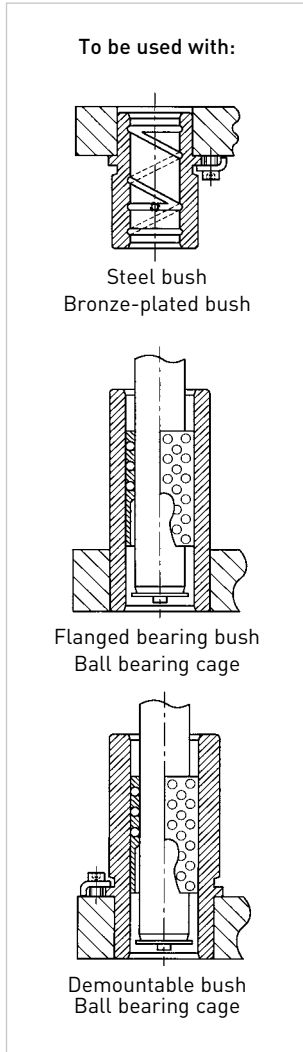

D1=D2	19	20	24	25	30	32	38	40	48	50	63	80
D3	25		32		40		50		63		76	93
D4	25		32		40		50		63		76	93
D5	19		24		30		38		48		63	80
E	20		25		32		40		45		50	60
d	M5		M6		M8		M10		M12		M16	M20
m	6		8		8		8		8		8	8
a	3,3		5		5		5		5		5	5
b	4,2		4		7		10		13		19	25
C min	28		35		45		56		64		75	91
Washer	P02.020.000		P02.025.000		P02.032.000		P02.040.000		P02.050.000		P02.063.000	P02.080.000
h	3,3		5		5		5		5		5	5
F	REFERENCES											
80	P22.019.080	P22.020.080	P22.024.080	P22.025.080								
90	P22.019.090	P22.020.090	P22.024.090	P22.025.090								
100	P22.019.100	P22.020.100	P22.024.100	P22.025.100	P22.030.100	P22.032.100	P22.038.100	P22.040.100				
110	P22.019.110	P22.020.110	P22.024.110	P22.025.110	P22.030.110	P22.032.110	P22.038.110	P22.040.110	P22.048.110	P22.050.110		
125	P22.019.125	P22.020.125	P22.024.125	P22.025.125	P22.030.125	P22.032.125	P22.038.125	P22.040.125	P22.048.125	P22.050.125	P22.063.125	
140	P22.019.140	P22.020.140	P22.024.140	P22.025.140	P22.030.140	P22.032.140	P22.038.140	P22.040.140	P22.048.140	P22.050.140	P22.063.140	
160	P22.019.160	P22.020.160	P22.024.160	P22.025.160	P22.030.160	P22.032.160	P22.038.160	P22.040.160	P22.048.160	P22.050.160	P22.063.160	
180			P22.024.180	P22.025.180	P22.030.180	P22.032.180	P22.038.180	P22.040.180	P22.048.180	P22.050.180	P22.063.180	
200			P22.024.200	P22.025.200	P22.030.200	P22.032.200	P22.038.200	P22.040.200	P22.048.200	P22.050.200	P22.063.200	P22.080.200
220					P22.030.220	P22.032.220	P22.038.220	P22.040.220	P22.048.220	P22.050.220	P22.063.220	P22.080.220
250					P22.030.250	P22.032.250	P22.038.250	P22.040.250	P22.048.250	P22.050.250	P22.063.250	P22.080.250
280					P22.030.280	P22.032.280	P22.038.280	P22.040.280	P22.048.280	P22.050.280	P22.063.280	P22.080.280
315									P22.048.315	P22.050.315	P22.063.315	P22.080.315
355									P22.048.355	P22.050.355	P22.063.355	P22.080.355
400									P22.048.400	P22.050.400	P22.063.400	P22.080.400



Case-hardened and tempered to 60-64 HRC
Supplied with mounting clamps and screws

Ordering example

Pillar D1=40 - F=100
B10.040.100

To be used with



Pillar

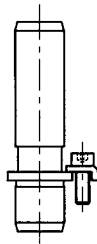

Demountable pillar

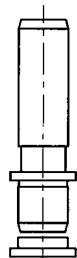

Demountable pillar

Examples

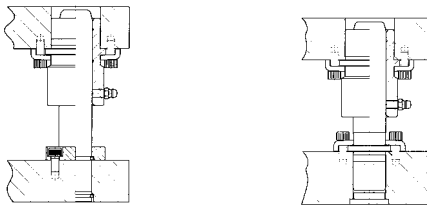

Positions of bush mounting clamps

for Ø19 to 20

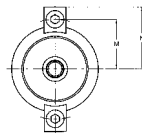

for Ø24 to 32

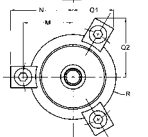

for Ø38 to 80

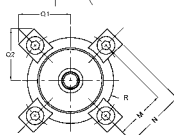

EXTRA-LONG SHOULDER Steel : B10.0xx.100

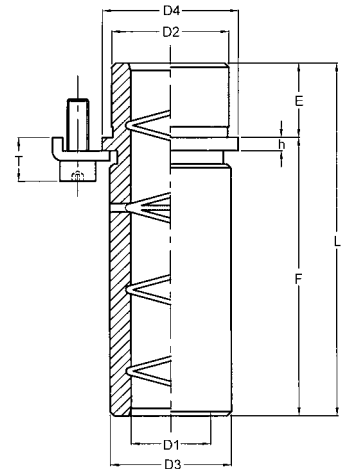

LONG SHOULDER Steel : B10.0xx.075

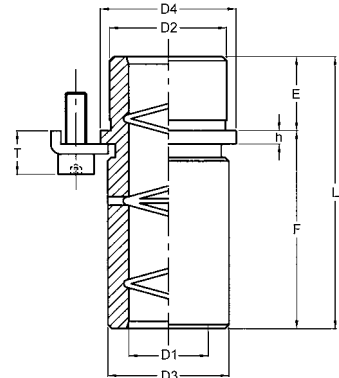

ÉPAULEMENT NORMAL Steel : B10.0xx.032 B10.0xx.050

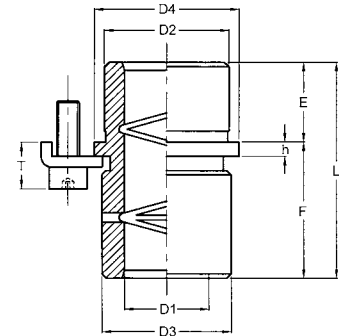

NORMAL SHOULDER Steel : B10.0xx.016 B10.0xx.020

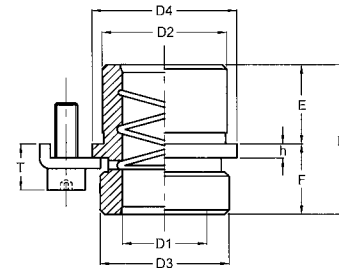

SHORT SHOULDER Steel : B12.0xx.010 B12.0xx.014

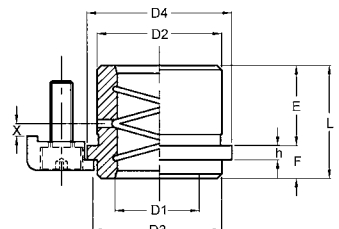

D ₁	19	20	24	25	30	32	38	40	48	50	63	80
D ₂	28		38		45		54		65		81	100
D ₃	29		42		49		58		70		88	110
D ₄	32,5		47		54		63		75		93	115
E	18		22		25		30		35		48	48
h	3,3		5		5		5		5		5	5
No. of clamps	2		3		3		4		4		4	4
Clamp ref.	B01.005.000		B01.006.000		B01.006.000		B01.008.000		B01.008.000		B01.008.000	B01.008.000
Screw	M5x12		M6x16		M6x16		M8x20		M8x20		M8x20	M8x20
M	19,5		27,5		31		37		43		52	63
N	25,5		35		38,2		46,3		52,3		61,3	72,3
Q1/R	-		24,4/23,5		26/27		30/31,5		33/37,5		37,5/46,5	43/57,5
Q2	-		34,3		37,1		44,1		49,3		57,1	66,6
T	10,5		14,7		14,7		17,5		17,5		17,5	17,5

EXTRA-LONG SHOULDER

D ₁					30	32	38	40	48	50	63	
F					100		100		100		100	
L					125		130		135		148	
Steel ref.					B10.0xx.100		B10.0xx.100		B10.0xx.100		B10.063.100	

ÉPAULEMENT LONG

D ₁			24	25	30	32	38	40	48	50	63	
F			75		75		75		75		75	
L			97		100		105		110		123	
Steel ref.			B10.0xx.075		B10.0xx.075		B10.0xx.075		B10.0xx.075		B10.063.075	

NORMAL SHOULDER

D ₁	19	20	24	25	30	32	38	40	48	50	63	80
F	32		50		50		50		50		50	50
L	50		72		75		80		85		98	98
Steel ref.	B10.0xx.032		B10.0xx.050		B10.0xx.050		B10.0xx.050		B10.0xx.050		B10.063.050	B10.080.050

SHORT SHOULDER

D ₁	19	20	24	25	30	32	38	40	48	50	63	80
F	16		20		20		20		20		20	20
L	34		42		45		50		55		68	68
Steel ref.	B10.0xx.016		B10.0xx.020		B10.0xx.020		B10.0xx.020		B10.0xx.020		B10.063.020	B10.080.020

EXTRA-SHORT SHOULDER

D ₁	19	20	24	25	30	32	38	40	48	50	63	80
D ₃	29		36		43		50		64		79	99
F	10		10		10		14		14		14	14
E	18		23		30		38		48		61	78
L	28		33		40		52		62		75	92
X	6		6		10		10		20		20	32
Clamp ref.	B01.005.000		B02.006.000		B02.006.000		B02.008.000		B02.008.000		B02.008.000	B02.008.000
Screw	M5x12		M6x12		M6x12		M8x16		M8x16		M8x16	M8x16
M	19,5		30		33,5		40		46		55	66
N	25,5		38		41,5		51,2		57,2		66,7	77,2
Q1/R	-		25,2/23,5		26,9/27		33,7/31,5		36,7/37,5		41,5/46,5	46,7/57,5
Q2	-		36,5		39,5		49,0		54,2		62,5	71,6
Steel ref.	B12.0xx.010		B12.0xx.010		B12.0xx.010		B12.0xx.014		B12.0xx.014		B12.063.014	B12.080.014



Case-hardened and tempered to 60-64 HRC

Supplied with mounting clamps and screws

Ordering example

Pillar D1=40 - L=100
B20.040.100

To be used with



Pillar

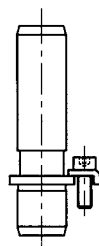

Demountable pillar

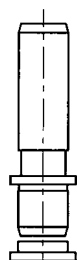

Demountable pillar

Examples

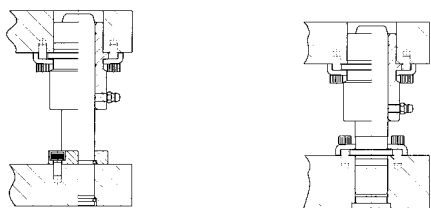

Positions of bush mounting clamps

for $\varnothing 19$ to 20

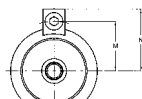

for $\varnothing 24$ to 32

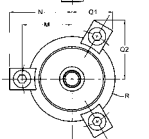

for $\varnothing 38$ to 80

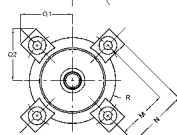

EXTRA-LONG SHOULDER
Bronze-plated :
B20.0xx.100

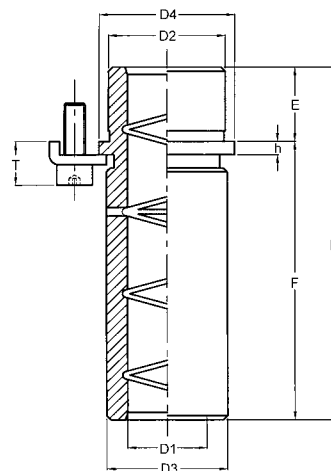

LONG SHOULDER
Bronze-plated :
B20.0xx.075

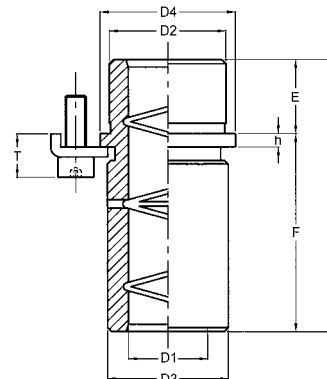

NORMAL SHOULDER
Bronze-plated :
B20.0xx.032
B20.0xx.050

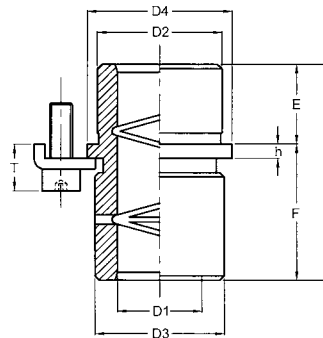

SHORT SHOULDER
Bronze-plated :
B20.0xx.016
B20.0xx.020

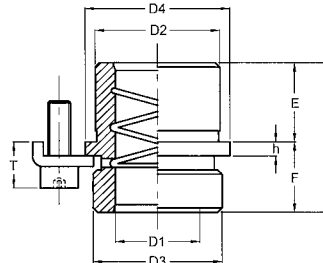

EXTRA-SHORT SHOULDER
Bronze-plated :
B22.0xx.010
B22.0xx.014

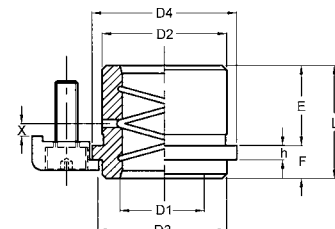

D ₁	19	20	24	25	30	32	38	40	48	50	63	80
D ₂	28		38		45		54		65		81	100
D ₃	29		42		49		58		70		88	110
D ₄	32,5		47		54		63		75		93	115
E	18		22		25		30		35		48	48
h	3,3		5		5		5		5		5	5
No. of clamps	2		3		3		4		4		4	4
Clamp ref.	B01.005.000		B01.006.000		B01.006.000		B01.008.000		B01.008.000		B01.008.000	B01.008.000
Screw	M5x12		M6x16		M6x16		M8x20		M8x20		M8x20	M8x20
M	19,5		27,5		31		37		43		52	63
N	25,5		35		38,2		46,3		52,3		61,3	72,3
Q1/R	-		24,4/23,5		26/27		30/31,5		33/37,5		37,5/46,5	43/57,5
Q2	-		34,3		37,1		44,1		49,3		57,1	66,6
T	10,5		14,7		14,7		17,5		17,5		17,5	17,5

EXTRA-LONG SHOULDER												
D ₁					30	32	38	40	48	50	63	
F					100		100		100		100	
L					125		130		135		148	
Bronze-plated ref.					B20.0xx.100		B20.0xx.100		B20.0xx.100		B20.063.100	

LONG SHOULDER												
D ₁			24	25	30	32	38	40	48	50	63	
F			75		75		75		75		75	
L			97		100		105		110		123	
Bronze-plated ref.			B20.0xx.075		B20.0xx.075		B20.0xx.075		B20.0xx.075		B20.063.075	

NORMAL SHOULDER												
D ₁	19	20	24	25	30	32	38	40	48	50	63	80
F	32		50		50		50		50		50	50
L	50		72		75		80		85		98	98
Bronze-plated ref.	B20.0xx.032		B20.0xx.050		B20.0xx.050		B20.0xx.050		B20.0xx.050		B20.063.050	B20.080.050

SHORT SHOULDER												
D ₁	19	20	24	25	30	32	38	40	48	50	63	80
F	16		20		20		20		20		20	20
L	34		42		45		50		55		68	68
Bronze-plated ref.	B20.0xx.016		B20.0xx.020		B20.0xx.020		B20.0xx.020		B20.0xx.020		B20.063.020	B20.080.020

EXTRA-SHORT SHOULDER												
D ₁	19	20	24	25	30	32	38	40	48	50	63	80
D ₃	29		36		43		50		64		79	99
F	10		10		10		14		14		14	14
E	18		23		30		38		48		61	78
L	28		33		40		52		62		75	92
X	6		6		10		10		20		20	32
Clamp ref.	B01.005.000		B02.006.000		B02.006.000		B02.008.000		B02.008.000		B02.008.000	B02.008.000
Screw	M5x12		M6x12		M6x12		M8x16		M8x16		M8x16	M8x16
M	19,5		30		33,5		40		46		55	66
N	25,5		38		41,5		51,2		57,2		66,7	77,2
Q1/R	-		25,2/23,5		26,9/27		33,7/31,5		36,7/37,5		41,5/46,5	46,7/57,5
Q2	-		36,5		39,5		49,0		54,2		62,5	71,6
Bronze-plated ref.	B22.0xx.010		B22.0xx.010		B22.0xx.010		B22.0xx.014		B22.0xx.014		B22.063.014	B22.080.014

DEMOUNTABLE BRONZE-INSERTED GUIDE BUSH

B201
B221



Ordering example

Pillar D1=40 - L=100
B201.040.100

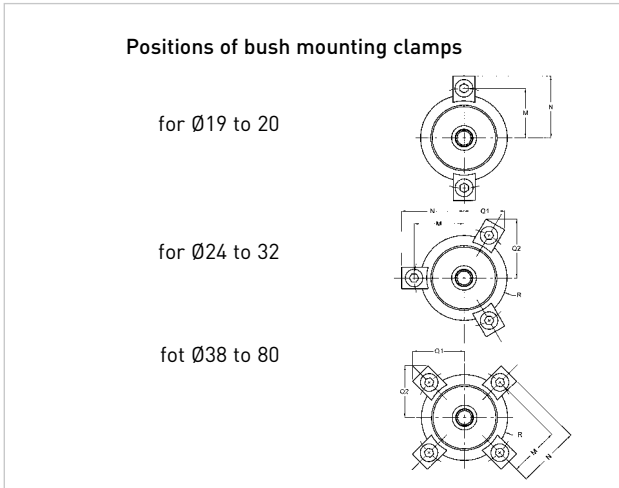
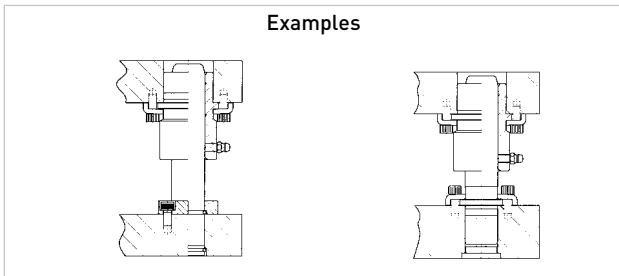
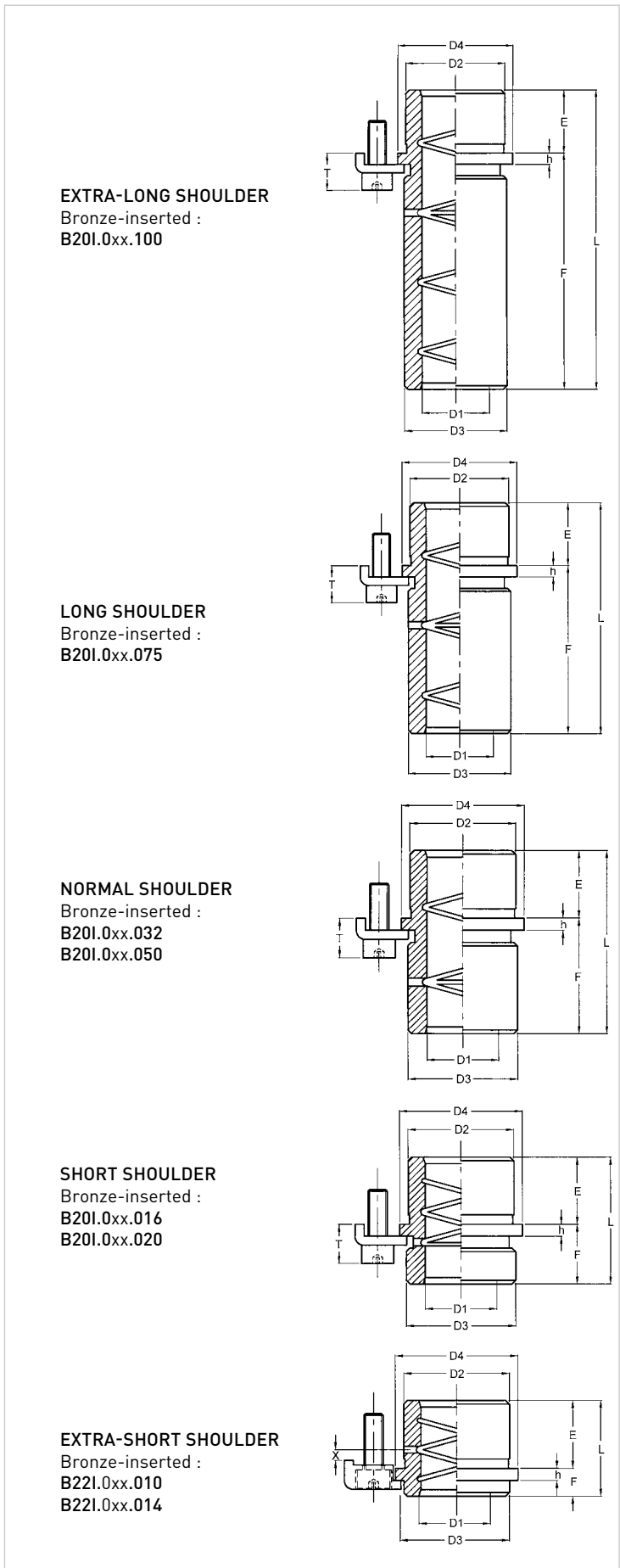
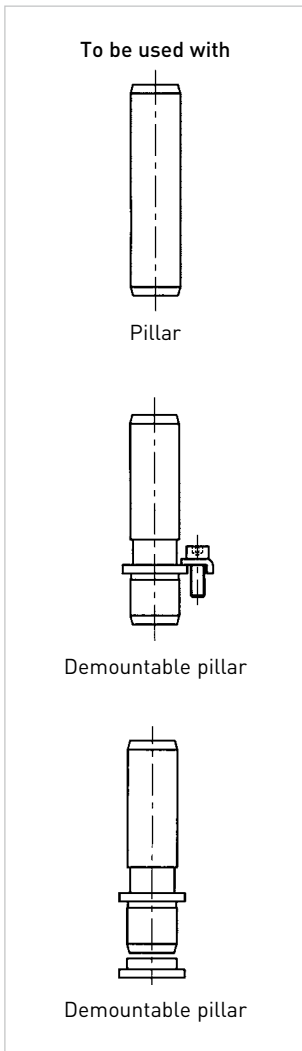

D ₁	19	20	24	25	30	32	38	40	48	50	63	80
D ₂	28		38		45		54		65		100	
D ₃	29		42		49		58		70		110	
D ₄	32,5		47		54		63		75		115	
E	18		22		25		30		35		48	
h	3,3		5		5		5		5		5	
No. of clamps	2		3		3		4		4		4	
Clamp ref.	B01.005.000		B01.006.000		B01.006.000		B01.008.000		B01.008.000		B01.008.000	
Screw	M5x12		M6x16		M6x16		M8x20		M8x20		M8x20	
M	19,5		27,5		31		37		43		63	
N	25,5		35		38,2		46,3		52,3		72,3	
Q1/R	-		24,4/23,5		26/27		30/31,5		33/37,5		37,5/46,5	
Q2	-		34,3		37,1		44,1		49,3		66,6	
T	10,5		14,7		14,7		17,5		17,5		17,5	

EXTRA-LONG SHOULDER												
D ₁					30	32	38	40	48	50	63	
F					100		100		100		100	
L					125		130		135		148	
Réf. pl. bronze					B201.0xx.100		B201.0xx.100		B201.0xx.100		B201.063.100	

LONG SHOULDER												
D ₁			24	25	30	32	38	40	48	50	63	
F			75		75		75		75		75	
L			97		100		105		110		123	
Réf. pl. bronze			B201.0xx.075		B201.0xx.075		B201.0xx.075		B201.0xx.075		B201.063.075	

ÉPAULEMENT NORMAL												
D ₁	19	20	24	25	30	32	38	40	48	50	63	80
F	32		50		50		50		50		50	
L	50		72		75		80		85		98	
Réf. pl. bronze	B201.0xx.032		B201.0xx.050		B201.0xx.050		B201.0xx.050		B201.0xx.050		B201.063.050	

SHORT SHOULDER												
D ₁	19	20	24	25	30	32	38	40	48	50	63	80
F	16		20		20		20		20		20	
L	34		42		45		50		55		68	
Réf. pl. bronze	B201.0xx.016		B201.0xx.020		B201.0xx.020		B201.0xx.020		B201.0xx.020		B201.063.020	

EXTRA-SHORT SHOULDER												
D ₁	19	20	24	25	30	32	38	40	48	50	63	80
D ₃	29		36		43		50		64		99	
F	10		10		10		14		14		14	
E	18		23		30		38		48		78	
L	28		33		40		52		62		92	
X	6		6		10		10		20		32	
Réf. brides	B01.005.000		B02.006.000		B02.006.000		B02.008.000		B02.008.000		B02.008.000	
Vis	M5x12		M6x12		M6x12		M8x16		M8x16		M8x16	
M	19,5		30		33,5		40		46		66	
N	25,5		38		41,5		51,2		57,2		77,2	
Q1/R	-		25,2/23,5		26,9/27		33,7/31,5		36,7/37,5		41,5/46,5	
Q2	-		36,5		39,5		49,0		54,2		71,6	
Réf. pl. bronze	B221.0xx.010		B221.0xx.010		B221.0xx.010		B221.0xx.014		B221.0xx.014		B221.063.014	

STRAIGHT SLEEVE BALL BEARING BUSH

B30



Made from vacuum-degassed alloy steel

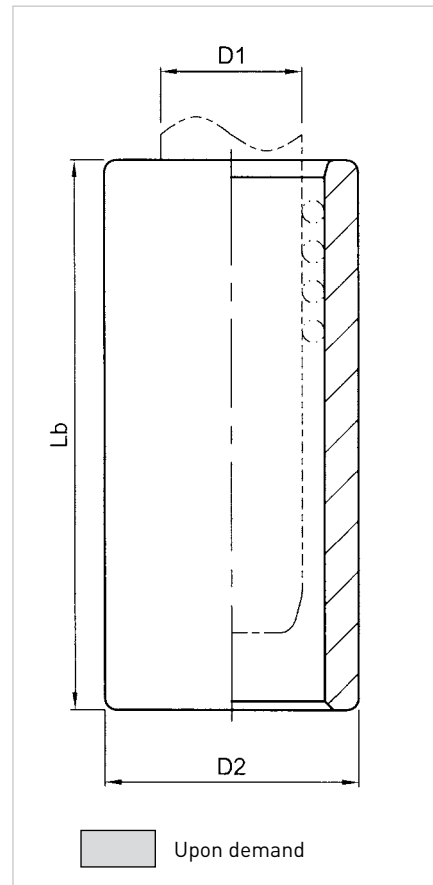
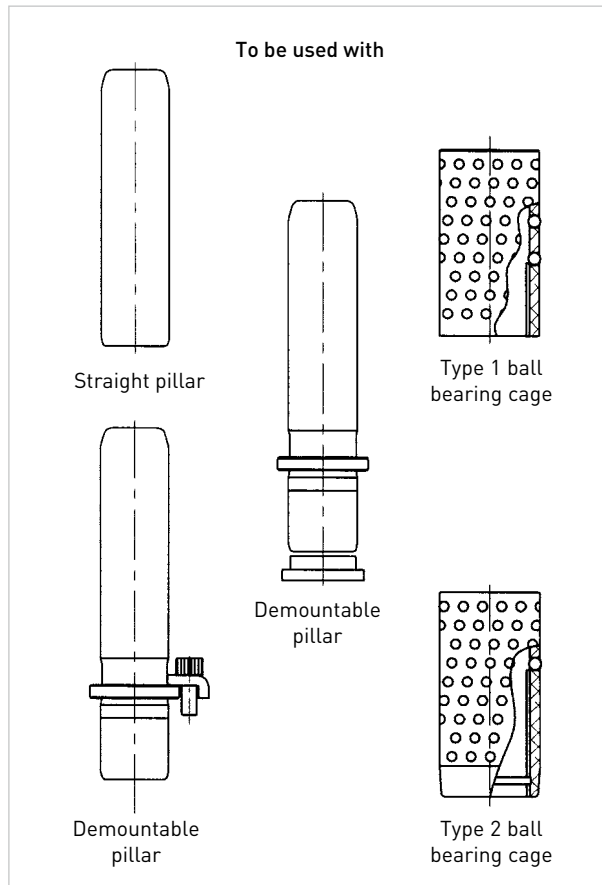

Ordering example

Pillar D1=30 - L=110
B30.030.110

D1	24	25	30	32	38	40	48	50	63	80
D2	45		54		65		81		95	112
Lb	REFERENCES									
65	B30.024.065	B30.025.065								
80	B30.024.080	B30.025.080	B30.030.080	B30.032.080	B30.038.080	B30.040.080				
95	B30.024.095	B30.025.095	B30.030.095	B30.032.095	B30.038.095	B30.040.095				
110	B30.024.110	B30.025.110	B30.030.110	B30.032.110	B30.038.110	B30.040.110	B30.048.110	B30.050.110		
130	B30.024.130	B30.025.130	B30.030.130	B30.032.130	B30.038.130	B30.040.130	B30.048.130	B30.050.130		
150			B30.030.150	B30.032.150	B30.038.150	B30.040.150	B30.048.150	B30.050.150	B30.063.150	B30.080.150
170			B30.030.170	B30.032.170	B30.038.170	B30.040.170	B30.048.170	B30.050.170	B30.063.170	B30.080.170
190					B30.038.190	B30.040.190	B30.048.190	B30.050.190	B30.063.190	B30.080.190
215					B30.038.215	B30.040.215	B30.048.215	B30.050.215	B30.063.215	B30.080.215
240							B30.048.240	B30.050.240	B30.063.240	B30.080.240
265							B30.048.265	B30.050.265	B30.063.265	B30.080.265

Examples

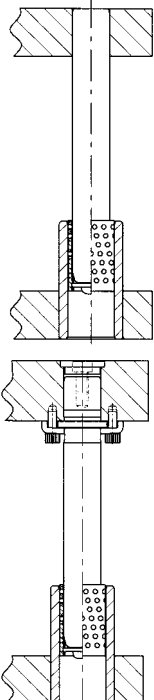

ASSEMBLY INSTRUCTIONS

Straight sleeve ball bearing bushes are glued into the plate

1. Degrease with acetone or a similar solvent and thoroughly wipe clean the outer surface of the straight sleeve bush and the inside of the plate bore.
2. Apply a thin layer of Loctite 601 glue to both surfaces.
3. Insert the bush into the hole while turning.
4. Leave to set for the required amount of time (e.g. 4 hours at 22°C)

To select, please refer to pages 26-27

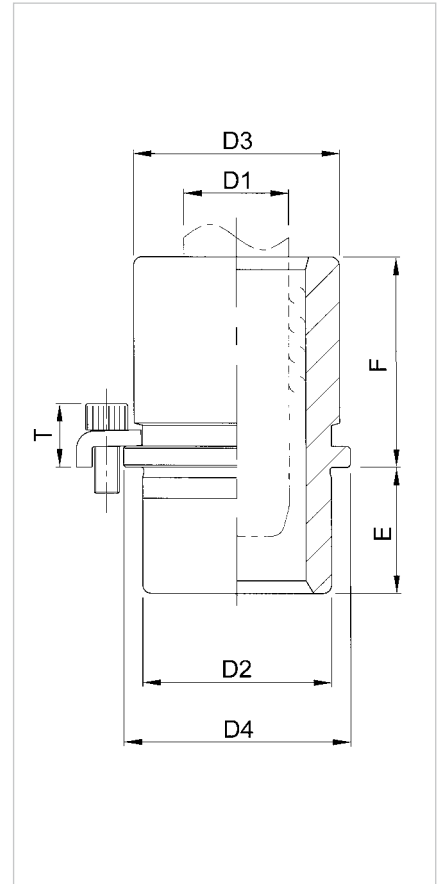
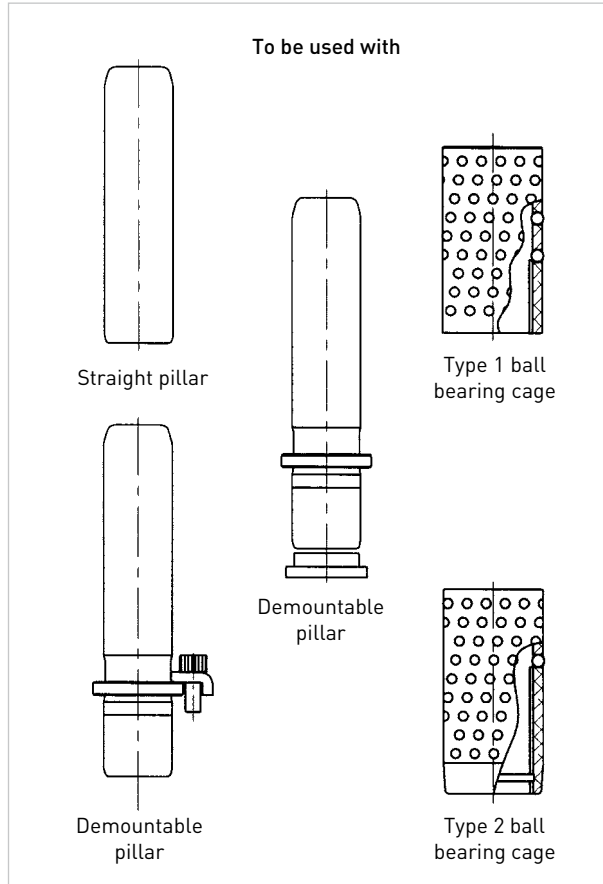

Ordering example
Pillar D1=30 - F=80
B40.030.80

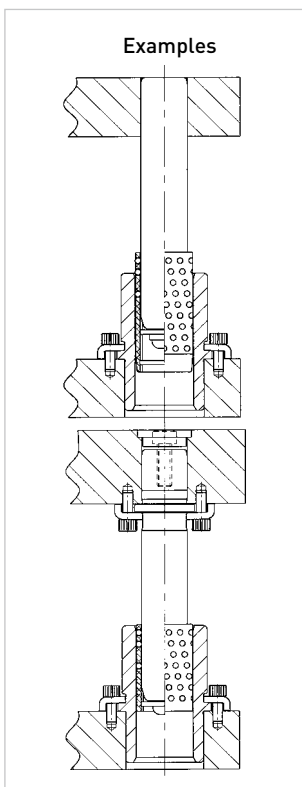
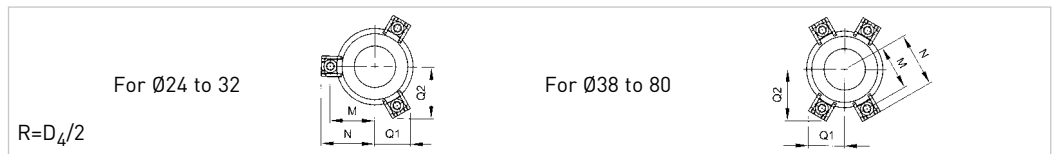

D1	24	25	30	32	38	40	48	50	63	80
F	REFERENCES									
35	B40.024.035	B40.025.035								
50	B40.024.050	B40.025.050	B40.030.050	B40.032.050	B40.038.050	B40.040.050				
65	B40.024.065	B40.025.065	B40.030.065	B40.032.065	B40.038.065	B40.040.065	B40.048.065	B40.050.065		
80			B40.030.080	B40.032.080	B40.038.080	B40.040.080	B40.048.080	B40.050.080		
100					B40.038.100	B40.040.100	B40.048.100	B40.050.100	B40.063.100	B40.080.100
120							B40.048.120	B40.050.120	B40.063.120	B40.080.120
140									B40.063.140	B40.080.140
D2	45		54		65		81		95	112
D3	49		58		70		88		103	120
D4	54		63		75		93		108	125
E			30					50		
	FIXING CLAMPS									
D1	24	25	30	32	38	40	48	50	63	80
Qt.	3		3		4		4		4	4
Ref.	B01.006.000			B01.008.000						
Screw	M6x16			M8x20						
M	31		37		43		52		60	68
N	38,2		46,3		52,3		61,3		69,3	78,7
Q1/R	26/27		30/31,5		33/37,5		37,5/46,5		41,5/54	46/62,5
Q2	37,1		44,1		49,3		57,1		64,0	71,8
T	14,7		17,5							

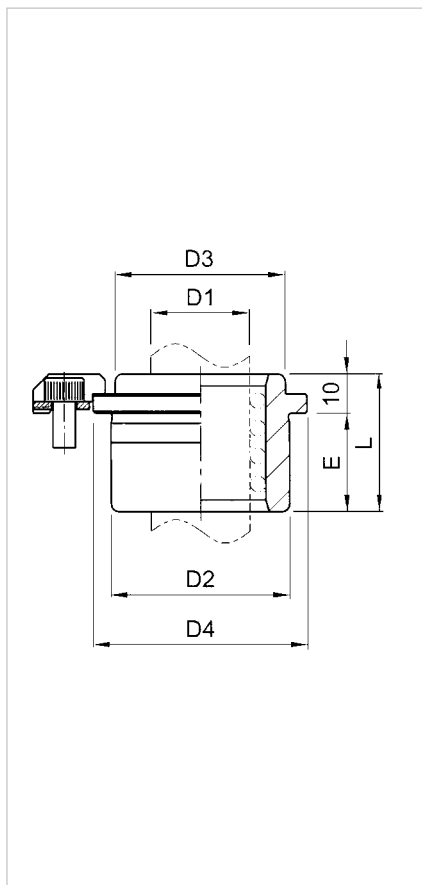
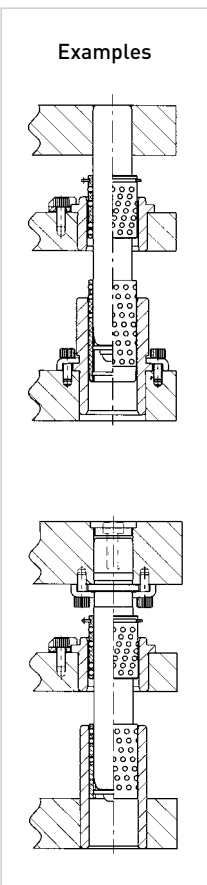
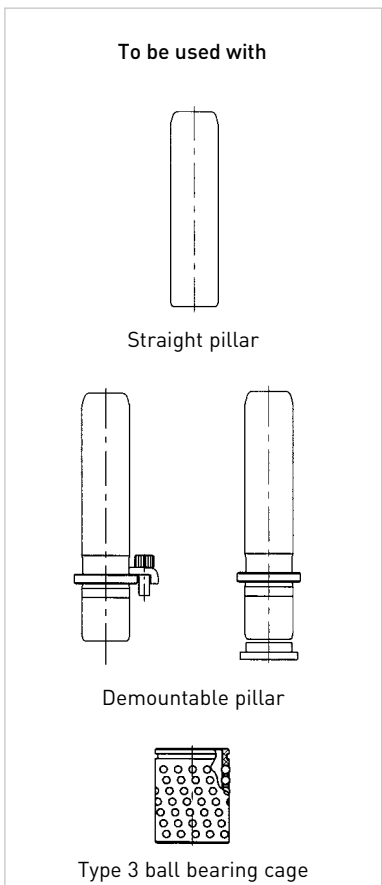

Ordering example
Pillar D1=30 - E=32
B42.030.042

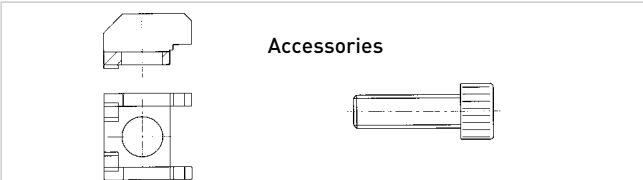
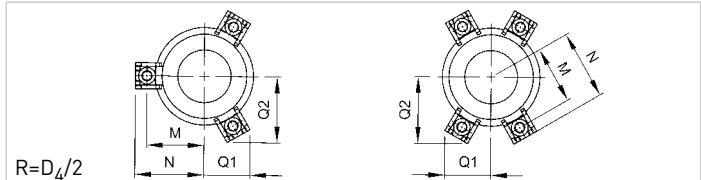

D1	24	25	30	32	38	40	48	50
E	REFERENCE							
20	B42.024.030	B42.025.030	B42.030.030	B42.032.030				
25	B42.024.035	B42.025.035	B42.030.035	B42.032.035				
29			B42.030.039	B42.032.039	B42.038.039	B42.040.039		
32			B42.030.042	B42.032.042	B42.038.042	B42.040.042		
36					B42.038.046	B42.040.046	B42.048.046	B42.050.046
44					B42.038.054	B42.040.054	B42.048.054	B42.050.054
D2	45		54		65		81	
D3	43		50		64		79	
D4	54		63		75		93	
Clamps	B02.006.000							
Qty	3		3		4		4	
Screw	M6x12		M6x12		M6x12		M6x12	
M	33,5		38		44		53	
N	41,5		46		52,4		61	
Q1/R	26,9/27		29,2/31,5		32,2/37,5		36,7/46,5	
Q2	39,5		43,4		48,6		56,4	



Ordering example
Pillar D1=30 - Lc=63
C13.030.063

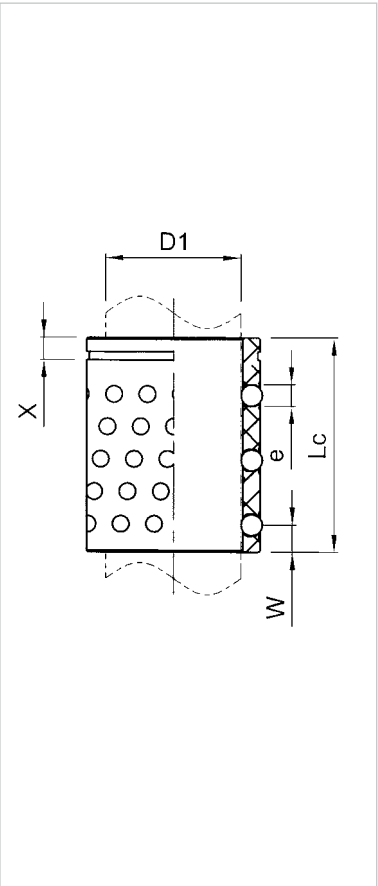
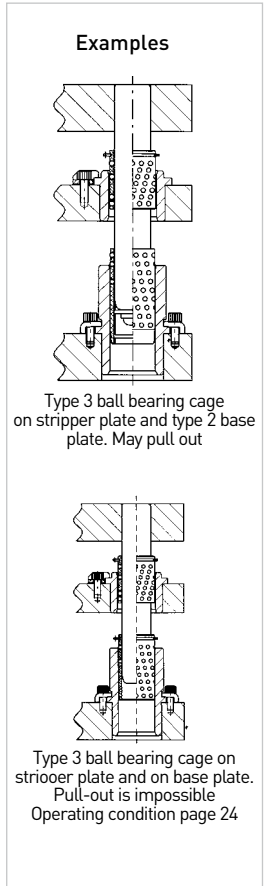
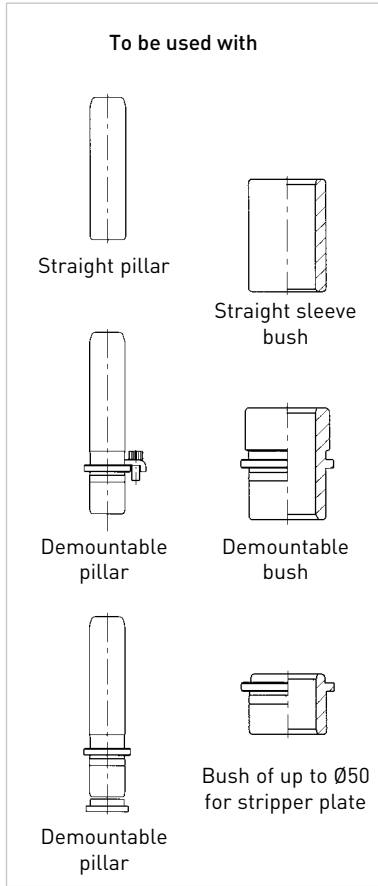

The choice of ball bearing cage for the stripper plate depends upon the guide diameter, the stroke of the stripper plate [C_i] in relation to the pillar support plate, and the depth (Lc) of the ball bearing cages required is determined by the following formula :

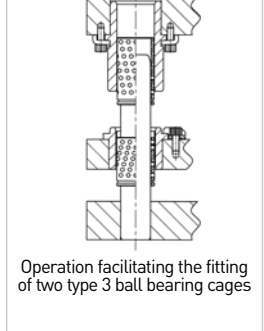
$$Lc \geq \frac{C_i + E + 10 + X}{2}$$

D1	24	25	30	32	38	40	48	50	63	80
Lc	REFERENCE									
40	C13.024.040	C13.025.040	C13.030.040	C13.032.040						
52	C13.024.052	C13.025.052	C13.030.052	C13.032.052	C13.038.052	C13.040.052				
63	C13.024.063	C13.025.063	C13.030.063	C13.032.063	C13.038.063	C13.040.063	C13.048.063	C13.050.063		
80	C13.024.080	C13.025.080	C13.030.080	C13.032.080	C13.038.080	C13.040.080	C13.048.080	C13.050.080		
100			C13.030.100	C13.032.100	C13.038.100	C13.040.100	C13.048.100	C13.050.100	C13.063.100	
125					C13.038.125	C13.040.125	C13.048.125	C13.050.125	C13.063.125	C13.080.125
140										C13.080.140
X	4,2		4,9		5,7			6,7		
e	4			6				6		
W	5,0		5,3		4,8			5,6		



Ordering example
Pillar D1=30 - Lc=105
C12.030.105

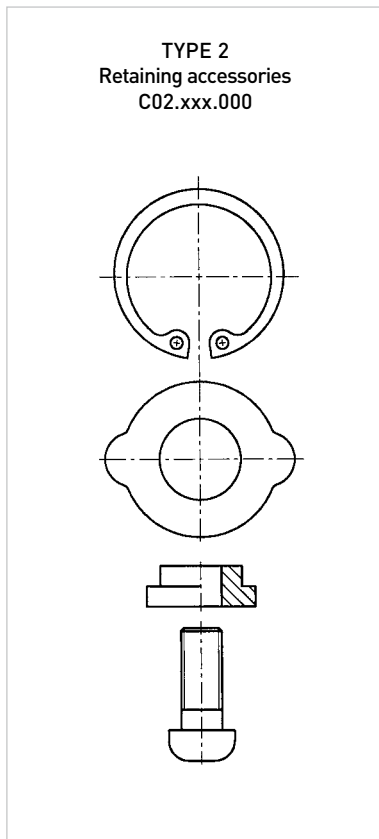
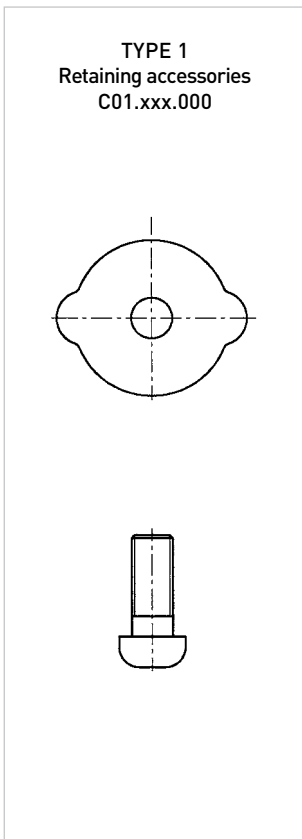
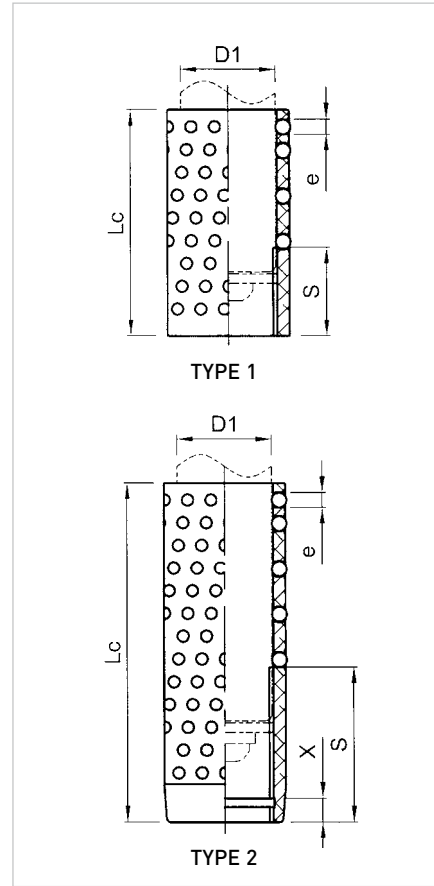
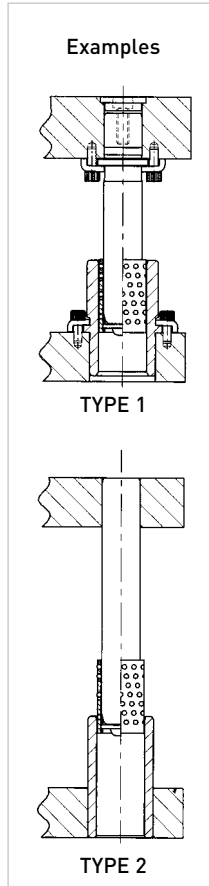
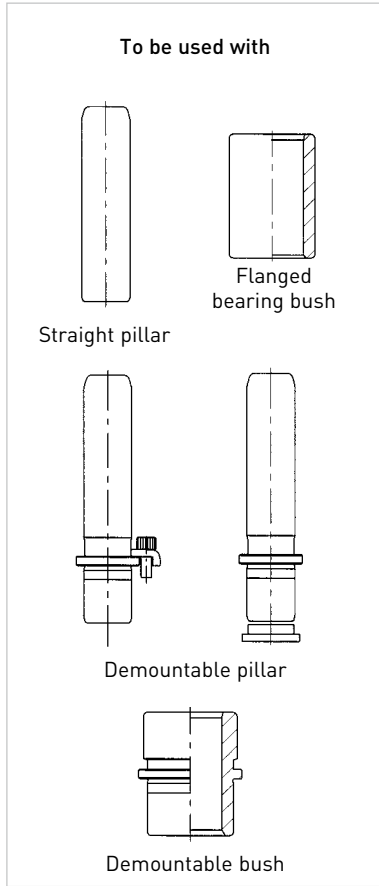

WORKING CONDITIONS

TYPE 1
In this case, the end of the pillar and the retaining washer may come out of the ball bearing cage. All of the ball bearings remain precompressed in contact with the pillar and bushes. The cage is supplied with a washer and screw. To select, please refer to p 24-25

TYPE 2
In this case the ball bearing cage may come out of the bush completely. At the lower end, the end of the pillar cannot leave the cage because the washer is stopped by the retaining ring. The cage is supplied with a washer, retaining ring and screw. To select, please refer to p 26-28

BALL BEARING CAGE

TYPE 1 & 2

C11

C12

D1		24	25	30	32	38
Lc	S	TYPE 1 BALL BEARING CAGE REFERENCE				
36	11,5	C11.024.036	C11.025.036	C11.030.036	C11.032.036	
48	17,5	C11.024.048	C11.025.048	C11.030.048	C11.032.048	C11.038.048
60	23,5					C11.038.060

Lc	S	TYPE 2 BALL BEARING CAGE REFERENCE				
55	27	C12.024.055	C12.025.055			
70	35	C12.024.070	C12.025.070	C12.030.070	C12.032.070	
	36					C12.038.070
85	43					C12.038.085
90	42	C12.024.090	C12.025.090			
	43			C12.030.090	C12.032.090	
100	50	C12.024.100	C12.025.100			
105				C12.030.105	C12.032.105	
	51					C12.038.105
110	60	C12.024.110	C12.025.110			
115				C12.030.115	C12.032.115	
	61					C12.038.115
125	70			C12.030.125	C12.032.125	
	71					C12.038.125
135	80			C12.030.135	C12.032.135	
	81					C12.038.135
145	91					C12.038.145
155	103					C12.038.155
X		4,2				5,8
e		4				

D1		40	48	50	63	80
Lc	S	TYPE 1 BALL BEARING CAGE REFERENCE				
48	17,5	C11.040.048				
60	23,5	C11.040.060				
70	28,5		C11.048.070	C11.050.070		
84	35,5		C11.048.084	C11.050.084		
98	42,5				C11.063.098	C11.080.098

Lc	S	TYPE 2 BALL BEARING CAGE REFERENCE				
70	36	C12.040.070				
85	43	C12.040.085				
105	51	C12.040.105	C12.048.105	C12.050.105		
		C12.040.115				
120	61		C12.048.120	C12.050.120		
125	71	C12.040.125				
135	81	C12.040.135				
140	71		C12.048.140	C12.050.140		
145	72				C12.063.145	C12.080.145
	91	C12.040.145				
150	81		C12.048.150	C12.050.150		
155	103	C12.040.155				
160	91		C12.048.160	C12.050.160		
165	82				C12.063.165	C12.080.165
170	103		C12.048.170	C12.050.170		
180	92				C12.063.180	C12.080.180
185	116		C12.048.185	C12.050.185		
190	105				C12.063.190	C12.080.190
195	128		C12.048.195	C12.050.195		
205	117				C12.063.205	C12.080.205
215	130				C12.063.215	C12.080.215
X		5,8	7,0			8,5
e		4	6			

DEMOUNTABLE ROUND OR SQUARE STEEL BLOCK

R05
R06
R07
R08

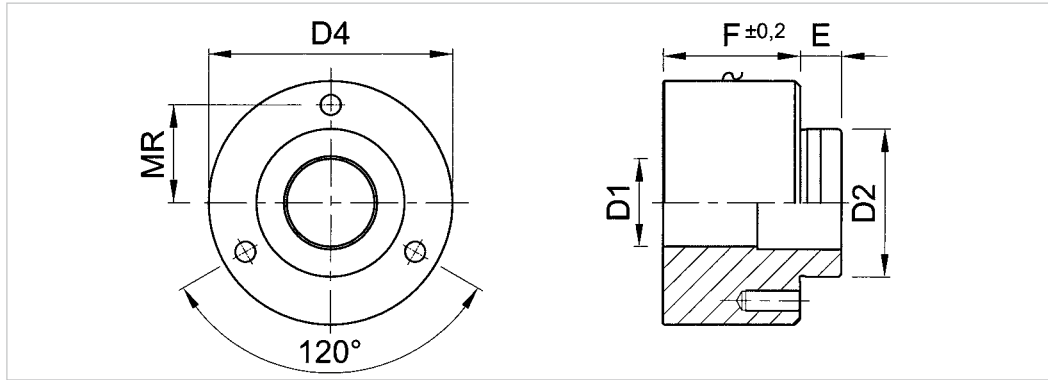

D1	32	40	50	63	80
F	REFERENCE FOR DEMOUNTABLE PILLAR STEEL BLOCK				
40	R05.032.040				
50	R05.032.050				
63		R05.040.063			
80		R05.040.080	R05.050.080		
100			R05.050.100	R05.063.100	
125				R05.063.125	R05.080.125
F	REFERENCE FOR DEMOUNTABLE BUSH STEEL BLOCK				
40	R06.032.040				
50	R06.032.050				
63		R06.040.063			
80		R06.040.080	R06.050.080		
100			R06.050.100	R06.063.100	
125				R06.063.125	R06.080.125

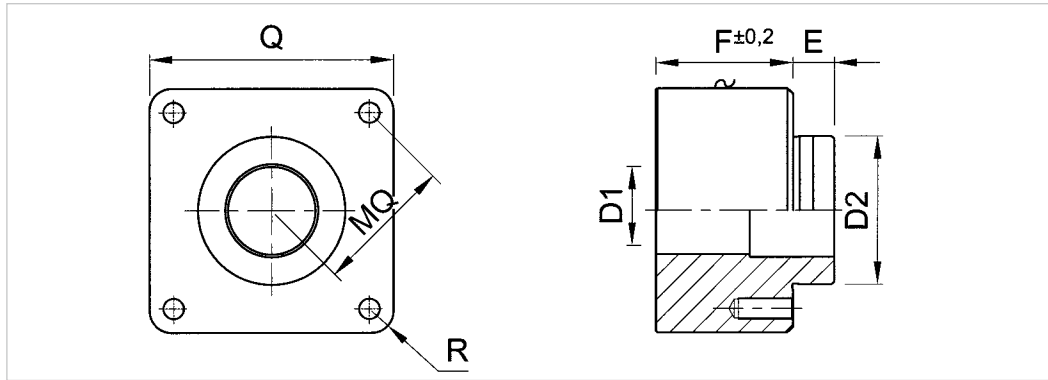

D1	32	40	50	63	80
F	REFERENCE FOR DEMOUNTABLE PILLAR STEEL BLOCK				
40	R07.032.040				
50	R07.032.050				
63		R07.040.063			
80		R07.040.080	R07.050.080		
100			R07.050.100	R07.063.100	
125				R07.063.125	R07.080.125
F	REFERENCE FOR DEMOUNTABLE BUSH STEEL BLOCK				
40	R08.032.040				
50	R08.032.050				
63		R08.040.063			
80		R08.040.080	R08.050.080		
100			R08.050.100	R08.063.100	
125				R08.063.125	R08.080.125
DIMENSIONS					
D2	54	65	81	100	118
D4=Q	89	102	114	140	165
E	15				
MR	35,75	41,75	48,75	60	70,75
MQ	48,79	55,15	59,40	77,78	88,39
Screw	M6			M8	

Fitting the demountable steel blocks

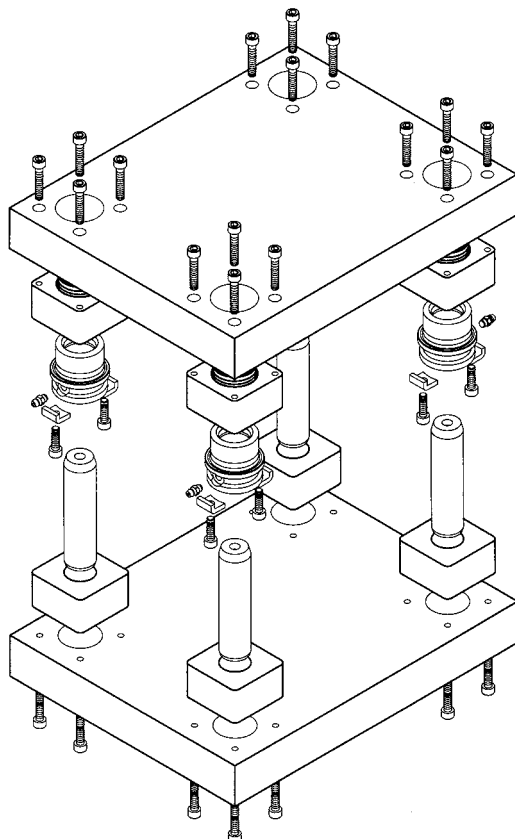
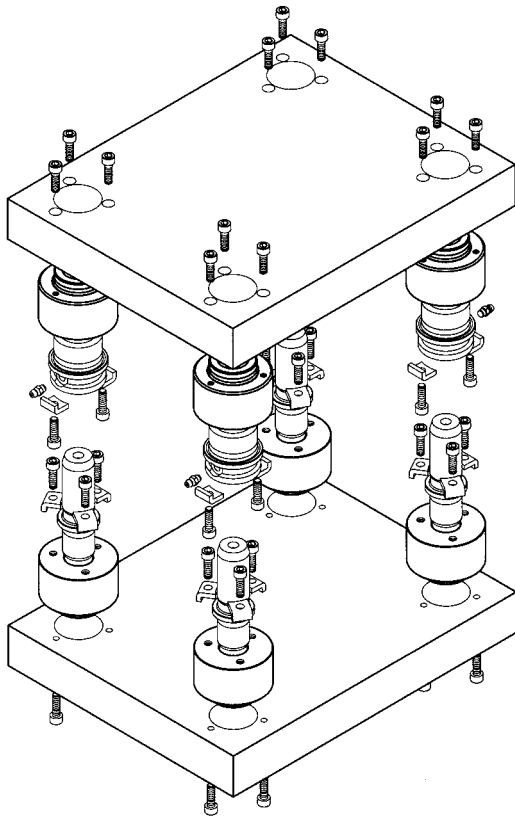

To be used with



Straight pillar

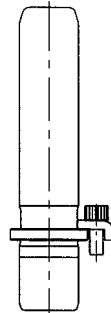

Demountable pillar

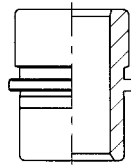

Demountable bush

Examples

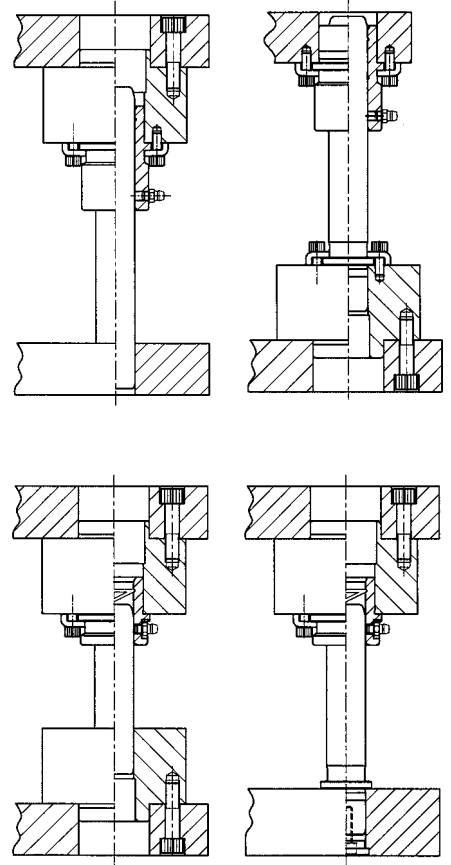

MAIN ADVANTAGES AND OBSERVATIONS

- 1 • The insertion method for the demountable steel blocks allows precise positioning in the bore without using pins and offers improved overall rigidity.
- 2 • The demountable steel blocks are interchangeable within the same product reference, allowing them to be swapped during dismantling and reassembly operations without affecting the performance of the tool.
- 3 • They are made from rolled carbon steel in round or square sections and are available in different standard thicknesses. Intermediate thicknesses are available upon request for a price supplement.

Please note :

- Diameter D1 corresponds to the nominal diameter of the pillar.
- The screw lengths must be determined according to the thickness of the plates to which the extensions will be fitted.
- The extensions may be used with the ball bearing guide system. Please contact us for help with any of your questions.

Ordering example

Round bush extensions; D1=40 mm; F=80 mm
R06.040.080

NOTES

A large rectangular area with horizontal dotted lines, intended for taking notes.

NOTES

Blank lined area for notes.

ASSEMBLY INSTRUCTIONS

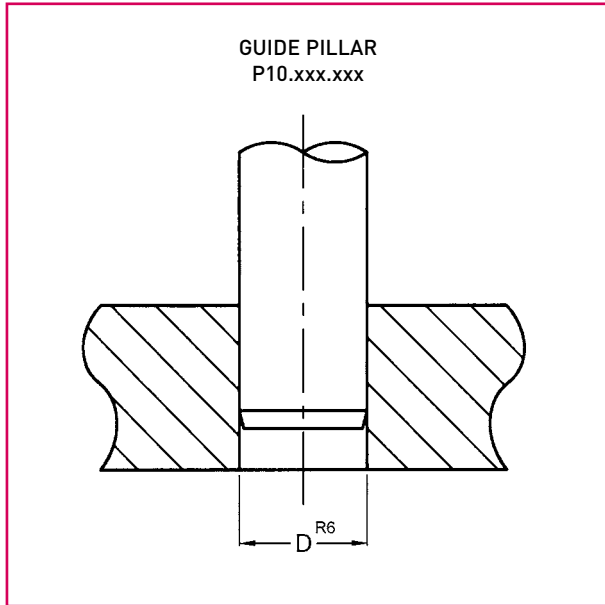

Pillar diameter D_1	Bore diameter D_{R6}	
19/20	19/20	-0,024 -0,037
24/25	24/25	-0,024 -0,037
30/32	30/32	-0,029 -0,045
38/40	38/40	-0,029 -0,045
48/50	48/50	-0,029 -0,045
63	63	-0,035 -0,054
80	80	-0,037 -0,056

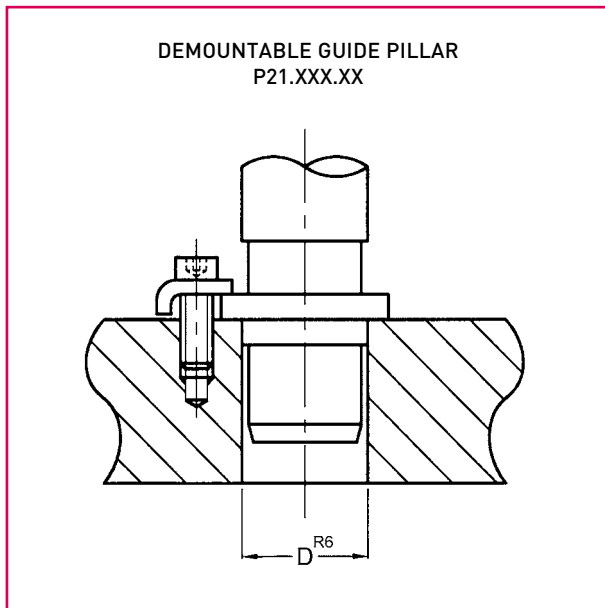

Pillar diameter D_1	Bore diameter D_{R6}		Adjustment Mini Maxi
19/20	-0,011 -0,020	19/20 -0,024 -0,037	-0,004 -0,026
24/25	-0,011 -0,020	24/25 -0,024 -0,037	-0,004 -0,026
30/32	-0,016 -0,025	30/32 -0,029 -0,045	-0,004 -0,029
38/40	-0,016 -0,025	38/40 -0,029 -0,045	-0,004 -0,029
48/50	-0,017 -0,029	48/50 -0,029 -0,045	0,000 -0,028
63	-0,017 -0,029	63 -0,035 -0,054	-0,006 -0,037
80	-0,017 -0,029	80 -0,037 -0,056	-0,008 -0,039

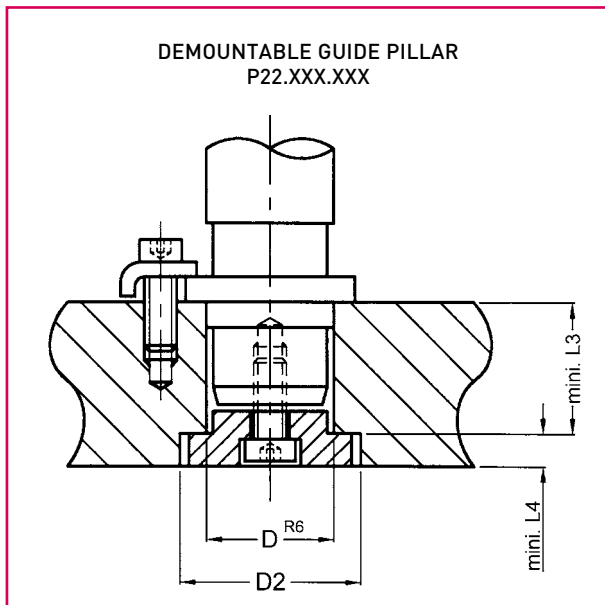

Pillar diameter D_1	Bore diameter D_{R6}		D_2	L_3	L_4
19/20	-0,011 -0,020	19/20 -0,024 -0,037	26	25	3,5
24/25	-0,011 -0,020	24/25 -0,024 -0,037	33	30	5,5
30/32	-0,016 -0,025	30/32 -0,029 -0,045	41	40	5,5
38/40	-0,016 -0,025	38/40 -0,029 -0,045	51	51	5,5
48/50	-0,017 -0,029	48/50 -0,029 -0,045	64	59	5,5
63	-0,017 -0,029	63 -0,035 -0,054	77	70	5,5
80	-0,017 -0,029	80 -0,037 -0,056	94	86	5,5

DEMOUNTABLE STEEL BUSHES B10.xxx.xxx

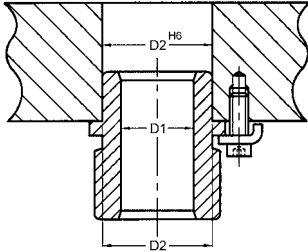

Nominal diameter D ₁	Bush diameter D ₂	Bore diameter D ₂ H ₆	Adjustment Mini Maxi
19/20	28 +0,021 +0,013	28 +0,013 +0,000	-0,000 -0,021
24/25	38 +0,025 +0,016	38 +0,016 +0,000	-0,000 -0,025
30/32	45 +0,025 +0,016	45 +0,016 +0,000	-0,000 -0,025
38/40	54 +0,030 +0,019	54 +0,019 +0,000	-0,000 -0,030
48/50	65 +0,030 +0,019	65 +0,019 +0,000	-0,000 -0,030
63	81 +0,035 +0,022	81 +0,022 +0,000	-0,000 -0,035
80	100 +0,035 +0,022	100 +0,022 +0,000	-0,000 -0,035

STRAIGHT SLEEVE BALL BEARING BUSHES B30.xxx.xxx

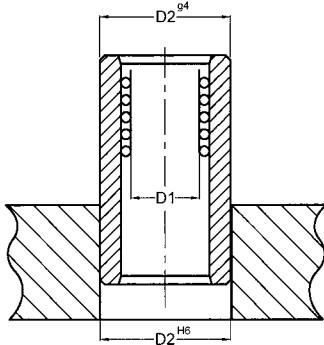

Nominal diameter D ₁	Bush diameter D ₂ g ₄	Bore diameter D ₂ H ₆	Adjustment Mini Maxi
24/25	45 -0,009 -0,016	45 +0,016 +0,000	+0,009 +0,032
30/32	54 -0,010 -0,018	54 +0,019 +0,000	+0,010 +0,037
38/40	65 -0,010 -0,018	65 +0,019 +0,000	+0,010 +0,037
48/50	81 -0,012 -0,022	81 +0,022 +0,000	+0,012 +0,044
63	95 -0,012 -0,022	95 +0,022 +0,000	+0,012 +0,044
80	112 -0,012 -0,022	112 +0,022 +0,000	+0,012 +0,044

DEMOUNTABLE BALL BEARING BUSHES B40.XXX.XXX / B42.XXX.XXX

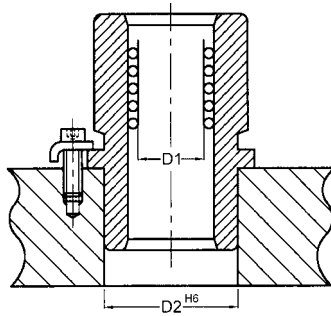

Nominal diameter D ₁	Bush diameter D ₂	Bore diameter D ₂ H ₆	Adjustment Mini Maxi
24/25	45 +0,025 +0,016	45 +0,016 +0,000	-0,000 -0,025
30/32	54 +0,030 +0,019	54 +0,019 +0,000	-0,000 -0,030
38/40	65 +0,030 +0,019	65 +0,019 +0,000	-0,000 -0,030
48/50	81 +0,035 +0,022	81 +0,022 +0,000	-0,000 -0,035
63	95 +0,035 +0,022	95 +0,022 +0,000	-0,000 -0,035
80	112 +0,035 +0,022	112 +0,022 +0,000	-0,000 -0,035

PILLAR/BUSH EXTENSION R0x.xxx.xxx

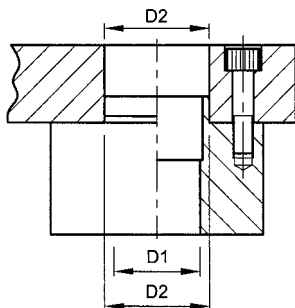

Nominal diameter D ₁	Extension diameter D ₂	Bore diameter D ₂ H ₆	Adjustment Mini Maxi
32	54 +0,030 +0,019	54 +0,019 +0,000	-0,000 -0,025
40	65 +0,030 +0,019	65 +0,019 +0,000	-0,000 -0,030
50	81 +0,035 +0,022	81 +0,022 +0,000	-0,000 -0,035
63	100 +0,035 +0,022	100 +0,022 +0,000	-0,000 -0,035
80	118 +0,035 +0,022	118 +0,022 +0,000	-0,000 -0,035

TYPE 1: THE CAGE IS COMPLETELY PRELOADED THROUGHOUT THE ENTIRE STROKE

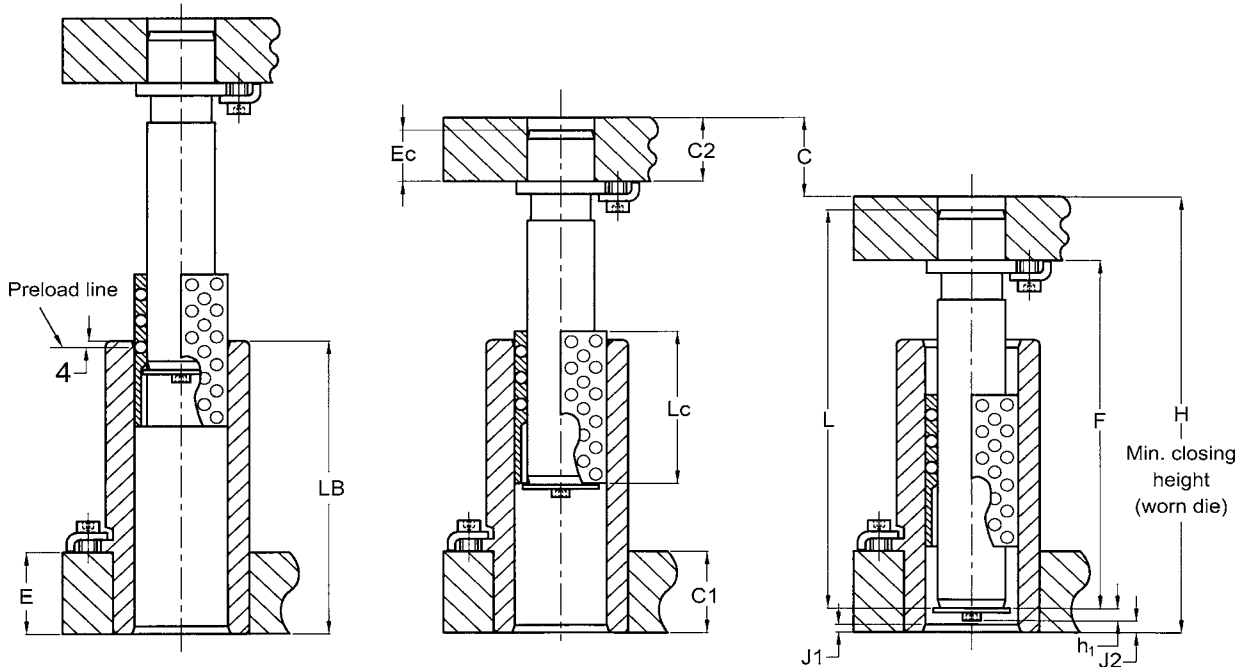

Unit in the assembly position:
Ball bearing cage suspended on the tabs
of the retaining washer.

Unit at the top of the stroke position.

Unit at the bottom of the stroke.

CALCULATING THE LENGTH OF THE PILLARS

- Use of B30.xxx.xxx bush

$$L \text{ pillar type P10} = H - h_1 - J_2 - C_2 + Ec$$

$$F \text{ pillar type P21} = H - h_1 - J_2 - C_2$$

- Use of B40.xxx.xxx bush

$$L \text{ pillar type P10} = H - h_1 - J_1 - C_1 + E - C_2 + Ec$$

$$F \text{ pillar type P21} = H - h_1 - J_1 - C_1 + E - C_2$$

- H = Min. closing height
h1 = Height of nut + washer at base of pillar
J2 = Safety margin at end of stroke (B30 bush)
C2 = Thickness of top plate
Ec = Depth of insertion for straight pillar
J1 = Safety margin at end of stroke (B40 flanged bearing bush)
C1 = Thickness of bottom plate
E = Depth of insertion for B40 bush

Refer to Page 28 for values E, h, J1 and J2

The choice of a Type 1 bushing and ball cage unit is based upon the required stroke and the nominal diameter of the pillar.

When these two measurements are known, choose the components by referring to the table opposite.

- Choose the required stroke from the "Stroke C" column.
- Follow this column down until you come to the coloured box situated in the row corresponding to the required pillar diameter.
- You will find the required length of bush on the same row, in column L_B .
- Choose the required length of ball bearing cage from column LC. The longer the ball bearing cage, the longer its life span. Verify that the die closing height allows for this choice.
- See above to calculate the pillar lengths.

ELEMENT SELECTION

BALL BEARING GUIDE • TYPE 1

Nominal pillar dia.	Bush length	Cage length	Stroke C (worn die and punch)			
			10	50	100	150
D _n	L _B	L _c				
24/25	65	36	█			
	80	36	█	█		
	95	36	█	█		
	110	36	█	█		
	130	48	█	█	█	
30/32	80	36	█	█		
	95	36	█	█		
	110	36	█	█		
	130	36	█	█	█	
	150	36	█	█	█	
	170	48	█	█	█	█
38/40	80	48	█	█		
	95	48	█	█		
	110	48	█	█		
	130	48	█	█	█	
	150	48	█	█	█	
	170	48	█	█	█	█
	190	48	█	█	█	█
215	60	█	█	█	█	
48/50	110	70	█	█		
	130	70	█	█		
	150	70	█	█		
	170	70	█	█	█	
	190	70	█	█	█	█
	215	70	█	█	█	█
	240	70	█	█	█	█
265	84	█	█	█	█	
63	150	98	█	█		
	170	98	█	█		
	190	98	█	█		
	215	98	█	█	█	
	240	98	█	█	█	█
	265	98	█	█	█	█
80	150	98	█	█		
	170	98	█	█		
	190	98	█	█		
	215	98	█	█	█	
	240	98	█	█	█	█
	265	98	█	█	█	█

GUIDE ELEMENT SELECTION

BALL BEARING • TYPE 2

TYPE 2: THE BALL BEARING CAGE IS NO LONGER PRELOADED

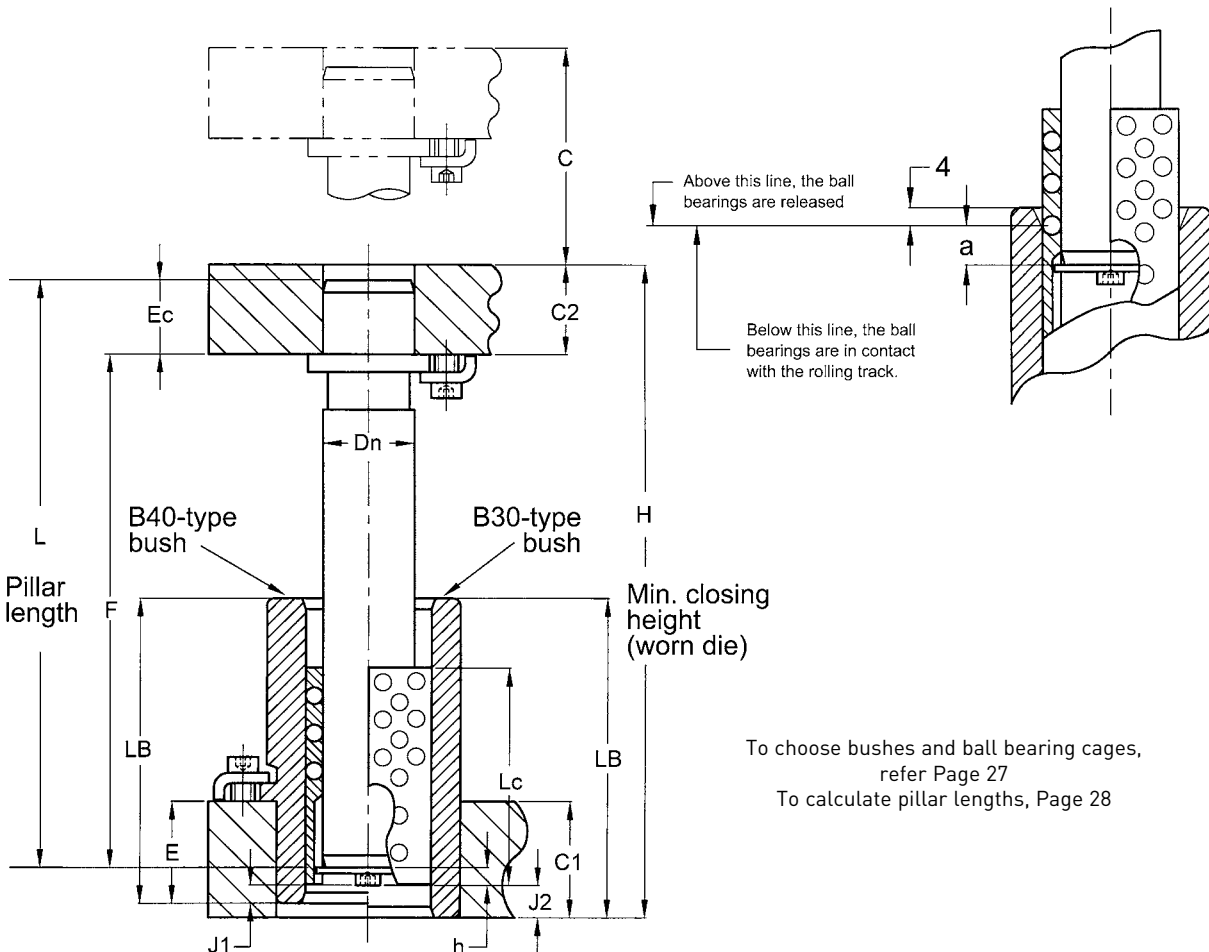
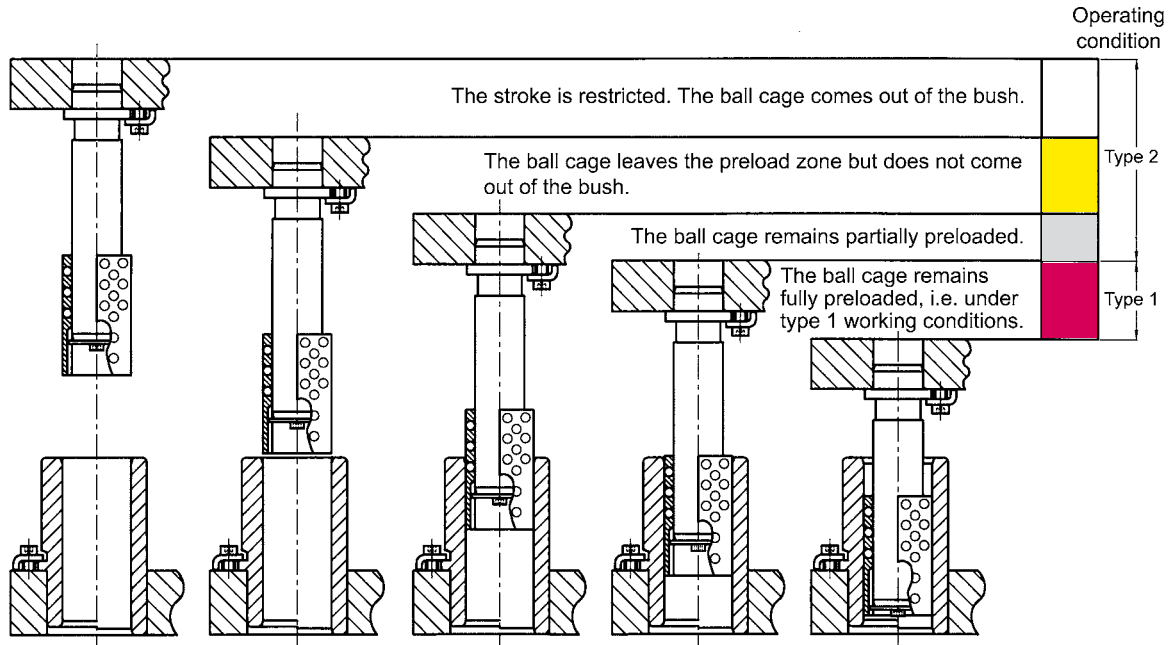

GUIDE ELEMENT SELECTION

BALL BEARING • TYPE 2

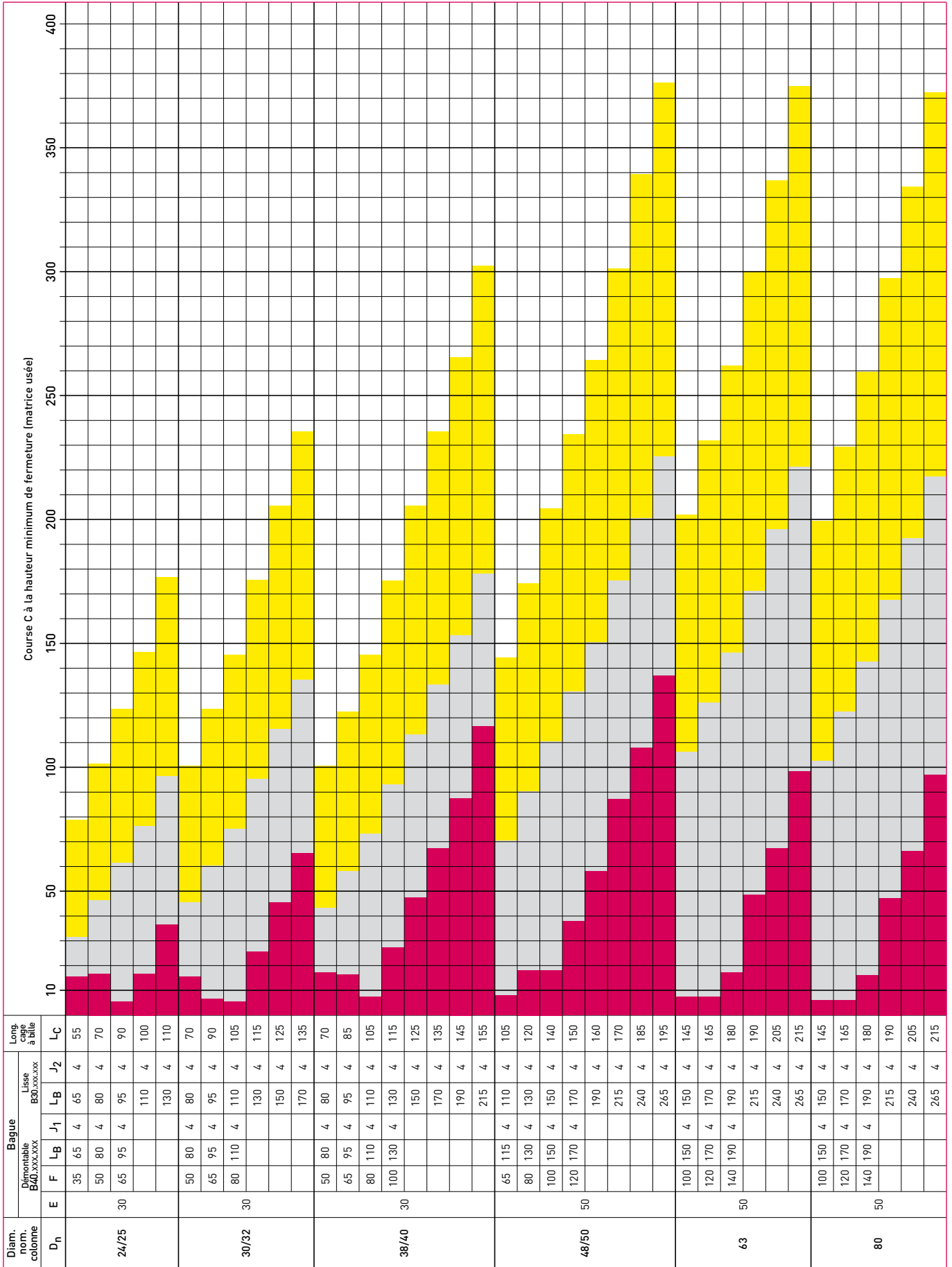

CALCULATING THE PILLAR LENGTH

Use of bush B30.xxx.xxx

L pillar type P10 = $H - h_2 - J_2 - C_2 + E_c$

F pillar type P21 = $H - h_2 - J_2 - C_2$

Use of bush B40.xxx.xxx

L pillar type P10 = $H - h_2 - J_1 - C_1 + E - C_2 + E_c$

F pillar type P21 = $H - h_2 - J_1 - C_1 + E - C_2$

If the correct length of guide pillar does not exist :

For the P10 type
or

- Choose a guide pillar of next length up and cut it down to length L,
- Choose a guide pillar of the next shortest length and place it in the punch plate in such a way that you obtain length L

For the P21 type

For the P22 type

- Adjust the dimension C_2 in order to obtain J_2 and h_2 at the lowest point.
- Position bush B30 in order to obtain J_2 and h at the lowest point.

H =	Min. closing height
h ₂ =	Height of nut + washer at base of pillar
J ₂ =	Safety margin at end of stroke (B30 bush)
C ₂ =	Thickness of top plate
E _c =	Depth of insertion for straight pillar
J ₁ =	Safety margin at end of stroke (B40 flanged bearing bush)
C ₁ =	Thickness of bottom plate
E =	Depth of insertion for B40 bush

ENSEMBLE BAGUE + CAGE À BILLES

To choose a type 2 ball bearing bushing unit, you must first determine the required length of stroke C, and the diameter of the pillar. Next, determine the operating conditions (see Page 24-27).

When these three factors are known, refer to the selection table on Page 27. Go to the column with the stroke C required. Follow this column down until you are level with the required diameter D_n and find the box corresponding to the desired operating conditions.

The longest ball bearing bush allowed by the closing height will have the longest service life.

When you have found the corresponding coloured box, follow the horizontal line towards the right-hand side to select the correct lengths of bush and ball bearing cage. See the previous page to calculate the pillar length.

When you have determined all of these measurements, refer to the pages giving all of the dimensions and reference numbers for the different parts.

Nominal pillar Ø D _n	a	h ₁	h ₂	J ₁ =J ₂	E
24/25	14,5	5,8	9,3	4	30
30/32	14	6,9	10,4	4	30
38/40	14,5	8	11,5	4	30
48/50	15,5	9,1	12,6	4	50
63	15,5	12,5	16	4	50
80	15,5	15	18,5	4	50

BADLLI EB EFUALRLIYN GO PCEANGE IS IN POSITIOSNA FEINT YT HZEO NPERE (LBOA).D AND

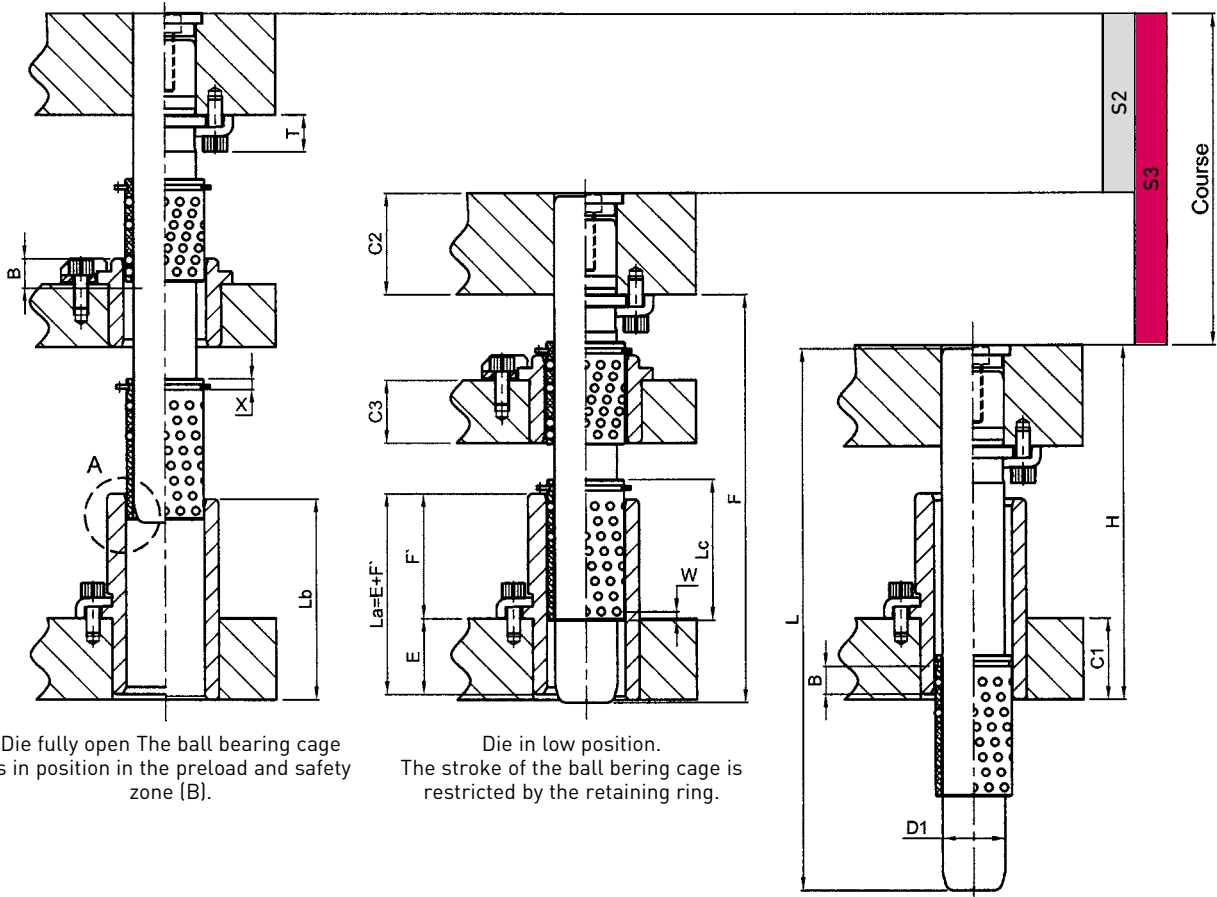

Die fully open The ball bearing cage is in position in the preload and safety zone (B).

Die in low position. The stroke of the ball bearing cage is restricted by the retaining ring.

Die in maximum position. Die with ball bearing cage without retaining ring and without stripper plate.

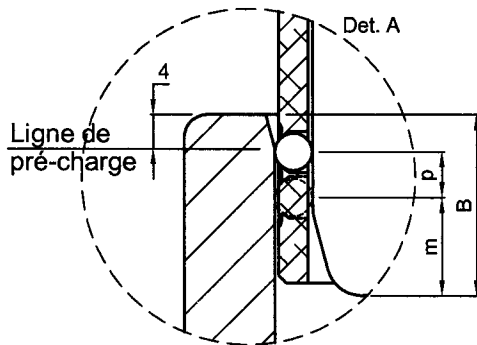

CALCULATION OF STROKES S2 AND S3 WITH TYPE 3 BALL BEARING CAGE.

$$S2 = 2 (Lc - X - W - B)$$

$$S3 = (Lc - X - W + La \text{ ou } Lb) - 4 (B)$$

- H = Min. closing height
- La = Length of demountable bush (type B4x.xxx.xxx)
- Lb = Length of demountable bush (type B30.xxx.xxx)
- Lc = Length of ball bearing cage (type C13.xxx.xxx)
- p = Pitch of rows of ball bearings (ball bearing cage type C13.xxx.xxx)
- m = Entry taper of pillar
- B = Safety height for bearings when preloaded

Technical data :
Values La, E and F' : See pages 13-14
Lb values : voir page 12
Lc values : voir page 15

D1	24	25	30	32	38	40	48	50	63	80
X	4,2		4,9		5,7		6,7			
W	5		5,3		4,8		5,6			
B	20,1				21,1		22,8		23,6	24,8

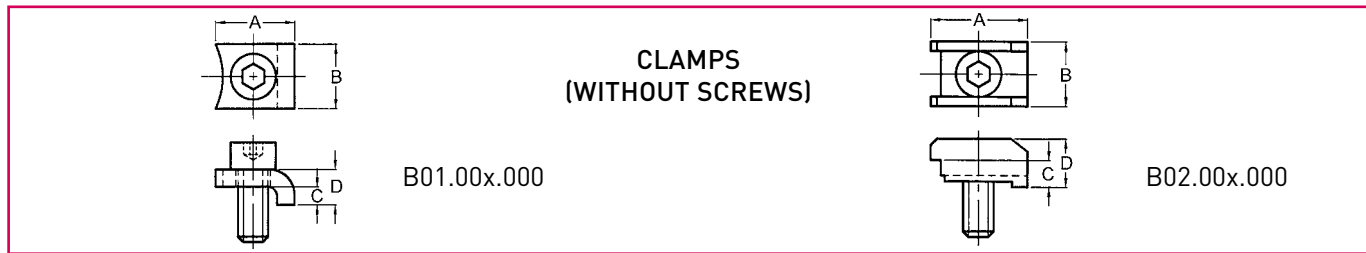

ACCESSORIES

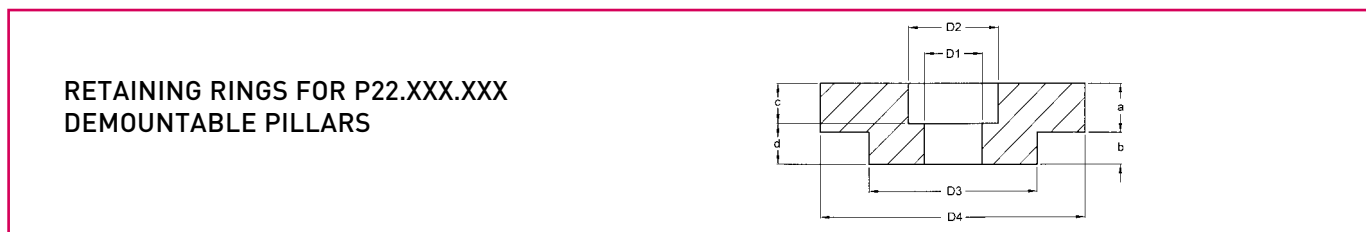

Ref.	B01.005.000	B01.006.000	B01.008.000	B02.006.000	B02.008.000
A	12,3	14,3	19,8	18,3	24,6
B	12,7	15,9	15,9	14,5	18,8
C	3,2	4,9	4,9	5	5
D	5,6	8,7	9,5	10	13
Ø screw	M5	M6	M8	M6	M8

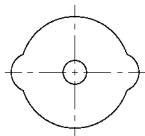
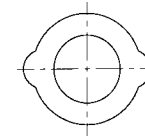
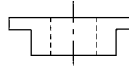

Nominal pillar Ø Dn	19	20	24	25	30	32	38	40	48	50	63	80
D1	5,6		6,8		8,8		10,8		12,8		17	21
D2	9,7		11,2		14,2		17,2		19,2		25,5	31,5
D3	19		24		30		38		48		63	80
D4	25		32		40		50		63		76	93
a	3,3		5		5		5		5		5	5
b	4,2		4		7		10		13		19	25
c	5	—	6		8		10		12		16	20
d	2,5		3		4		5		6		8	10
Ref.	P02.020.000		P02.025.000		P02.032.000		P02.040.000		P02.050.000		P02.063.000	P02.080.000

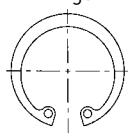
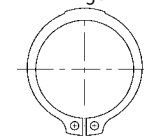
	Retaining washer TYPE 1	Retaining washer TYPE 2	Lockwasher TYPE 2	Mounting screw	TYPE 2 Retaining rings	TYPE 3 Retaining rings
				 ISO 7380 for Ø 24 to 50 DIN 7984 for Ø 63		
Nominal pillar Ø Dn	TO BE USED FOR SETS					
	TYPE 1	TYPE 2	TYPE 2	TYPE 1 - 2	TYPE 2	TYPE 3
24	C01.024.001	C02.024.001	C02.025.002	M 6 x 20	C02.024.003	C03.024.032
25	C01.025.001	C02.025.001			C02.025.003	C03.025.033
30	C01.030.001	C02.030.001	C02.032.002	M 8 x 20	C02.030.003	C03.030.038
32	C01.032.001	C02.032.001			C02.032.003	C03.032.040
38	C01.038.001	C02.038.001	C02.040.002	M 10 x 25	C02.038.003	C03.038.046
40	C01.040.001	C02.040.001			C02.040.003	C03.040.048
48	C01.048.001	C02.048.001	C02.050.002	M 12 x 30	C02.048.003	C03.048.060
50	C01.050.001	C02.050.001			C02.050.003	C03.050.062
63	C01.063.001	C02.063.001	C02.063.002	M 16 x 35	C02.063.003	C03.063.001
80	C01.080.001	C02.080.001	C02.080.002	M 20 x 40	C02.080.003	C03.080.091

Area for handwritten notes with horizontal dotted lines.

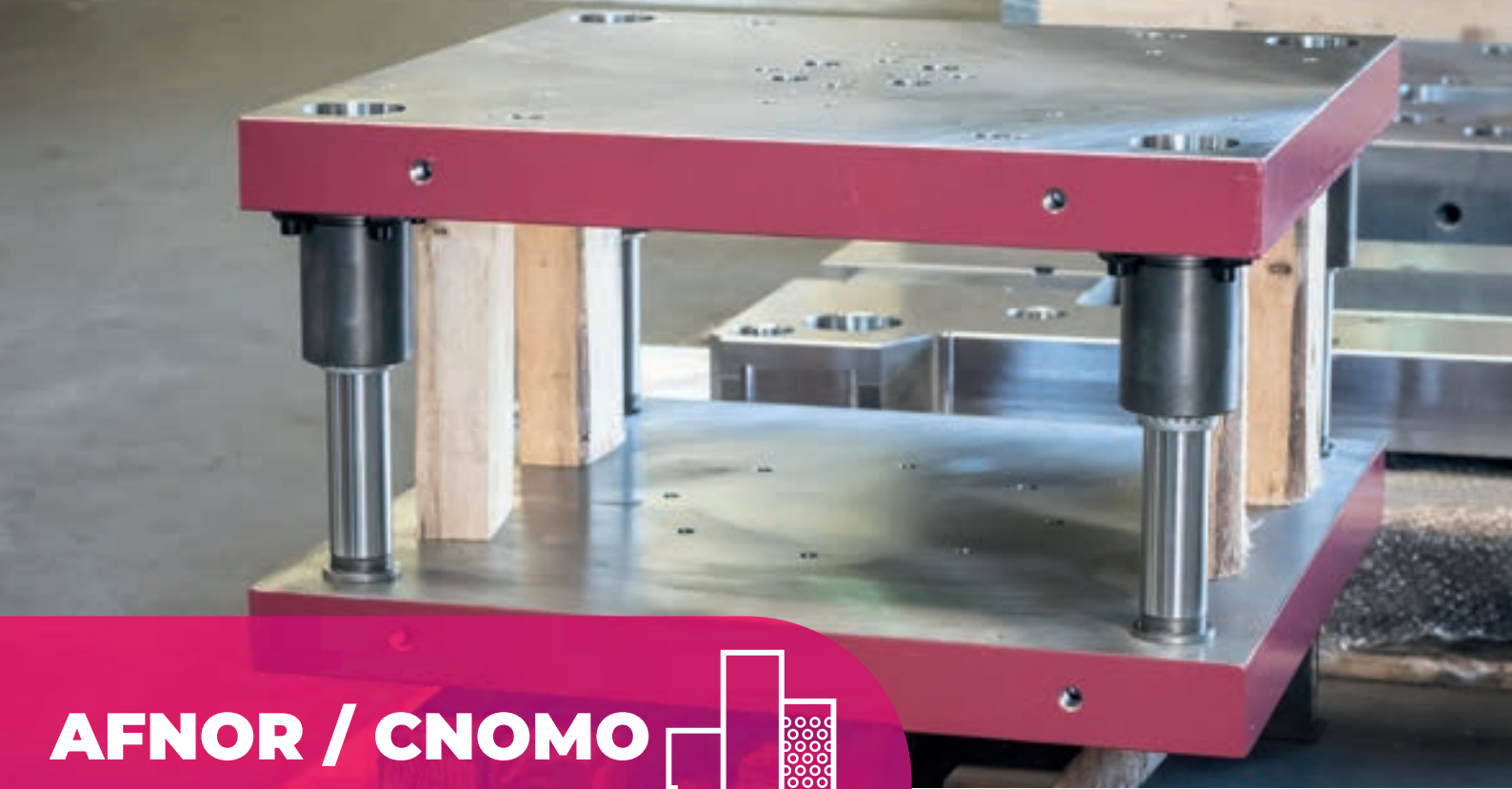

**AFNOR / CNOMO
STANDARD**







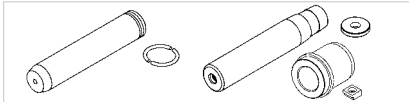

Guiding elements

MDL[®]

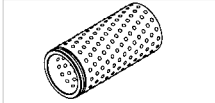
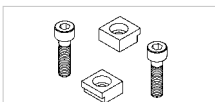
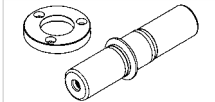
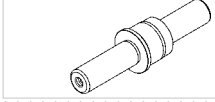

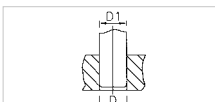
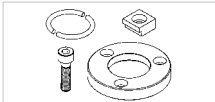
AMDL[®]
Atelier Mécanique De La Lauch

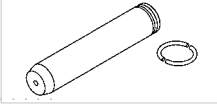
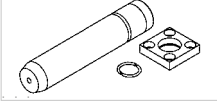
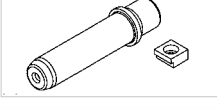
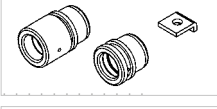
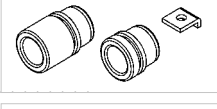
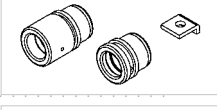
■ General information			150
■ Ordering example			152
■ Guide pillar		CA EB BA	154
■ Guide bush		HB JB NB GB	155
■ Ball bearing cage		PA	156
■ Strokes			157
■ Clamp positions			158
■ Demountable pillar		EPO	159
■ Middle pillar		CMF	160
■ Retaining bush		BAD	161
■ Assembly tolerances			162
■ Accessories			163

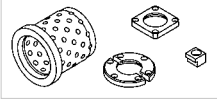
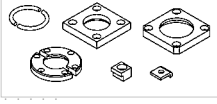
■ Guide Pillar, 1/2 snap-ring lower clamping		RI	165
■ Guide Pillar, 1/2 snap-rings medium clamping		RM	166
■ Disassembling guide pillar with fixing clamps		RID	167
■ Bronze Guide Bush with collar		BRO	168
■ «Aluanodised» Guide Bush with collar		ALU	169
■ Steel Guide Bush with collar		ACI	170
■ Prive Fit Bronze Guide Bush with collar		BCA	171
■ Bronze demountable Guide Bush with Graphite Inserts		BBEI	172
■ Accessories (P01-B03-BC-B05-BDR-BRCB)			173-174

DESCRIPTION OF "GUIDABILLE"® BALL BEARING GUIDES - GB Standard

The "GUIDABILLE" is a guide element that allows the following movements:
TRANSLATION and ROTATION, plus SIMULTANEOUS TRANSLATION and ROTATION.

These movements are performed with negligible energy expenditure (very low coefficient of friction: between 0.0009 and 0.0015).

THE "GUIDABILLE" HAS THREE MAIN COMPONENTS

ONE PILLAR made from 13-chrome steel, core-hardened, ground between centres and superfinished, offering very high wear and impact-resistance (62-64 HRC).

This pillar can be: DEMOUNTABLE: with a tapered shank.
 FIXED: by force-fitting on a press.

ONE BALL BEARING CAGE, consisting of :

- One bronze bush (to prevent oxidation)
- High-precision ball bearings made from the highest quality steel:
- The spiral configuration means that each ball bearing has its own roller track, thus evenly distributing the loads throughout the pillar.

ONE GUIDE BUSH made from high-strength bearing steel that has been tempered, ground and polished.

ADVANTAGES

Extremely accurate guiding.

For applications with high stroke rates.

Operates at both high and low speeds with virtually no friction and no need for maintenance.

Minimal wear due to the use of high-strength steel.

RENARD SERIES standardised dimensions.

We keep large stocks for immediate deliveries.

APPLICATIONS

Originally designed for die sets, the "GUIDABILLE" is also used in numerous applications in all industries:

- As STANDARDISED PARTS - the subject of this catalogue.
- As SPECIALLY DESIGNED PARTS, upon request.

PILLARS INSERTED INTO THE BASE PLATE

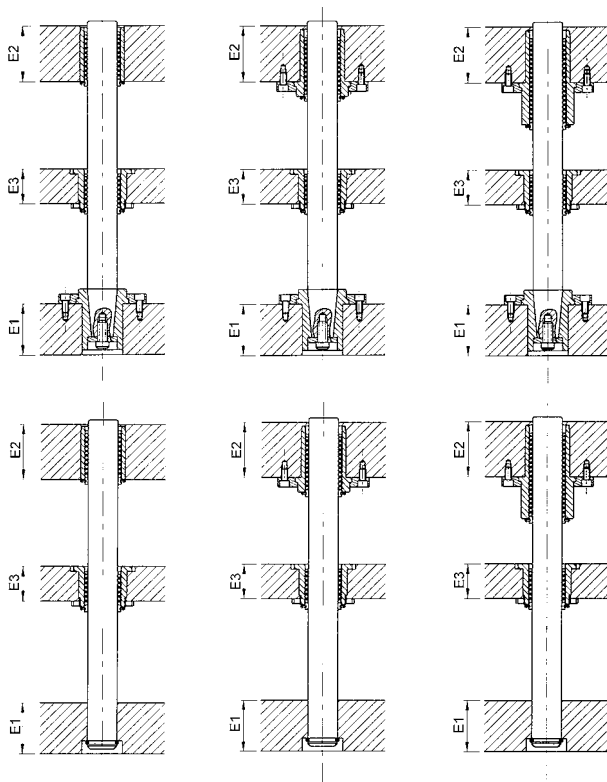

PILLARS INSERTED INTO THE TOP PLATE

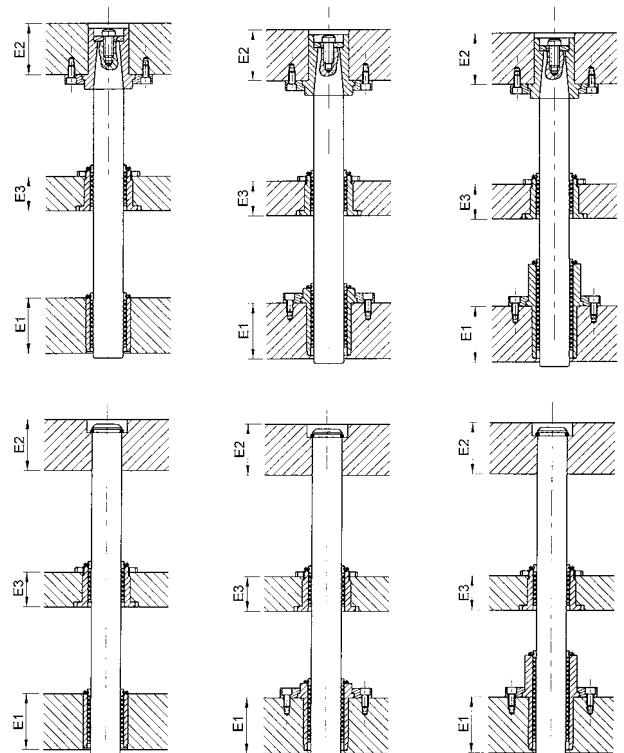

GENERAL INFORMATION

MATCHING OF BUSHES AND PILLARS

By matching bushes and pillars, we can offer you three adjustment categories:

- CATEGORY 1**
 - For the cutting of very fine sheet metal.
 - For clearance between punch and die of less than 0.02 mm per side.
- CATEGORY 2**
 - For the cutting of sheet metal more than 0.4 mm thick
 - For clearance between punch and die of 0.02 to 0.06 mm per side.
 - For most applications.
- CATEGORY 3**
 - For clearance between punch and die of 0.08 mm per side.
 - For die-stamping tools.

To facilitate the identification of these three operating categories, our bushes and pillars have been colour-coded (in white, blue and yellow). The aforementioned categories are obtained by combining bushes and pillars (see graph below).

E.g. : for a $\varnothing 12$ guide, the preloading in Category 1 is between -3 and $-7 \mu\text{m}$. Category 1 can be obtained by combining a white pillar with a blue bush, or by combining a blue pillar with a yellow bush.

When ordering, please specify the desired category. If no information is given, your order will be delivered as a Category 2 item by default.

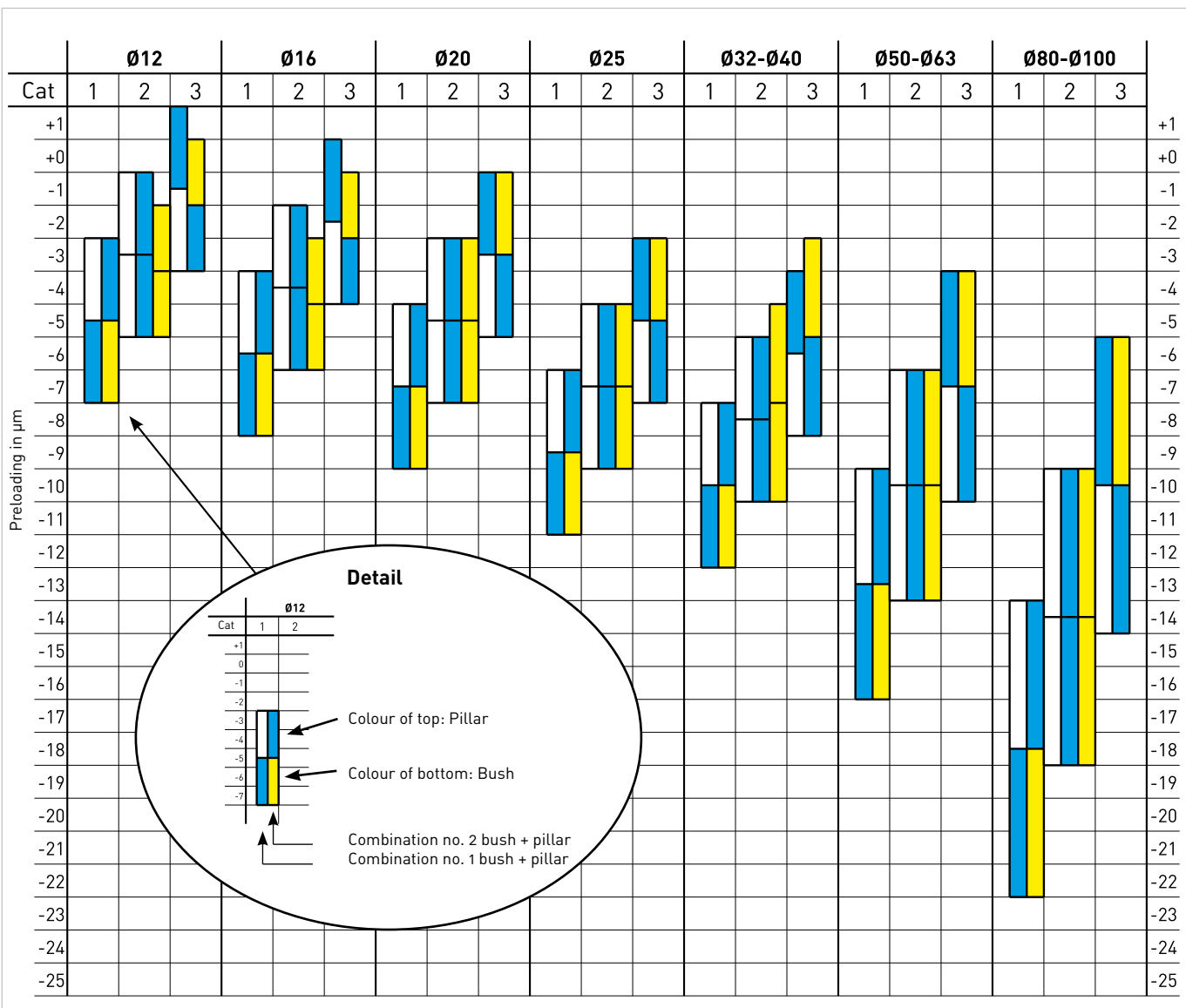

ORDERING EXAMPLES

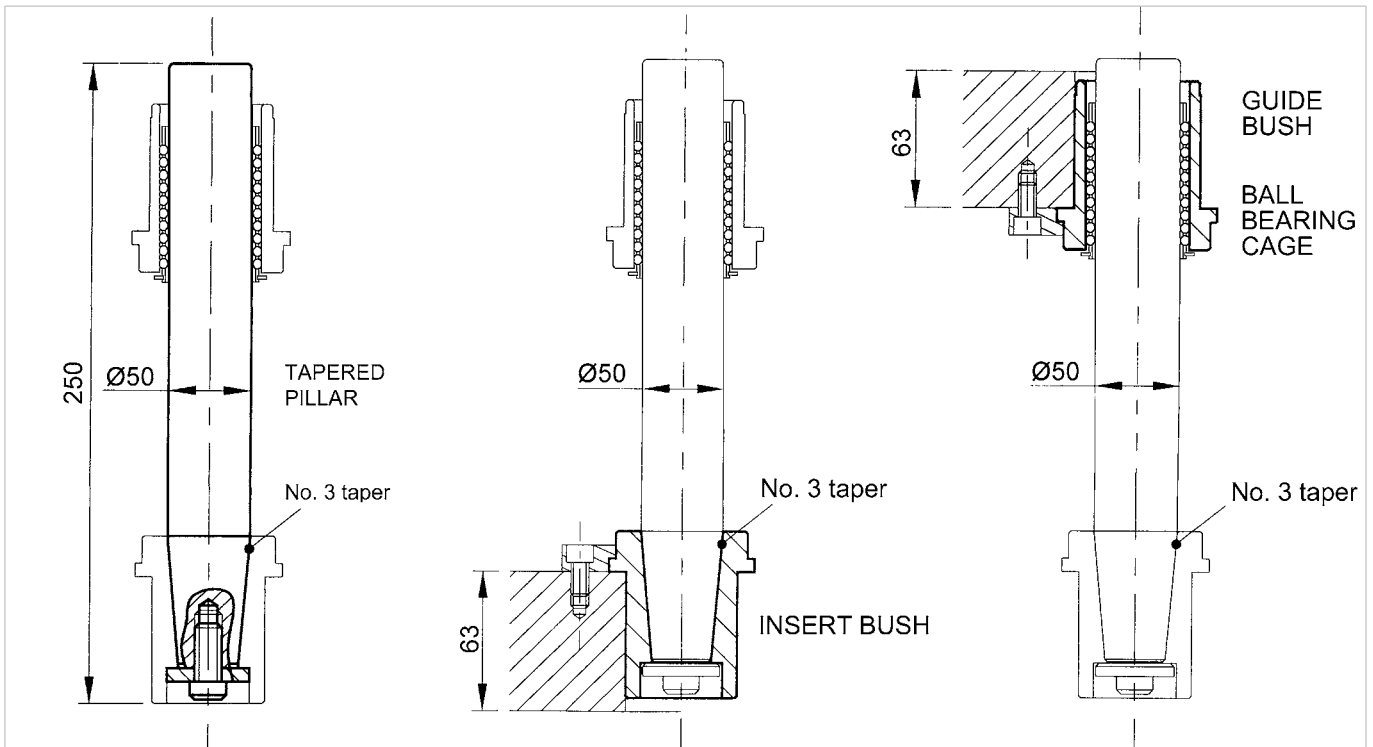

Ref. : **CA.050.250.3**

Ref. : **EB.050.063.3**

Ref. : **HB.050.063**
PA.050.10

To order 4 "Guidabilles", please state :

4	CA.050.250.3	4	PA.050.10
4	EB.050.063.3	16	B03.008.000 (mounting clamp)
4	HB.050.063		

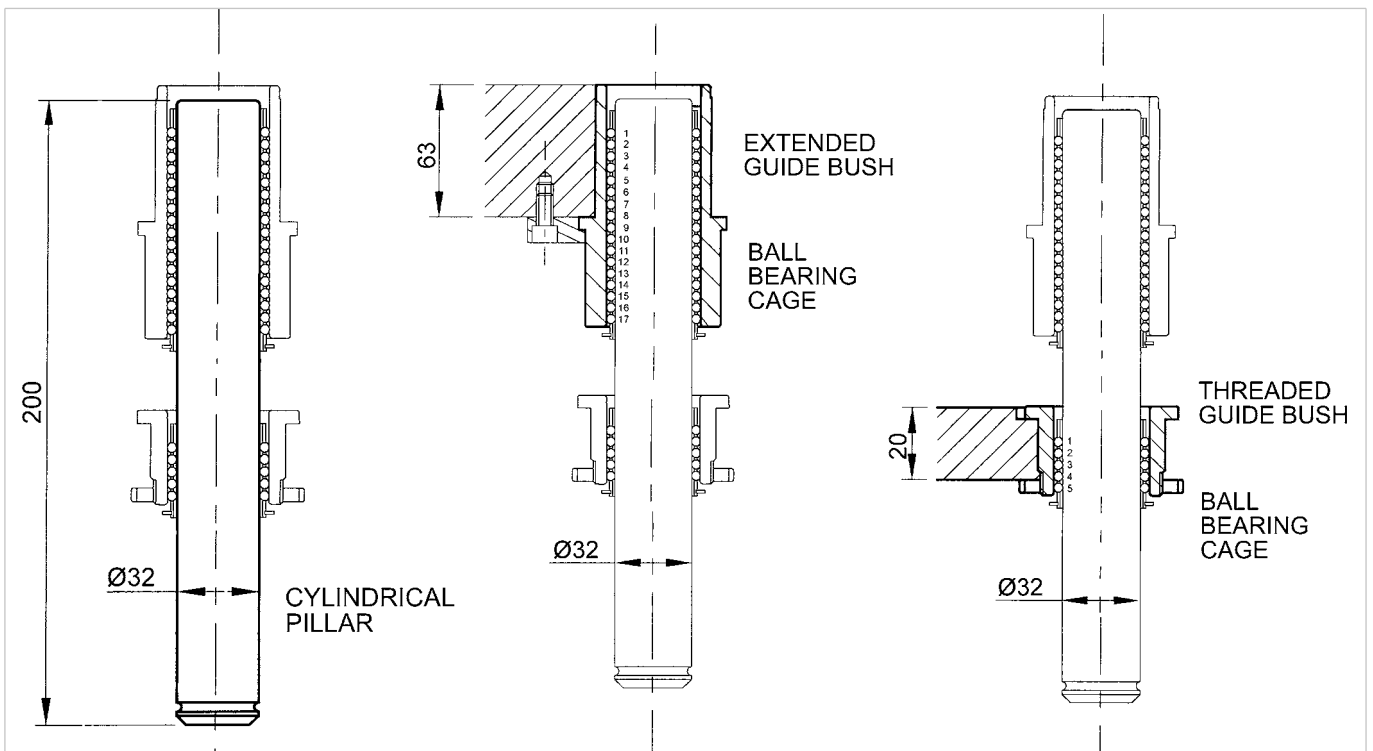

Ref. : **BA.032.200**

Ref. : **JB.032.050**
PA.032.17

Ref. : **NB.032.020**
PA.032.05

To order 2 "Guidabilles", please state :

2	BA.032.200	2	PA.032.17
2	JB.032.050	2	PA.032.05
2	NB.032.020	4	B03.006.000 (mounting clamp)

NOTES

A large rectangular area with horizontal dotted lines, intended for taking notes.



According to AFNOR standards NF E 63.120/121/122/123/124/125.

Please note

The reference indices for taper 1 - 2 or 3 [e.g. CA.040.250.2 and CA.040.250.3] mean that for the pillar in question, there are 2 taper lengths (2 and 3 respectively).
The pillars CA and bushes EB must have the same length of taper.
E.g. CA.040.250.3 with EB.040.050.3 or CA.040.250.2 with EB.040.063.2)

Important note

Some of these parts have MABEC codes.

Key for CA-type pillars

- On request
- Available in taper 1(x=1) and 2 (x=2)
- Available in taper 2 (x=2) and 3 (x=3)

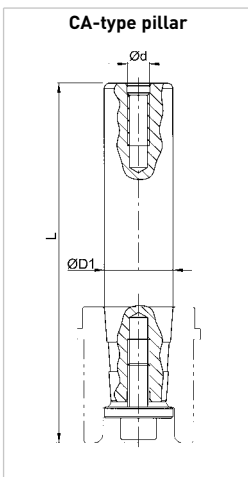

ØD1	12	16	20	25	32	40	50	63	80	100
L	REFERENCE									
100	CA.012.100.1									
110	CA.012.110.1	CA.016.110.1								
125	CA.012.125.1	CA.016.125.1	CA.020.125.1							
140		CA.016.140.1	CA.020.140.1	CA.025.140.x						
160		CA.016.160.1	CA.020.160.1	CA.025.160.x	CA.032.160.x					
180		CA.016.180.1	CA.020.180.1	CA.025.180.x	CA.032.180.x	CA.040.180.x				
200		CA.016.200.1	CA.020.200.1	CA.025.200.x	CA.032.200.x	CA.040.200.x	CA.050.200.3			
224				CA.025.224.x	CA.032.224.x	CA.040.224.x	CA.050.224.3			
250				CA.025.250.x	CA.032.250.x	CA.040.250.x	CA.050.250.3	CA.063.250.3		
280					CA.032.280.x	CA.040.280.x	CA.050.280.x	CA.063.280.3		
315						CA.040.315.x	CA.050.315.x	CA.063.315.3	CA.080.315.3	
355							CA.050.355.x	CA.063.355.x	CA.080.355.3	
400							CA.050.400.x	CA.063.400.x	CA.080.400.3	CA.100.400.3
450								CA.063.450.x	CA.080.450.3	CA.100.450.3
500								CA.063.500.x	CA.080.500.3	CA.100.500.3
Ød	M5	M6	M8	M8	M8	M8	M10	M10	M12	M12

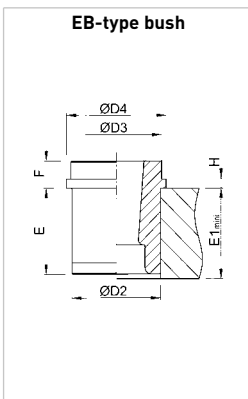

ØD1	12	16	20	25	32	40	50	63	80	100
E1 min.	REFERENCE									
25	23	EB.012.025.1								
32	30		EB.016.032.1							
40	38		EB.020.040.1	EB.025.040.2						
50	48			EB.025.050.1	EB.032.050.2	EB.040.050.3				
63	61				EB.032.063.1	EB.040.063.2	EB.050.063.3			
80	78						EB.050.080.2	EB.063.080.3		
100	98							EB.063.100.2	EB.080.100.3	
125	123									EB.100.125.3
F	10	10	12	12	15	15	18	20	20	20
ØD2	22	28	32	40	50	63	80	90	110	140
ØD3	-	-	-	-	-	-	-	100	125	160
ØD4	25	32	36	45	56	70	90	110	135	170
H	3	3	4	4	5	5	6	10	10	10

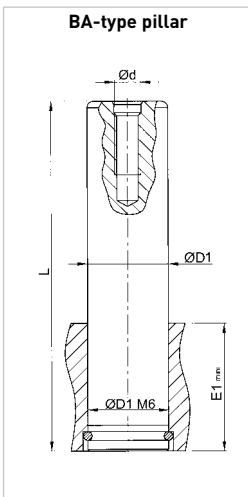

ØD1	12	16	20	25	32	40	50	63	80	100
L	REFERENCE									
100	BA.012.100	BA.016.100	BA.020.100							
110	BA.012.110	BA.016.110	BA.020.110	BA.025.110						
125	BA.012.125	BA.016.125	BA.020.125	BA.025.125	BA.032.125					
140	BA.012.140	BA.016.140	BA.020.140	BA.025.140	BA.032.140					
160	BA.012.160	BA.016.160	BA.020.160	BA.025.160	BA.032.160	BA.040.160				
180		BA.016.180	BA.020.180	BA.025.180	BA.032.180	BA.040.180				
200		BA.016.200	BA.020.200	BA.025.200	BA.032.200	BA.040.200	BA.050.200			
224				BA.025.224	BA.032.224	BA.040.224	BA.050.224			
250				BA.025.250	BA.032.250	BA.040.250	BA.050.250	BA.063.250		
280					BA.032.280	BA.040.280	BA.050.280	BA.063.280		
315					BA.032.315	BA.040.315	BA.050.315	BA.063.315	BA.080.315	
355						BA.040.355	BA.050.355	BA.063.355	BA.080.355	BA.100.355
400						BA.040.400	BA.050.400	BA.063.400	BA.080.400	BA.100.400
450							BA.050.450	BA.063.450	BA.080.450	BA.100.450
500							BA.050.500	BA.063.500	BA.080.500	BA.100.500
E1 min.	20	25	32	40	50	63	80	100	125	160
Ød	M5	M6	M8	M8	M8	M8	M10	M10	M12	M12

GUIDE BUSH

HB
JB
NB
GB



Compliant with AFNOR standards NF E 63.120/121/122/123/124/125.

TO DETERMINE THE CORRECT "GUIDABILLE"

- 1) Choose the type of pillar BA or CA/EB and the length according to the die height (DH).
- 2) Choose the type of bush HB or JB (avoid GB) and check that the stroke V corresponds to your needs.
- 3) When you have determined the type of bush HB or JB, check that your plate has the correct thickness to accommodate your bush and read off horizontally towards the right where you will automatically find the ball bearing cage PA.

Legend On request

ØD1	12	16	20	25	32	40	50	63	80	100
ØD2	22	28	32	40	50	63	80	90	110	140
ØD3	-	-	-	-	-	-	-	100	125	150
ØD4	25	32	36	45	56	70	90	110	135	160
H	3	3	4	4	5	5	6	10	10	10

EB-type bush

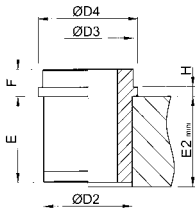

ØD1	12	16	20	25	32	40	50	63	80	100
E2 min.	E	REFERENCE								
25	23	HB.012.025	HB.016.025	HB.020.025						
32	30	HB.012.032	HB.016.032	HB.020.032	HB.025.032					
40	38	HB.012.040	HB.016.040	HB.020.040	HB.025.040	HB.032.040				
50	48		HB.016.050	HB.020.050	HB.025.050	HB.032.050	HB.040.050			
63	61			HB.020.063	HB.025.063	HB.032.063	HB.040.063	HB.050.063		
80	78			HB.025.080	HB.032.080	HB.040.080	HB.050.080			
100	98					HB.040.100	HB.050.100	HB.063.100		
125	123							HB.063.125	HB.080.125	
160	158								HB.080.160	HB.100.160
200	198									HB.100.200
F	10	10	12	12	15	15	18	20	20	20

JB-type bush

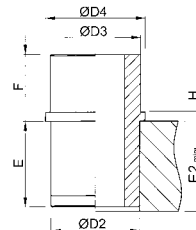

ØD1	12	16	20	25	32	40	50	60	80	100
E2 min.	E	REFERENCE								
25	23	JB.012.025	JB.016.025							
32	30	JB.012.032	JB.016.032	JB.020.032	JB.025.032	JB.032.032				
40	38		JB.016.040	JB.020.040	JB.025.040	JB.032.040	JB.040.040	JB.050.040		
50	48			JB.020.050	JB.025.050	JB.032.050	JB.040.050	JB.050.050		
63	61				JB.025.063	JB.032.063	JB.040.063	JB.050.063		
80	78						JB.040.080	JB.050.080		
100	98							JB.050.100	JB.063.100	
125	123								JB.063.125	JB.080.125
160	158								JB.080.160	JB.100.160
200	198									JB.100.200
F	25	32	36	40	45	50	63	63	70	80

NB-type bush

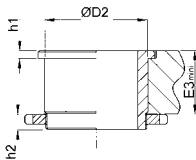

ØD1	12	16	20	25	32	40	50	63	80	100
E3 min.	REFERENCE									
12	NB.012.012	NB.016.012								
16		NB.016.016	NB.020.016							
20			NB.020.020	NB.025.020	NB.032.020					
25				NB.025.025	NB.032.025	NB.040.025				
32					NB.032.032	NB.040.032	NB.050.032			
40						NB.040.040	NB.050.040			
h1	2	3	3	3	4	4	5			
h2	4	4	5	6	6	7	9			

GB-type bush

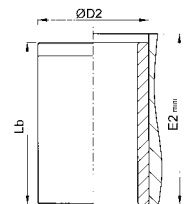

ØD1	12	16	20	25	32	40	50	63	80	100
E2 min.	Lp	REFERENCE								
32	30	GB.012.032	GB.016.032	GB.020.032						
40	38	GB.012.040	GB.016.040	GB.020.040	GB.025.040					
50	48	GB.012.050	GB.016.050	GB.020.050	GB.025.050	GB.032.050				
63	61			GB.020.063	GB.025.063	GB.032.063	GB.040.063			
80	78			GB.020.080	GB.025.080	GB.032.080	GB.040.080	GB.050.080		
100	98					GB.032.100	GB.040.100	GB.050.100		
125	123						GB.040.125	GB.050.125		
160	158							GB.050.160		



According to AFNOR standards
NF E 63.120/121/122/123/124/125.

For special applications, it is possible to mount ball bearing cages that are of different lengths to the guide bushes.

Legend On request

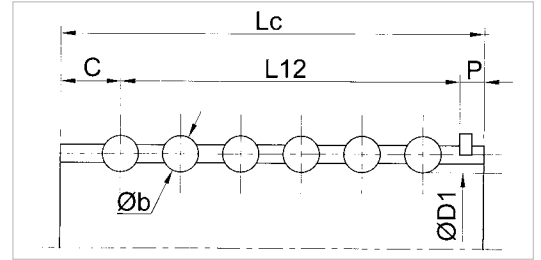

ØD1	12	16	20	25	32	40	50	63	80	100
Øb	2	2	2,5	3,5	4	5	6,5	6	6	7,5
P	2,6	2,8	2,8	3,6	3,9	3,9	4,2	5,2	6,2	8,2
C	3	3	3,3	3,9	4,6	5,3	6	6	7	7
Lc	See table on page opposite									

PA-type ball bearing cage

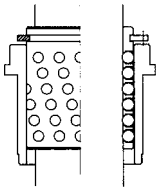

ØD1	12	16	20	25	32	40	50	63	80	100
Height HB	REFERENCE									
25	PA.012.11	PA.016.11	PA.020.10							
32	PA.012.13	PA.016.13	PA.020.12	PA.025.09						
40	PA.012.16	PA.016.16	PA.020.14	PA.025.11	PA.032.09					
50		PA.016.19	PA.020.17	PA.025.13	PA.032.11	PA.040.09				
63			PA.020.20	PA.025.15	PA.032.14	PA.040.11	PA.050.10			
80				PA.025.19	PA.032.17	PA.040.14	PA.050.12			
100						PA.040.16	PA.050.14	PA.063.14		
125								PA.063.17	PA.080.17	
160									PA.080.21	PA.100.18
200										PA.100.22

PA-type ball bearing cage

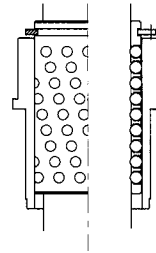

ØD1	12	16	20	25	32	40	50	63	80	100
Height JB	REFERENCE									
25	PA.012.16	PA.016.18								
32	PA.012.18	PA.016.20	PA.020.18	PA.025.15	PA.032.13					
40		PA.016.24	PA.020.20	PA.025.17	PA.032.15	PA.040.13	PA.050.12			
50			PA.020.23	PA.025.19	PA.032.17	PA.040.14	PA.050.14			
63				PA.025.21	PA.032.19	PA.040.16	PA.050.15			
80						PA.040.19	PA.050.17			
100							PA.050.19	PA.063.19		
125								PA.063.22	PA.080.23	
160									PA.080.27	PA.100.24
200										PA.100.28

PA-type ball bearing cage

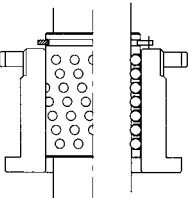

ØD1	12	16	20	25	32	40	50	63	80	100
Height NB	REFERENCE									
12	PA.012.05	PA.016.05								
16		PA.016.07	PA.020.06							
20			PA.020.07	PA.025.06	PA.032.05					
25				PA.025.07	PA.032.06	PA.040.05				
32					PA.032.07	PA.040.06	PA.050.05			
40						PA.040.07	PA.050.06			

PA-type ball bearing cage

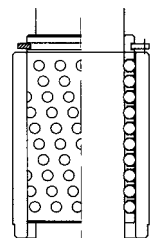

ØD1	12	16	20	25	32	40	50	63	80	100
Height GB	REFERENCE									
32	PA.012.10	PA.016.10	PA.020.08							
40	PA.012.13	PA.016.13	PA.020.11	PA.025.08						
50	PA.012.16	PA.016.16	PA.020.13	PA.025.10	PA.032.09					
63			PA.020.17	PA.025.13	PA.032.11	PA.040.09				
80			PA.020.22	PA.025.17	PA.032.14	PA.040.11	PA.050.10			
100					PA.032.17	PA.040.14	PA.050.12			
125						PA.040.18	PA.050.15			
160							PA.050.19			

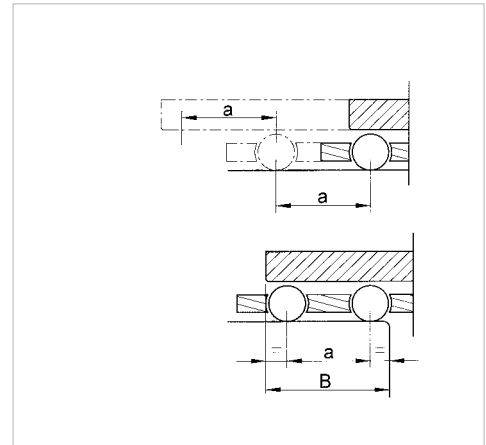
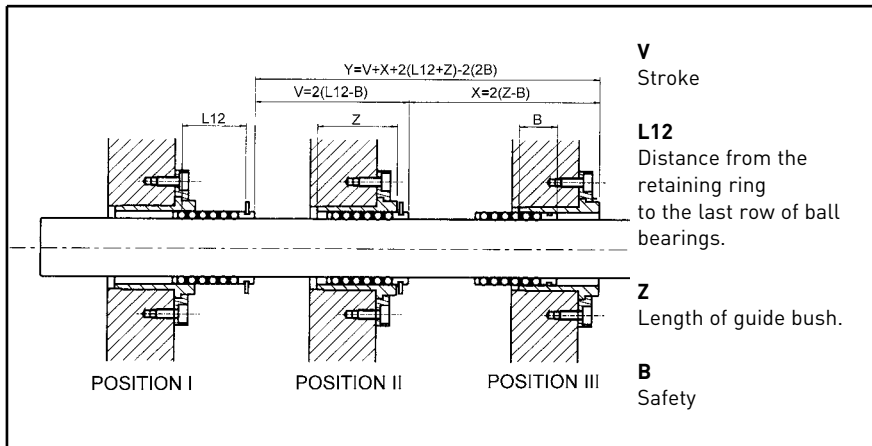

ØD1	12				16				20				25				32				40				50				63				80				100								
B	8				8				10				13				15				19				23				24				29				31								
Ht HB	L12	Z	V	Lc	L12	Z	V	Lc	L12	Z	V	Lc	L12	Z	V	Lc	L12	Z	V	Lc	L12	Z	V	Lc	L12	Z	V	Lc	L12	Z	V	Lc	L12	Z	V	Lc	L12	Z	V	Lc	L12	Z	V	Lc	
25	33	33	50	38,6	33	33	50	38,8	36,4	35	53	42,5																																	
32	39	40	62	44,6	39	40	62	44,8	43,6	42	67	49,7	42,6	42	59	50,1																													
40	48	48	80	53,6	48	48	80	53,8	50,8	50	82	56,9	52	50	78	59,5	50,8	53	72	59,3																									
50					57	58	98	62,8	61,6	60	103	67,7	61,4	60	97	68,9	62	63	94	70,5	61,4	63	85	70,6																					
63								72,4	73	125	78,5	70,8	73	116	78,3	78,8	76	127	87,3	75	76	112	84,2	82,7	79	119	92,9																		
80												89,6	90	153	97,1	95,6	93	161	104,1	95,4	93	153	104,6	99,3	96	153	109,5																		
100																				109	113	180	118,2	115,9	116	186	126,1	115,9	118	184	127,1														
125																											140,8	143	234	152	140,8	143	224	154											
160																														174	178	290	187,2	179	178	296	194,2								
200																																						219	218	376	234,2				

ØD1	12				16				20				25				32				40				50				63				80				100											
Ht JB	L12	Z	V	Lc	L12	Z	V	Lc	L12	Z	V	Lc	L12	Z	V	Lc	L12	Z	V	Lc	L12	Z	V	Lc	L12	Z	V	Lc	L12	Z	V	Lc	L12	Z	V	Lc	L12	Z	V	Lc	L12	Z	V	Lc	L12	Z	V	Lc
25	48	48	80	53,6	54	55	92	59,8																																								
32	54	55	92	59,6	60	62	104	65,8	65,2	66	110	71,3	70,8	70	116	78,3	73,1	75	116	81,6																												
40					72	70	128	77,8	72,4	74	125	78,5	80,2	78	134	87,7	84,4	83	139	92,9	88,6	88	139	97,8	99,3	101	153	109,5																				
50								83,2	84	146	89,3	89,6	88	153	97,1	95,6	93	161	104,1	95,4	98	153	104,6	115,9	111	186	126,1																					
63													99	101	172	106,5	106,8	106	184	115,3	109	111	180	118,2	124,2	124	202	134,4																				
80																				129,4	128	221	138,6	140,8	141	236	151																					
100																											157,4	161	269	167,6	157,4	161	267	168,6														
125																													182,3	186	317	193,5	190,6	193	323	203,8												
160																															223,8	228	390	237	239	238	416	254,2										
200																																							279	278	496	294,2						

ØD1	12				16				20				25				32				40				50				63				80				100											
Ht NB	L12	Z	V	Lc	L12	Z	V	Lc	L12	Z	V	Lc	L12	Z	V	Lc	L12	Z	V	Lc	L12	Z	V	Lc	L12	Z	V	Lc	L12	Z	V	Lc	L12	Z	V	Lc	L12	Z	V	Lc	L12	Z	V	Lc	L12	Z	V	Lc
12	15	16	14	20,6	15	16	14	20,8																																								
16					21	20	26	26,8	22	21	24	28,1																																				
20									25,6	25	31	31,7	28,5	26	31	36	28,4	26	27	36,9																												
25												33,2	31	40	40,7	34	31	38	42,5	34,2	32	30	43,4																									
32																39,6	38	49	48,1	41	39	44	50,2	41,2	41	36	51,4																					
40																				47,8	47	58	57	49,5	49	52	59,7																					

ØD1	12				16				20				25				32				40				50				63				80				100											
Ht GB	L12	Z	V	Lc	L12	Z	V	Lc	L12	Z	V	Lc	L12	Z	V	Lc	L12	Z	V	Lc	L12	Z	V	Lc	L12	Z	V	Lc	L12	Z	V	Lc	L12	Z	V	Lc	L12	Z	V	Lc	L12	Z	V	Lc	L12	Z	V	Lc
32	30	30	44	35,6	30	30	44	35,8	29,2	30	38	35,3																																				
40	39	38	62	44,6	39	38	62	44,8	40	38	60	46,1	37,9	38	50	45,4																																
50	48	48	80	53,6	48	48	80	53,8	47,2	48	74	53,3	47,3	48	69	54,8	50,8	48	72	59,3																												
63								61,6	61	103	67,7	61,4	61	97	68,9	62	61	94	70,5	61,4	61	85	70,6																									
80								79,6	78	139	85,7	80,2	78	134	87,7	78,8	78	128	87,3	75	78	112	84,2	82,7	78	119	92,9																					
100																95,6	98	161	104,1	95,4	98	153	104,6	99,3	98	153	109,5																					
125																																																
160																																																

For $\varnothing D1 \leq 25$

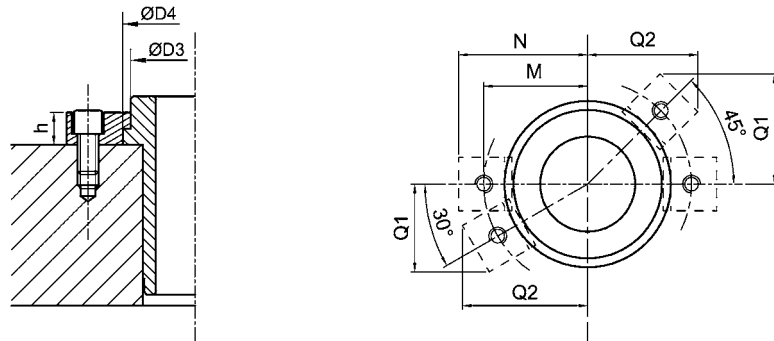

For $32 \leq \varnothing D1 \leq 50$

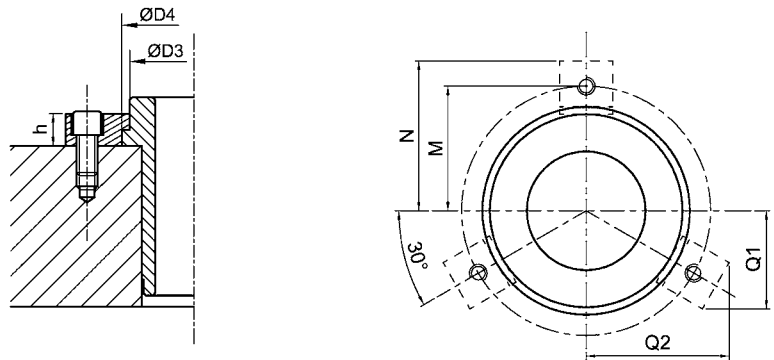

For $\varnothing D1 \leq 63$

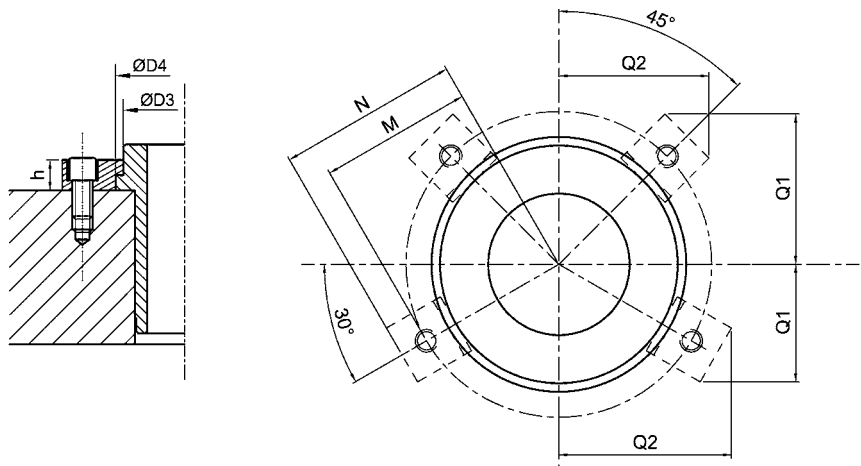

$\varnothing D1$	12	16	20	25	32	40	50	63	80	100		
$\varnothing D3$	22	29	32	41	51	65	84	100	125	150	160	
$\varnothing D4$	25	32	36	45	56	70	90	110	135	160	170	
M	17	20,5	23	27,5	35	42	54	65	77,5	90	95	
N	23	26,5	30	34,5	43,5	50,5	64	76	88,5	101	106	
T	5	5	7	7	9	9	11	18	18	18	18	
at 30°	Q1	16,7	18,4	21,1	23,3	29,5	33	41,5	49,3	55,5	61,8	64,3
	Q2	22,9	25,9	29,5	33,4	42,2	48,2	60,9	72,3	83,1	94	98,3
at 45°	Q1 = Q2	20,5	23	26,2	29,3	37,1	42,1	53	62,9	71,8	80,6	84,1
Clamp	B03.004.000		B03.005.000		B03.006.000		B03.008.000	B03.010.000				
Screw	M4 x 12		M5 x 12		M6 x 12		M8 x 16	M10 x 25				
Quantity	2		2		3		3	4				

DEMOUNTABLE PILLAR WITH RETAINING COLLAR

EPO



Core-hardened
to 60 - 64 HRc

Ordering example:

Pillar D1=32 L=180

Please state:
EPO.032.180

To be used with



Type 3 ball bearing cage
Type PA

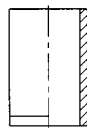

Straight sleeve bush for
ball bearing cage
Type GB

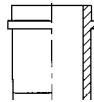

Short demountable bush for
ball bearing cage
Type NB or HB

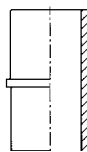

Demountable bush for ball
bearing cage
Type JB

Examples

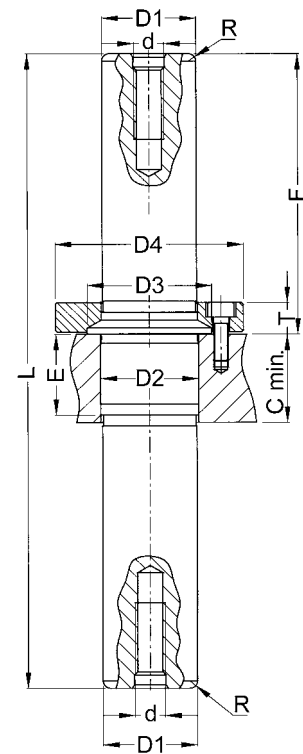
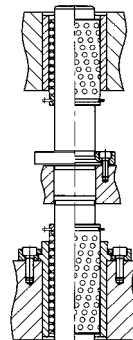
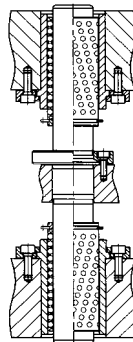
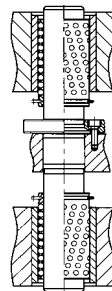

Supplied with

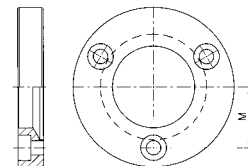

D1		20	25	32	40
L	F	REFERENCES			
160	70	EPO.020.160		EPO.032.180	
180	80	EPO.020.180	EPO.025.180	EPO.032.180	
200	90	EPO.020.200	EPO.025.200	EPO.032.200	EPO.040.200
220	100		EPO.025.220	EPO.032.220	EPO.040.220
240	110			EPO.032.240	
250					EPO.040.250
D2		22	26	32,5	42
D3		27	33	40	49
D4		44	50	62	71
E		20	22	25	27
d		M8			
R		1,5	2,0		2,5
M		16	19	24	28
C mini.		22	24	27	29
T		9		10	11
Clamp		P04.020.000	P04.025.000	P04.032.000	P04.040.000
Screw		A05.004.012 (M4x12)		A05.005.012 (M5x12)	A05.006.012 (M6x12)
Quantity		3			



Ordering example
Pillar D1=25 L=220

Please state :
CMF.025.220

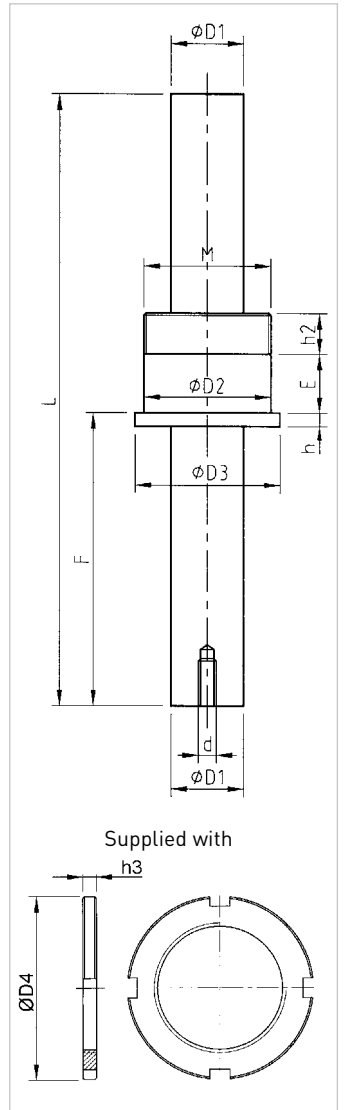
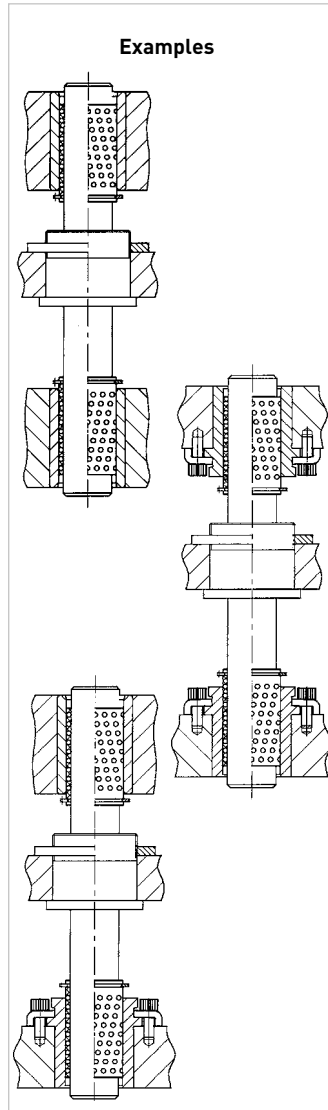
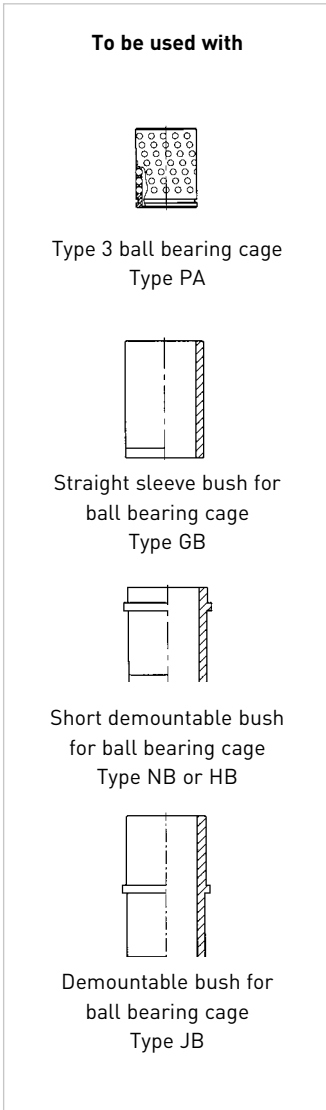

D1			16	20	25	32	40
L	F	E	REFERENCES				
135	65	13	CMF.016.135	CMF.020.135			
200	90	17		CMF.020.200			
165	74	22			CMF.025.165		
215	110	22			CMF.025.215		
220		27			CMF.025.220	CMF.032.220	CMF.040.220
240	112	35				CMF.032.240	CMF.040.240
D2			28	32	40	50	63
D3			32	36	45	56	70
d			M5	M6	M8		
h			3		4		
h2			9		11		
Nut			B04.016.000	B04.020.000	B04.025.000	B04.032.000	B04.040.000
M			27x100	30x100	39x100	48x100	60x100
h3			3	4		5	6
D4			40	44	55	65	81

RETAINING STOP

BAD



The retaining stop prevents the release of the ball bearing cage if the pillars pull out completely.

The retainer can operate at a variable height H, for which the standards are set out in the table below.

Height H is obtained by stacking the required number of spacers. Other heights can be obtained upon request.

Ordering example

Pillar D1=16 mm; height H=16 mm
Please state : **BAD.016.016**

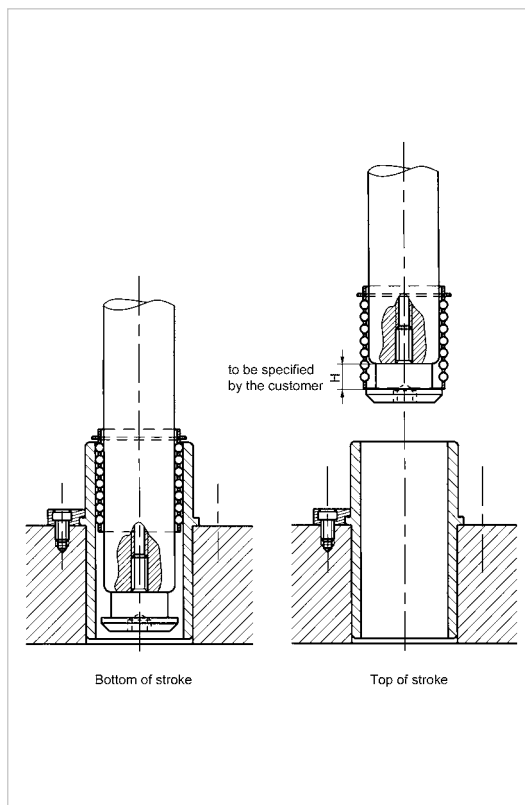

D1	12	16	20	25	32	40	50	63	80
Spacer height	8	8	10	10	10	10	15	15	20
H	REFERENCE								
8	BAD.012.008	BAD.016.008							
10			BAD.020.010	BAD.025.010	BAD.032.010	BAD.040.010			
15							BAD.050.015	BAD.063.015	BAD.080.015
16	BAD.012.016	BAD.016.016							
20			BAD.020.020	BAD.025.020	BAD.032.020	BAD.040.020			
24	BAD.012.024	BAD.016.024							
30			BAD.020.030	BAD.025.030	BAD.032.030	BAD.040.030	BAD.050.030		
32	BAD.012.032	BAD.016.032							
40			BAD.020.040	BAD.025.040	BAD.032.040	BAD.040.040			
45							BAD.050.045		
60							BAD.050.060		

RECOMMENDED ASSEMBLY TOLERANCES

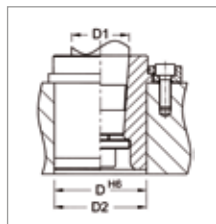

BUSH FOR TAPERED PILLAR, type EB										
D1	12	16	20	25	32	40	50	63	80	100
D2	22	28	32	40	50	63	80	90	110	140
D H₆	<u>22.000</u> 22.013	<u>28.000</u> 28.013	<u>32.000</u> 32.016	<u>40.000</u> 40.016	<u>50.000</u> 50.016	<u>63.000</u> 63.019	<u>80.000</u> 80.019	<u>90.000</u> 90.022	<u>110.000</u> 110.022	<u>140.000</u> 140.025

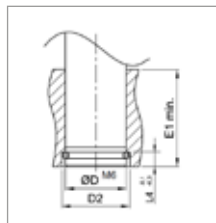

PILLAR WITH LOWER RETAINER, type BA										
D1	12	16	20	25	32	40	50	63	80	100
D2	14	18	23	28	37	45	55	70	87	107
L4	4	4	6	6	10	10	10	16	16	16
D H₆	<u>11.985</u> 11.996	<u>15.985</u> 15.996	<u>19.983</u> 19.996	<u>24.983</u> 24.996	<u>31.980</u> 31.996	<u>39.980</u> 39.996	<u>49.980</u> 49.996	<u>62.976</u> 62.995	<u>79.976</u> 79.995	<u>99.972</u> 99.994

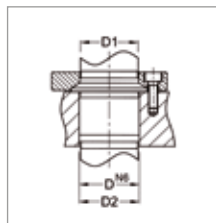

DEMOUNTABLE PILLAR WITH COLLAR, type EPO										
D1	20		25		32		40			
D2	22		26		34		42			
D H₆	<u>21.976</u> 21.989		<u>25.976</u> 25.989		<u>33.972</u> 33.988		<u>41.972</u> 41.988			

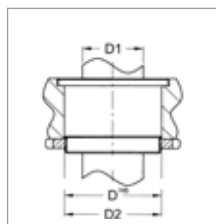

THREADED MIDDLE PILLAR, type CMF										
D1	16		20		25		32		40	
D2	28		32		40		50		63	
D H₆	<u>28.000</u> 28.013		<u>32.000</u> 32.016		<u>40.000</u> 40.016		<u>50.000</u> 50.016		<u>63.000</u> 63.019	

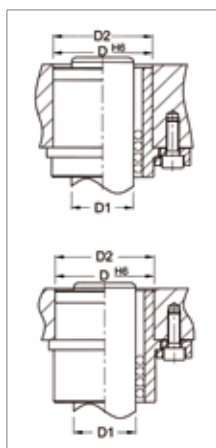

SHORT DEMOUNTABLE BUSH, type HB / DEMOUNTABLE BUSH, type JB										
D1	12	16	20	25	32	40	50	63	80	100
D2	22	28	32	40	50	63	80	90	110	140
D H₆	<u>22.000</u> 22.013	<u>28.000</u> 28.013	<u>32.000</u> 32.016	<u>40.000</u> 40.016	<u>50.000</u> 50.016	<u>63.000</u> 63.019	<u>80.000</u> 80.019	<u>90.000</u> 90.022	<u>110.000</u> 110.022	<u>140.000</u> 140.025

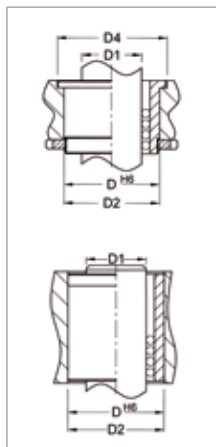

INTERMEDIATE BUSH, type NB / SMOOTH BUSH, type GB										
D1	12	16	20	25	32	40	50			
D2	22	28	32	40	50	63	80			
D3 (bush NB)	26	33	37	46	57	71	91			
D H₆	<u>22.000</u> 22.013	<u>28.000</u> 28.013	<u>32.000</u> 32.016	<u>40.000</u> 40.016	<u>50.000</u> 50.016	<u>63.000</u> 63.019	<u>80.000</u> 80.019			

1/2 snap ring for cylindrical pillar with lower retainer.

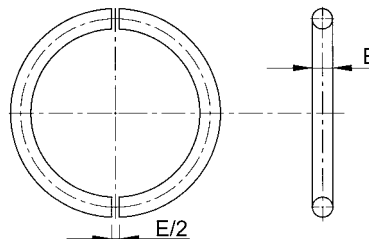
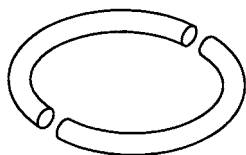

Ø Pillar	12	16	20	25	32
REFERENCE	P01.012.000	P01.016.000	P01.020.000	P01.025.000	P01.032.000
E	1,6		2,5		4,0
Ø Pillar	40	50	63	80	100
REFERENCE	P01.040.000	P01.050.000	P01.063.000	P01.080.000	P01.100.000
E	4,0		6,0		

Retaining washer for pillar with tapered fitting.

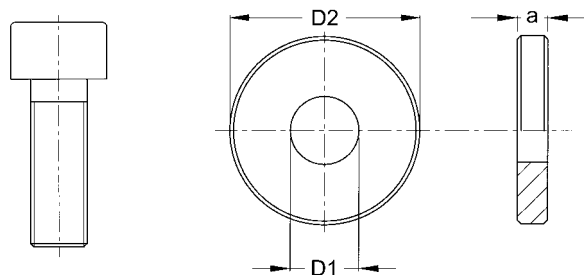
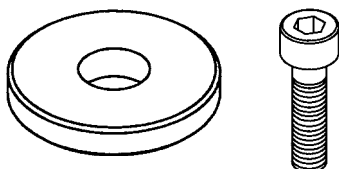

Ø Pillar	12	16	20	25	32
REFERENCE	P03.012.000	P03.016.000	P03.020.000	P03.025.000	P03.032.000
D1	5,5	6,6		9,0	
D2	14	18	22	25	32
a	2	3		4	
Screw	A05.005.012 (M5x12)	A05.006.012 (M6x12)		A05.008.016 (M8x16)	
Ø Pillar	40	50	63	80	100
REFERENCE	P03.040.000	P03.050.000	P03.063.000	P03.080.000	P03.100.000
D1	9	11	14	18	
D2	40	50	63	80	100
a	4	5	6	8	10
Screw	A05.008.016 (M8x16)	A05.010.020 (M10x20)	A05.012.020 (M12x20)	A05.016.035 (M16x35)	

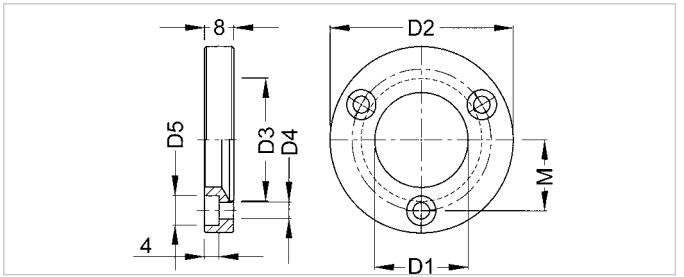
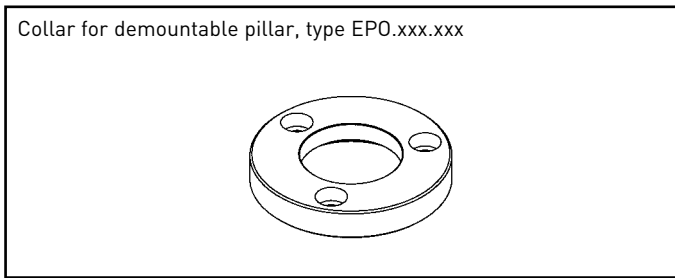

Ø Pillar	20	25	32	40
REFERENCE	P04.020.000	P04.025.000	P04.032.000	P04.040.000
D1	22	26	33	41
D2	44	50	62	71
D3	27	33	40	49
D4	4,5		5,5	6,6
D5	7,5		9	10,5
M	32	38	48	56
Clamp	A05.004.012 (M4x12)		A05.005.012 (M5x12)	A05.006.012 (M6x12)

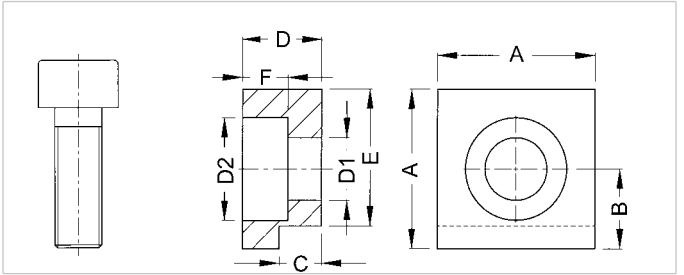
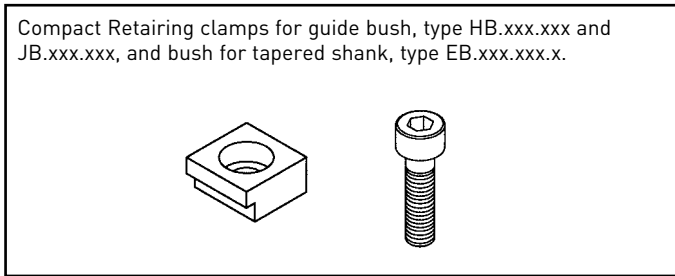

REFERENCE	B03.004.000	B03.005.000	B03.006.000	B03.008.000	B03.010.000
D1	4,5	5,5	6,6	9,0	11,0
D2	8	9	12	16	18
A	12	14	18	22	26
B	6,0	7,0	9,5	12,0	15,0
C	2,75	3,75	4,75	5,75	9,75
D	5	7	9	11	18
E	10,5	12,0	15,5	19,0	21,0
F	3	4	5	7	10
Screw	A05.004.012 (M4x12)	A05.005.012 (M5x12)	A05.006.012 (M6x12)	A05.008.016 (M8x16)	A05.010.025 (M10x25)

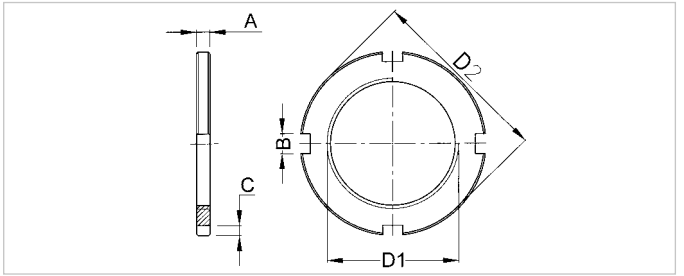
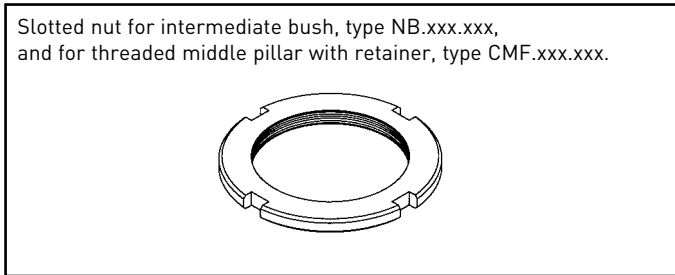

Ø Pillar	12	16	20	25	32	40	50
REFERENCE	B04.012.000	B04.016.000	B04.020.000	B04.025.000	B04.032.000	B04.040.000	B04.050.000
D1	M22x1	M27x1	M30x1	M39x1	M48x1	M60x1	M76x1
D2	34	40	44	55	65	81	100
A	3		4		5	6	8
B	4	5		6		7	
C	2,5	3,0		3,5			4,0

GUIDE PILLAR

1/2 SNAP-RING LOWER CLAMPING

RI

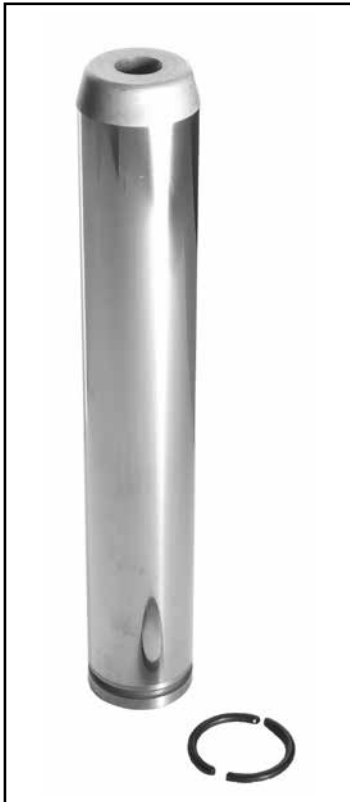

Manufactured according to **NF E 63-050**.

Material :

- 16 NC 6 Face-hardened steel
- Rockwell HRc > 60

Tolerances :

For the bed-Plate we do recommend M6 boring out.

Nota :

- MABEC code for some items.
- Other dimensions available upon request.

Example

Type = RI, D1 = 32mm, L = 180mm
Please state : **RI.032.180**

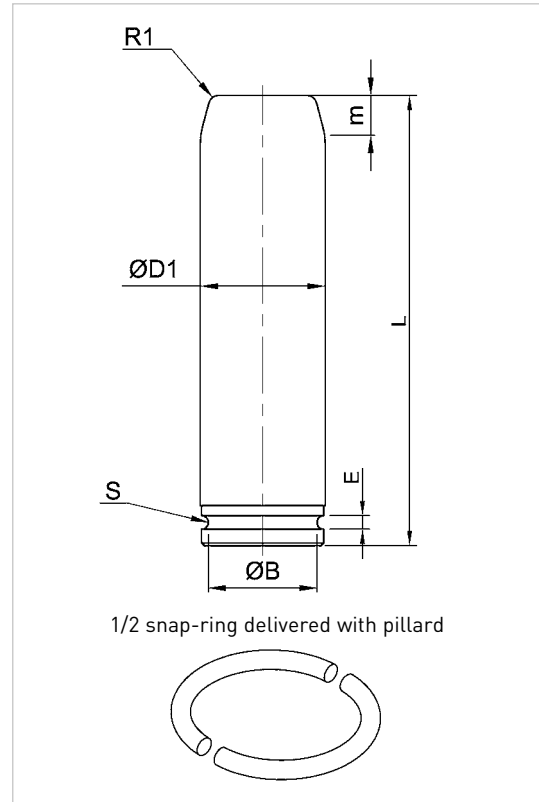
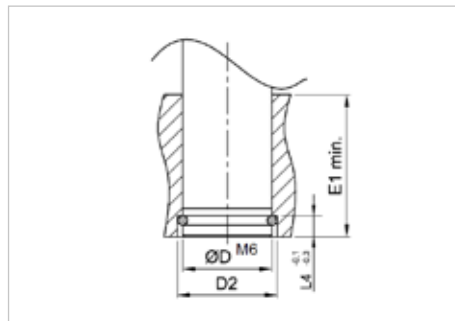

D1	12	16	20	25	32	40	50	63	80	100
L	REFERENCES									
80	RI.012.080									
100	RI.012.100	RI.016.100	RI.020.100	RI.025.100						
125	RI.012.125	RI.016.140	RI.020.125	RI.025.125	RI.032.125					
140		RI.016.160	RI.020.140	RI.025.140	RI.032.140					
160		RI.016.180	RI.020.160	RI.025.160	RI.032.160	RI.040.160				
180			RI.020.180	RI.025.180	RI.032.180	RI.040.180				
200			RI.020.200	RI.025.200	RI.032.200	RI.040.200	RI.050.200			
224				RI.025.224	RI.032.224	RI.040.224	RI.050.224			
250					RI.032.250	RI.040.250	RI.050.250	RI.063.250		
280						RI.040.280	RI.050.280	RI.063.280		
315							RI.050.315	RI.063.315	RI.080.315	
355									RI.080.355	
400							RI.050.400*		RI.080.400	
450										RI.100.450
B	10,3	14,3	17,3	22,3	27,8	35,8	45,8	56,8	73,8	93,8
m	4	5	6	8	10	12	16	16	16	16
E	1,7	1,7	2,7	2,7	4,2	4,2	4,2	6,5	6,2	6,2
R1	2	2	2	2	2	3	3	5	5	5
S	0,85	0,85	1,35	1,35	2,1	2,1	2,1	3,1	3,1	3,1
E1 min	20	25	32	40	50	63	80	100	125	160
L4	4	4	6	6	10	10	10	16	16	16
D	12	16	20	25	32	40	50	63	80	100
D2	14	18	23	28	37	45	55	74	87	107
Ref. 1/2 snap-rings	P01.012.000	P01.016.000	P01.020.000	P01.025.000	P01.032.000	P01.040.000	P01.050.000	P01.063.000	P01.080.000	P01.100.000

GUIDE PILLAR

1/2 SNAP-RING MEDIUM CLAMPING

RM



Manufactured according to **NF E 63-050**.

- Material :**
- 16 NC 6 Face-hardened steel
 - Rockwell HRc > 60

Tolerances :
Dimensions without tolerance indication = +/- 0.5. For the bed-plate, we do recommend an H6 boring out.

- Nota :**
- MABEC code for some items

Ordering example

Type = RM, D1 = 50mm, L = 224mm
Please state : **RM.050.224**

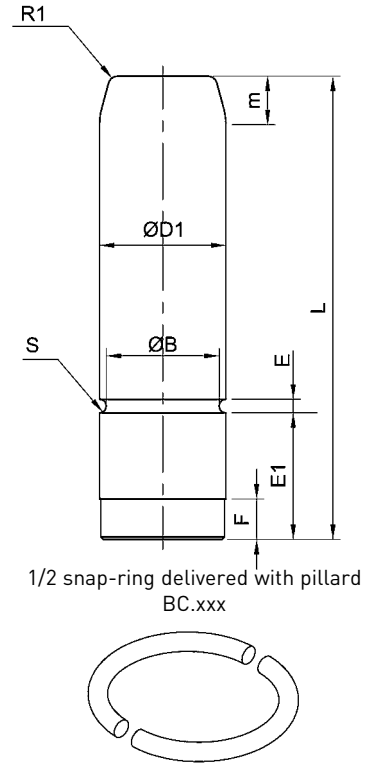
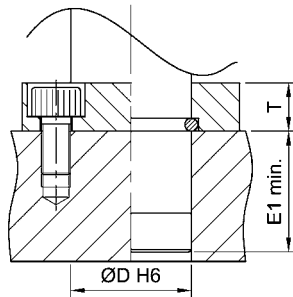

D1	25	32	40	50	63	80	100
L	REFERENCES						
100	RM.025.100						
125	RM.025.125	RM.032.125					
140	RM.025.140	RM.032.140					
160	RM.025.160	RM.032.160	RM.040.160				
180	RM.025.180	RM.032.180	RM.040.180				
200	RM.025.200	RM.032.200	RM.040.200	RM.050.200			
224	RM.025.224	RM.032.224	RM.040.224	RM.050.224			
250		RM.032.250	RM.040.250	RM.050.250	RM.063.250		
280				RM.050.280	RM.063.280		
315				RM.050.315	RM.063.315	RM.080.315	
355				RM.050.355	RM.063.355	RM.080.355	RM.100.355
400				RM.050.400		RM.080.400	RM.100.400
450							RM.100.450
B	22,3	27,8	35,8	45,8	56,8	73,8	93,8
m	8	10	12	16	16	16	16
E1	25	32	63	80	100	125	160
E	2,7	4,2	4,2	4,2	6,2	6,2	6,2
F	8	12	12	12	18	18	18
R1	2	2	3	3	5	5	5
S	1,35	2,1	2,1	2,1	3,1	3,1	3,1
T	10	10	12	14	18	20	20
E1 min	25	32	63	80	100	125	160
D	25	32	40	50	63	80	100
Ref. 1/2 snap-rings	P01.025.000	P01.032.000	P01.040.000	P01.050.000	P01.063.000	P01.080.000	P01.100.000

DISASSEMBLING GUIDE PILLARS WITH PIXING CLAMPS

RID



Manufactured according to **NF E 63-050**.

Material : Steel

- Rockwell HRC > 60 hardness
- R > 1070 N/mm² resistance to substratum traction

Tolerances :

Dimensions without tolerance indication = +/- 0.5

Nota :

- Pillars can be used with our aluanodised bushings, steel or bronze, as well as in semi-blocks.

Ordering example

Type = RID, D1 = 32mm, L=180mm
Please state : **RID.032.180**

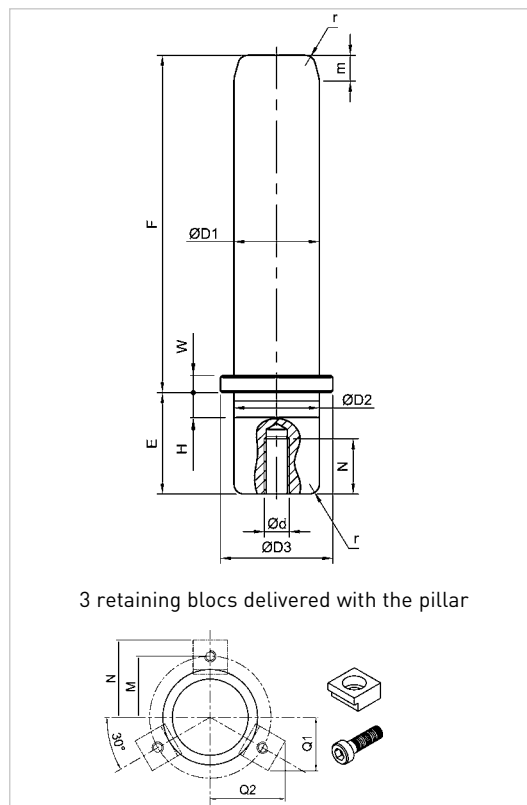
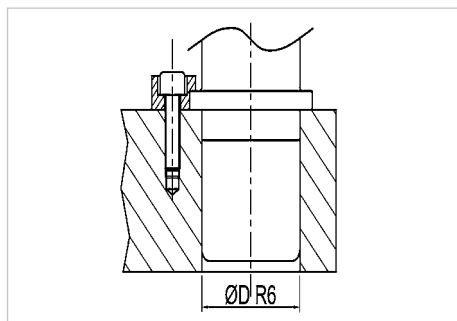

D1	20	25	32	40	50	63
F	REFERENCES					
80	RID.020.080	RID.025.080				
100	RID.020.100	RID.025.100	RID.032.100			
112	RID.020.112	RID.025.112	RID.032.112	RID.040.112		
125	RID.020.125	RID.025.125	RID.032.125	RID.040.125	RID.050.125	
140	RID.020.140	RID.025.140	RID.032.140	RID.040.140	RID.050.140	RID.063.140
160	RID.020.160	RID.025.160	RID.032.160	RID.040.160	RID.050.160	RID.063.160
180		RID.025.180	RID.032.180	RID.040.180	RID.050.180	RID.063.180
200			RID.032.200	RID.040.200	RID.050.200	RID.063.200
224			RID.032.224	RID.040.224	RID.050.224	RID.063.224
250			RID.032.250	RID.040.250	RID.050.250	RID.063.250
280			RID.032.280	RID.040.280	RID.050.280	RID.063.280
315				RID.040.315	RID.050.315	RID.063.315
355					RID.050.355	RID.063.355
400						RID.063.400
D2 = E	20	25	32	40	50	63
D3	26	32	40	50	63	76
m	6	8	10	12	16	16
W	4	4	5	5	6	10
H	4	5	6	8	10	12
ØdxN	M8 x 20	M8 x 20	M8 x 20	M8 x 20	M10 x 25	M10 x 25
Clamps	B03.005.000	B03.005.000	B03.006.000	B03.006.000	B03.008.000	B03.010.000
Screw	A05.005.012	A05.005.012	A05.006.016	A05.006.016	A05.008.020	A05.010.025
M/N	18/25	21/28	27/35,5	32/40,5	40,5/50,5	48/59
Q1/Q2	18,6/25,2	20,1/27,7	25,5/35,2	28/39,6	34,8/49,2	40,8/57,6

BRONZE GUIDE BUSCH WITH COLLAR

BRO



«Bronze» guide bush characteristics

- Interior spider legs
- Finely ground
- Assembled on bed-plate with retaining blocks and screws
- Bushings interchangeability
- Hardness : > 170 HB
- Bed-plate boring out tolerance : H7
- Built-in lubricator

Ordering example

Type = BRO, D1 = 32mm, L=46mm
Please state : **BRO.032.046**

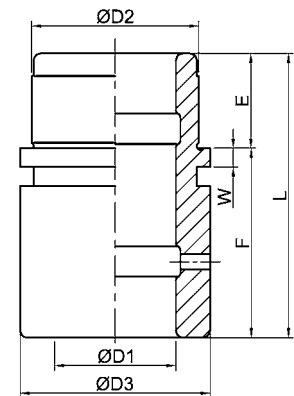
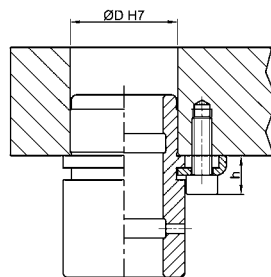

Delivered with clamps and screws

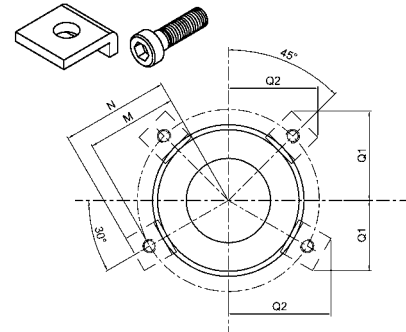

D1			20	25	32	40	50	63	80
L	F	E	REFERENCES						
34	16	18	BRO.020.034						
50	32		BRO.020.050						
43	21	22		BRO.025.043					
66	44		BRO.025.066						
46	21	25			BRO.032.046				
75	50		BRO.032.075						
56	21	35				BRO.040.056			
85	50		BRO.040.085						
70	25	45					BRO.050.070		
95	50		BRO.050.095						
70	25	45						BRO.063.070	BRO.080.070
108	63		BRO.063.108						BRO.080.108
D2			28	35	44	52	63	80	100
D3			32	43	50	59	75	91	110
W			4	4	5	5	5	5	5
Clamps			B03.006.100	B03.006.100	B03.008.100	B03.008.100	B03.008.100	B03.008.100	B03.008.100
Clamps qty			2	2	3	3	4	4	4
Screws			A05.006.016	A05.006.016	A05.008.020	A05.008.020	A05.008.020	A05.008.020	A05.008.020
h			12	12	15,5	15,5	15,5	15,5	15,5
M			21,5	27	32	36,5	44,5	52,5	64
N			28	33,5	42	46,5	54,5	62,5	72
Clamps at 30°		Q1	21,2	23,9	28,8	31	35	39	43,9
		Q2	28,7	33,4	40,9	44,8	51,7	58,6	66,9
Clamps at 45°		Q1 = Q2	25,8	29,7	36,1	39,2	44,9	50,6	57,3

«ALUANODISED» GUIDE BUSH WITH COLLAR

ALU



“ALUANODISED” Guide Bush Characteristics

- Great resistance to wear and tear
- Self-lubricating (lubricating when fitting is enough : use light oil)
- Non corrosive
- Non magnetic
- Assembled on bed-plate with clamps and screws
- Bushing interchangeable
- Hardness : 70/71 Hrc
- Bed-plate boring out tolerance : H7

Example

Type = ALU, D1 = 40mm, L=85mm
Please state : **ALU.040.085**

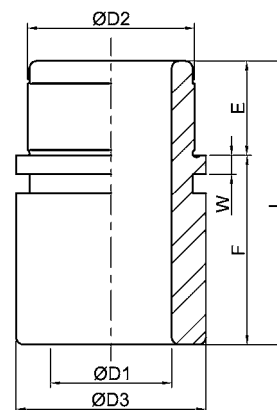
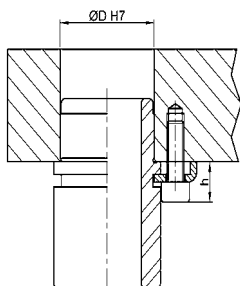

Delivered with clamps and screws

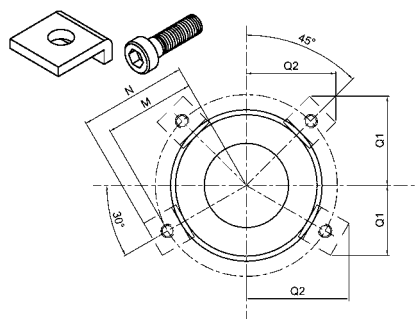

D1			20	25	32	40	50	63	80
L	F	E	REFERENCES						
34	16	18	ALU.020.034						
50	32		ALU.020.050						
43	21	22		ALU.025.043					
66	44		BALU.025.066						
46	21	25			ALU.032.046				
75	50		ALU.032.075						
56	21	35				ALU.040.056			
85	50		ALU.040.085						
70	25	45					ALU.050.070		
95	50		ALU.050.095						
70	25	45						ALU.063.070	ALU.080.070
108	63							ALU.063.108	ALU.080.108
D2			28	35	44	52	63	80	100
D3			32	43	50	59	75	91	110
W			4	4	5	5	5	5	5
Clamp			B03.006.100	B03.006.100	B03.008.100	B03.008.100	B03.008.100	B03.008.100	B03.008.100
Clamp qty			2	2	3	3	4	4	4
Screw			A05.006.016	A05.006.016	A05.008.020	A05.008.020	A05.008.020	A05.008.020	A05.008.020
h			12	12	15,5	15,5	15,5	15,5	15,5
M			21,5	27	32	36,5	44,5	52,5	64
N			28	33,5	42	46,5	54,5	62,5	72
Clamps at 30°		Q1	21,2	23,9	28,8	31	35	39	43,9
		Q2	28,7	33,4	40,9	44,8	51,7	58,6	66,9
Clamps at 45°		Q1 = Q2	25,8	29,7	36,1	39,2	44,9	50,6	57,3



Steel Guide Bush with collar

- Interior spider legs
- Finely ground
- Assembled on bed-plate with retaining blocks and screws
- Collars interchangeability
- Hardness : 61/63 Hrc on the surface
- Bed-plate boring out tolerance : H7
- Built-in lubricator

Example

Type = ACI, D1 = 50mm, L=70mm
Please state : **ACI.050.070**

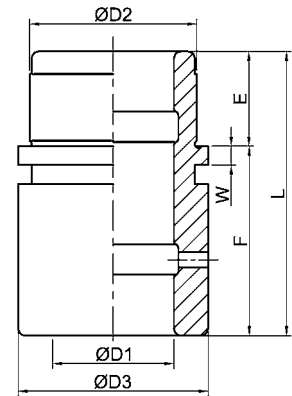
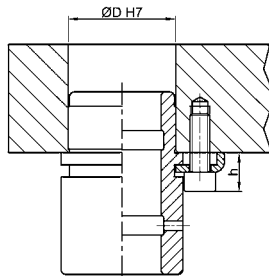

Delivered with clamps and screws

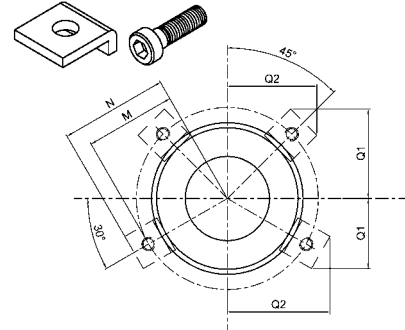

D1			20	25	32	40	50	63	80
L	F	E	REFERENCES						
34	16	18	ACI.020.034						
50	32		ACI.020.050						
43	21	22		ACI.025.043					
66	44		ACI.025.066						
46	21	25			ACI.032.046				
75	50		ACI.032.075						
56	21	35				ACI.040.056			
85	50		ACI.040.085						
70	25	45					ACI.050.070		
95	50		ACI.050.095						
70	25	45						ACI.063.070	ACI.080.070
108	63							ACI.063.108	ACI.080.108
D2			28	35	44	52	63	80	100
D3			32	43	50	59	75	91	110
W			4	4	5	5	5	5	5
Clamp			B03.006.100	B03.006.100	B03.008.100	B03.008.100	B03.008.100	B03.008.100	B03.008.100
Clamp qty			2	2	3	3	4	4	4
Screw			A05.006.016	A05.006.016	A05.008.020	A05.008.020	A05.008.020	A05.008.020	A05.008.020
h			12	12	15,5	15,5	15,5	15,5	15,5
M			21,5	27	32	36,5	44,5	52,5	64
N			28	33,5	42	46,5	54,5	62,5	72
Clamps at 30°		Q1	21,2	23,9	28,8	31	35	39	43,9
		Q2	28,7	33,4	40,9	44,8	51,7	58,6	66,9
Clamps at 45°		Q1 = Q2	25,8	29,7	36,1	39,2	44,9	50,6	57,3



Manufactured according to **AFNOR E 63-054**

Material :

- Bronze

Boring out tolerance :

For bed plate we do recommend H7 boring out

Nota :

- MABEC code for some items.
- Clamping elements should be ordered separately in our AFNOR catalog

Example

Type = BCA, D1 = 50mm, L=80mm
Please state : **BCA.050.080**

Hole punched after hafting

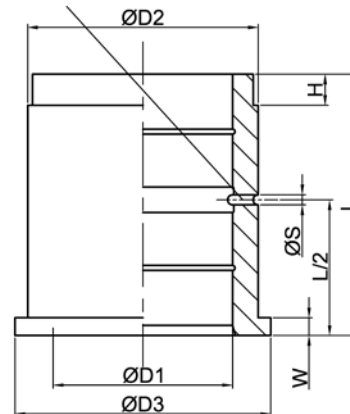

To be mounted with BDR.xxx, BRCB.xxx or B05.xxx.xxx below
(delivered separately)

D1	12	16	20	25	32	40	50	63	80	100
REF.	BCA.012.020	BCA.016.025	BCA.020.032	BCA.025.040	BCA.032.050	BCA.040.063	BCA.050.080	BCA.063.100	BCA.080.125	BCA.100.160
D2	18	22	28	35	44	52	63	80	100	125
D3	22	25	32	40	50	60	71	90	112	140
W	2,5	3	4	5	6	8	10	12	16	20
H	2	2,5	3	5	8	8	8	10	10	10
L	20	25	32	40	50	63	80	100	125	160
ØS	4	4	4	4	4	7	7	7	7	7

1/2 round retaining clamp
Reference BDR.xxx

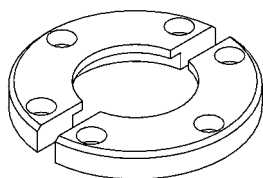

Square retaining clamp
Reference BRCB.xxx

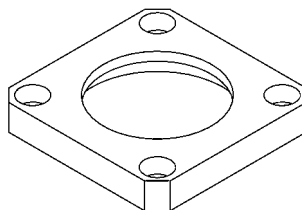

Compact retaining clamp
Reference B05.xxx.xxx

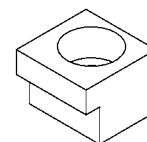



Material :
Bronze with impregnated friction graphite inserts

Boring out tolerance :
For bed plate we do recommend H7 boring out

Nota :

- MABEC code for some items.
- Clamping elements should be ordered separately in our AFNOR catalog

Example

Type = BBEI, D1 = 50mm
Please state : **BBEI.050**

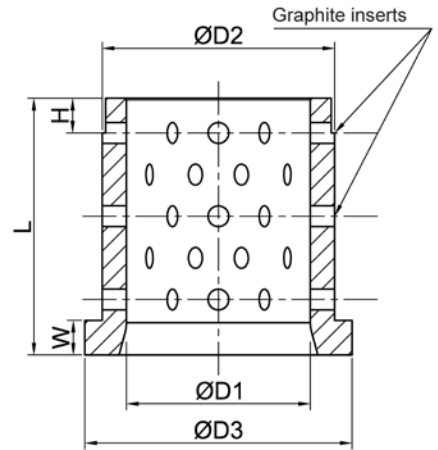

To be mounted with
BDR.xxx, BRCB.xxx or
B05.xxx.xxx below
(delivered separately)

D1 ^{Ø7}	20	25	32	40	50	63	80	100
RÉFÉRENCES	BBEI.020	BBEI.025	BBEI.032	BBEI.040	BBEI.050	BBEI.063	BBEI.080	BBEI.100
L	32	40	50	63	80	100	125	160
D2	28	35	44	52	63	80	100	125
D3	32	40	50	60	71	90	112	140
W	4	5	6	8	10	12	16	20

1/2 round retaining clamp
Reference BDR.xxx

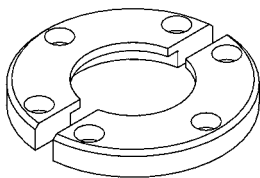

Square retaining clamp
Reference BRCB.xxx

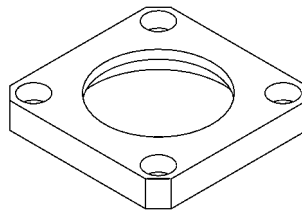

Compact retaining clamp
Reference B05.xxx.xxx

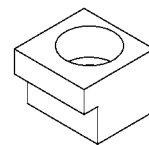

ACCESSORIES

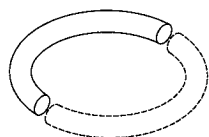

1/2 snap-ring for cylindrical pillar type RI and RM

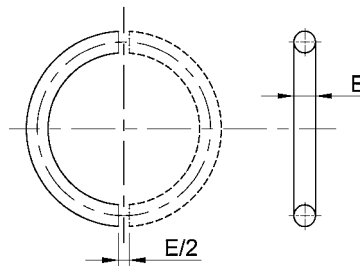

∅ Pillar	12	16	20	25	32
REFERENCES 1/2 SNAP-RING	P01.012.000	P01.016.000	P01.020.000	P01.025.000	P01.032.000
E	1,6		2,5		4,0
∅ Pillar	40	50	63	80	100
RÉFÉRENCES 1/2 SNAP-RING	P01.040.000	P01.050.000	P01.063.000	P01.080.000	P01.100.000
E	14,0		6,0		

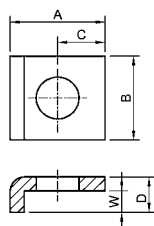
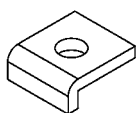

Compact retaining clamp for guide bush type BRO, ALU, ACI

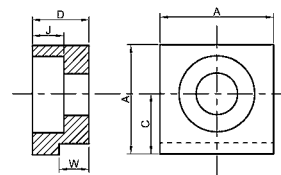
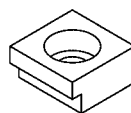

Compact retaining clamp B03.xxx.000 for pillar type RID

REFERENCES	B03.006.100	B03.008.100
A	14,5	20
B	16	18
C	7,5	10
W	3	4,5
D	6	7,5
J	-	-
Screw	A05.006.016	A05.008.020

B03.005.000	B03.006.000	B03.008.000	B03.010.000
14	18	22	26
-	-	-	-
7	9,5	12	15
3,75	4,75	5,75	9,75
7	9	11	18
4	5	7	10
A05.005.012	A05.006.020	A05.008.020	A05.010.025

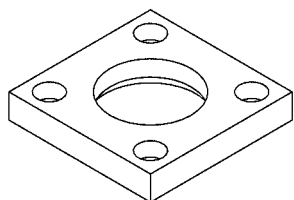

Square clamp for pillar type RI and RM

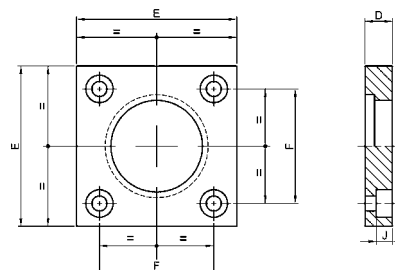

∅ Colonne	25	32	40	50	63	80	100
REFERENCES	BC.025	BC.032	BC.040	BC.050	BC.063	BC.080	BC.100
E	45	56	70	80	100	110	140
F	31	36	50	55	70	80	100
D	10	10	12	14	18	20	20
J	7	7	7	9	11	13	13
Screw	A05.005.012	A05.005.012	A05.005.012	A05.008.020	A05.010.025	A05.012.030	A05.012.030

ACCESSORIES

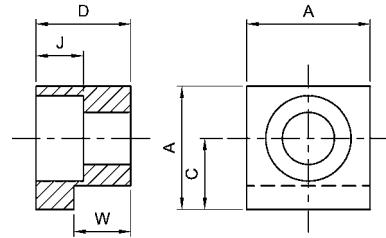
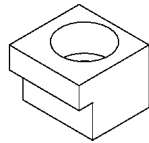

Compact retaining clamp for guide bush type BCA and BBEI

∅ Guide bush	12	16	20	25	32
REFERENCES	B05.005.012	B05.008.016	B05.010.020	B05.010.025	B05.010.032
A	18	22	26	26	26
C	9,5	12	15	15	15
W	8	10	12	16	20
D	12	16	20	25	32
J	5	8	10	10	10
Screw	A05.005.016	A05.008.020	A05.010.025	A05.010.030	A05.010.035

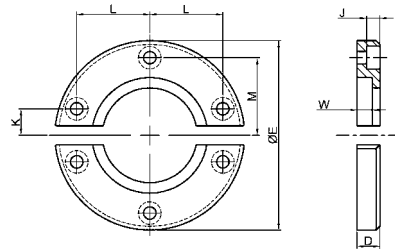
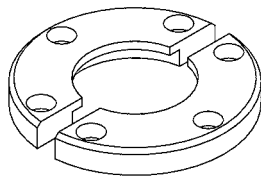

1/2 round retaining clamp for guid bush type BCA and BBEI

∅ Guide bush	20	25	32	40	50	63	80	100
REFERENCES	BDR.020	BDR.025	BDR.032	BDR.040	BDR.050	BDR.063	BDR.080	BDR.100
∅E	63	72	80	100	125	140	180	200
D	10	10	12	12	16	20	25	32
W	4	5	6	8	10	12	16	20
J	7	7	7	7	9	11	13	13
M	-	-	-	41	49	57,5	72	85
K	18	20	21	14	17	17	20	25
L	16	20	25	38,5	46	55	70	81
Screw	A05.005.012	A05.005.012	A05.005.012	A05.005.012	A05.008.025	A05.010.030	A05.012.040	A05.012.060
Quantity	4	4	4	6	6	6	6	6

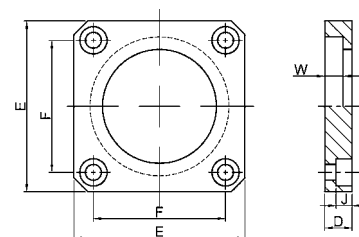
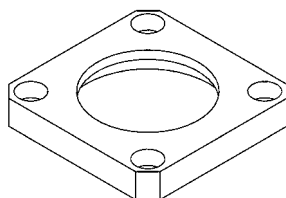

Square clamp for pillar type BCA and BBEI









∅ Bague	40	50	63	80
REFERENCES	BRCB.040	BRCB.050	BRCB.063	BRCB.080
E	75	85	100	120
F	58	65	80	98
D	12	16	16	20
J	7	9	9	12
W	8	10	12	16
Screw	A05.006.016	A05.008.020	A05.008.020	A05.008.020

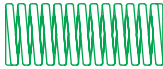

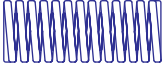

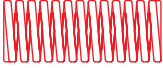

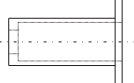

Springs

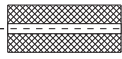

WIRE SPRINGS DIN ISO 10243

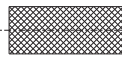
General Informations			179
S11			for light loads 180
R11			
S21			for medium loads 183
R21			
S26			for heavy loads 186
R26			
S36			for extra-heavy loads 189
FHx		Retainer	191

ELASTOMER SPRINGS

S66		Hollow rod	192
S67			
S68		Solid rod	192
S69			
S50		Elastomer springs 70 - Shore	193
S55		Elastomer springs 90 Shore	195

ACCESSORIES

S60		Guide shafts	197
S65		Washers	197

ASSEMBLY INSTRUCTIONS **198**

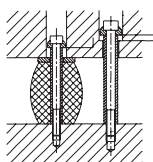

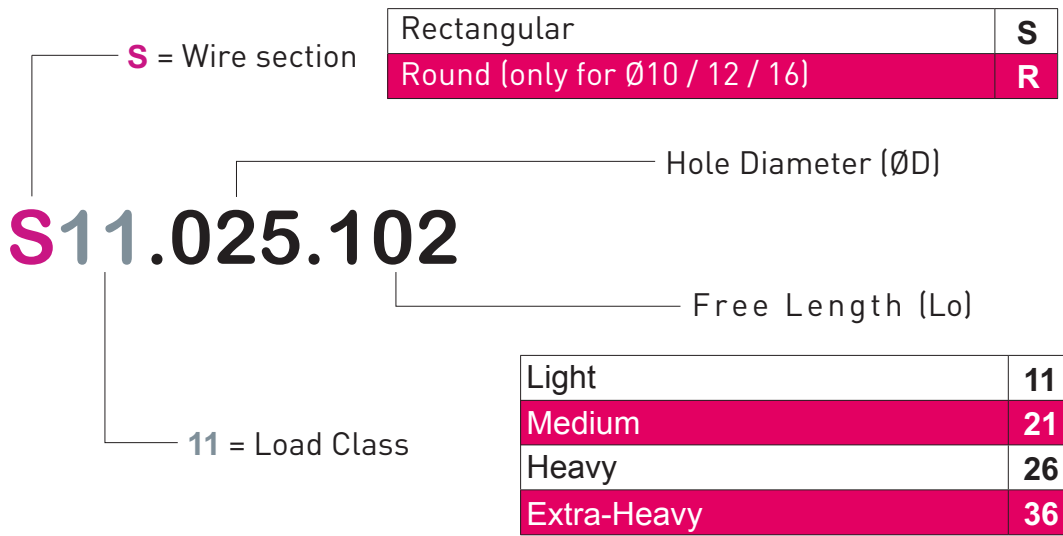

- Lo** = Free length
- S3** = Maximum operating deflection
- S2** = Total deflection recommended for average life
- S1** = Total deflection recommended for long life

(1) - The right sizing of the pre-load value is essential to satisfy a long life to the springs.

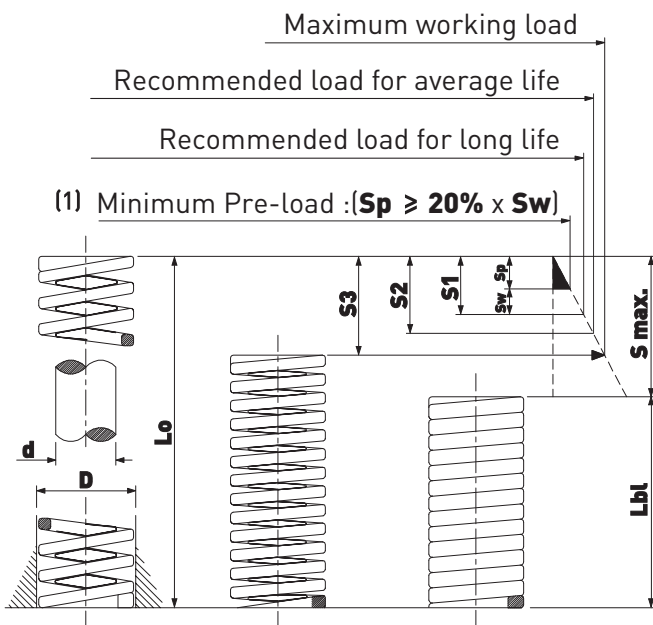

Load Class	11	21	26	36
S1 Total deflection recommended for long life	25% of L_o	25% of L_o	20% of L_o	17% of L_o
S2 Total deflection recommended for average life	30% of L_o	30% of L_o	25% of L_o	20% of L_o
S3 Maximum operating deflection	40% of L_o	37,5% of L_o	30% of L_o	25% of L_o

L_o : Free length

- Sw** = Effective deflection
 - Sp** = Pre-load
 - Lbl** = Total length solid condition
- $$S_w + S_p \leq S_3$$

We select the best steels (Chrome Vanadium Silicon Steels) to manufacture our springs, the same supplied for automotive valve springs.

We use drawn wire which guarantees best characteristics.

We manufacture our springs according to a strict procedure : after forming and heat treatment, we carry out shot peening to improve more the fatigue resistance.

We carefully grind the 2 faces to obtain a perfect perpendicularity at each step we carry out a strict inspection to guarantee you the greatest life of our springs.

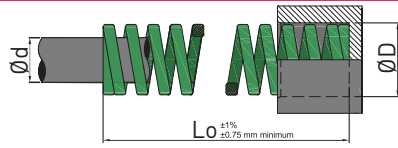

Diameters : 10 to 20mm
Rectangular wire



Hole Ø mm	Rod Ø mm	Free length mm	Reference	RATE (daN) required to deflect 1 mm	LOAD TABLE							
					S1 Total deflection recommended for long life (25% of Lo)		S2 Total deflection recommended for average life (30% of Lo)		S3 Maximum operating deflection (40% of Lo)		Total travel to solid	
					Load daN	Deflect. mm	Load daN	Deflect. mm	Load daN	Deflect. mm	Load daN	Deflect. mm
D	d	Lo	C	Load daN	Deflect. mm	Load daN	Deflect. mm	Load daN	Deflect. mm	Load daN	Deflect. mm	
10	5	25	S11.010.025	1,00	6,25	6,25	7,5	7,5	10,2	10,2	14,3	14,3
		32	S11.010.032	0,85	6,8	8	8,16	9,6	10,6	12,5	15,6	18,3
		38	S11.010.038	0,68	6,46	9,5	7,48	11	10,2	15	15,0	22
		44	S11.010.044	0,60	6,6	11	7,8	13	10,8	18	15,6	26
		51	S11.010.051	0,50	6,5	13	7,5	15	10,0	20	14,5	29
		64	S11.010.064	0,43	6,88	16	8,17	19	10,8	25	16,3	38
		76	S11.010.076	0,32	6,08	19	7,36	23	9,60	30	14,7	46
305	S11.010.305	0,11	8,36	76	10,01	91	13,4	122	19,6	178		
12,5	6,3	25	S11.012.025	1,79	11,09	6,2	13,42	7,5	18,3	10,2	24,3	13,6
		32	S11.012.032	1,64	13,12	8	15,74	9,6	20,5	12,5	30,0	18,3
		38	S11.012.038	1,36	12,92	9,5	14,96	11	20,4	15	29,9	22
		44	S11.012.044	1,21	13,31	11	15,73	13	21,8	18	31,5	26
		51	S11.012.051	1,14	14,82	13	17,1	15	22,8	20	34,2	30
		64	S11.012.064	0,93	14,88	16	17,67	19	23,3	25	35,3	38
		76	S11.012.076	0,71	13,49	19	16,33	23	21,3	30	31,2	44
89	S11.012.089	0,54	11,88	22	14,58	27	19,4	36	28,1	52		
305	S11.012.305	0,14	10,64	76	12,74	91	17,1	122	24,5	175		
16	8	25	S11.016.025	2,34	14,5	6,2	17,55	7,5	23,9	10,2	31,1	13,3
		32	S11.016.032	2,29	18,32	8	21,98	9,6	28,6	12,5	37,6	16,4
		38	S11.016.038	1,93	18,33	9,5	21,23	11	29,0	15	40,5	21
		44	S11.016.044	1,71	18,81	11	22,23	13	30,8	18	42,8	25
		51	S11.016.051	1,57	20,41	13	23,55	15	31,4	20	45,5	29
		64	S11.016.064	1,01	16,16	16	19,19	19	25,3	25	37,4	37
		76	S11.016.076	1,00	19,0	19	23	23	30,0	30	44,0	44
89	S11.016.089	0,86	18,92	22	23,22	27	30,1	35	45,6	53		
102	S11.016.102	0,78	20,28	26	24,18	31	32,0	41	47,6	61		
305	S11.016.305	0,25	19,0	76	22,75	91	30,5	122	46,0	184		
20	10	25	S11.020.025	5,5	35	6,2	42	7,5	57	10,2	73	13
		32	S11.020.032	4,2	34	8	41	9,6	54	12,5	69	16
		38	S11.020.038	3,3	32	9,5	37	11	51	15	65	19
		44	S11.020.044	2,77	31	11	37	13	51	18	64	23
		51	S11.020.051	2,45	32	13	37	15	50	20	64	26
		64	S11.020.064	1,90	31	16	37	19	49	25	62	32
		76	S11.020.076	1,61	31	19	37	23	48	30	62	40
		89	S11.020.089	1,34	30	22	36	27	47	35	62	46
		102	S11.020.102	1,18	31	26	37	31	48	41	62	53
		115	S11.020.115	1,04	30	29	36	35	48	46	62	60
		127	S11.020.127	0,93	30	32	35	38	47	51	62	67
		140	S11.020.140	0,85	30	35	36	42	48	56	62	73
		152	S11.020.152	0,79	30	38	36	46	48	61	62	81
305	S11.020.305	0,38	29	76	35	91	46	122	61	162		

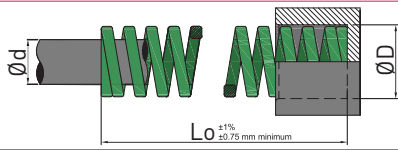

Diameters : 25 to 63mm
Rectangular wire



Hole Ø mm	Rod Ø mm	Free length mm	Reference	RATE (daN) required to deflect 1 mm	LOAD TABLE							
					S1 Total deflection recommended for long life [25% of Lo]		S2 Total deflection recommended for average life [30% of Lo]		S3 Maximum operating deflection [40% of Lo]		Total travel to solid	
					Load daN	Deflect. mm	Load daN	Deflect. mm	Load daN	Deflect. mm	Load daN	Deflect. mm
25	12,5	25	S11.025.025	10,7	66	6,2	80	7,5	109	10,2	139	13
		32	S11.025.032	8,1	65	8	78	9,6	101	12,5	130	16
		38	S11.025.038	6,5	62	9,5	72	11	98	15	124	19
		44	S11.025.044	5,3	58	11	69	13	95	18	122	23
		51	S11.025.051	4,6	60	13	69	15	92	20	115	25
		64	S11.025.064	3,6	58	16	68	19	90	25	112	31
		76	S11.025.076	2,92	56	19	67	23	88	30	112	39
		89	S11.025.089	2,46	54	22	66	27	86	35	112	46
		102	S11.025.102	2,12	55	26	66	31	87	41	110	52
		115	S11.025.115	1,87	54	29	65	35	86	46	110	59
		127	S11.025.127	1,67	53	32	63	38	85	51	110	66
		140	S11.025.140	1,52	53	35	64	42	85	56	112	74
		152	S11.025.152	1,40	53	38	64	46	85	61	110	80
		178	S11.025.178	1,20	53	44	64	53	85	71	110	93
		203	S11.025.203	1,05	53	51	64	61	85	81	110	107
		305	S11.025.305	0,70	53	76	64	91	85	122	110	160
32	16	38	S11.032.038	10,10	96	9,5	111	11	152	15	192	19
		44	S11.032.044	8,3	91	11	108	13	149	18	183	22
		51	S11.032.051	7,1	92	13	107	15	142	20	178	25
		64	S11.032.064	5,5	88	16	105	19	138	25	176	32
		76	S11.032.076	4,6	87	19	106	23	138	30	175	39
		89	S11.032.089	3,9	86	22	105	27	137	35	175	45
		102	S11.032.102	3,4	88	26	105	31	139	41	175	52
		115	S11.032.115	3,0	87	29	105	35	138	46	174	58
		127	S11.032.127	2,62	84	32	100	38	134	51	170	65
		140	S11.032.140	2,38	83	35	100	42	133	56	171	72
		152	S11.032.152	2,19	83	38	101	46	134	61	170	78
		178	S11.032.178	1,82	80	44	96	53	129	71	165	88
		203	S11.032.203	1,59	81	51	97	61	129	81	165	104
		254	S11.032.254	1,25	80	64	95	76	128	102	163	130
		305	S11.032.305	1,04	79	76	95	91	127	122	161	155
40	20	51	S11.040.051	10,6	138	13	159	15	212	20	265	25
		64	S11.040.064	8,0	128	16	152	19	200	25	256	32
		76	S11.040.076	6,6	125	19	152	23	198	30	250	38
		89	S11.040.089	5,6	123	22	151	27	196	35	250	45
		102	S11.040.102	4,8	125	26	149	31	197	41	245	51
		115	S11.040.115	4,2	122	29	147	35	193	46	243	58
		127	S11.040.127	3,8	122	32	144	38	194	51	243	65
		140	S11.040.140	3,4	119	35	143	42	190	56	241	71
		152	S11.040.152	3,1	118	38	143	46	189	61	241	78
		178	S11.040.178	2,6	114	44	138	53	185	71	240	92
		203	S11.040.203	2,3	117	51	140	61	186	81	240	105
		254	S11.040.254	1,80	115	64	137	76	184	102	236	131
		305	S11.040.305	1,48	112	76	135	91	181	122	226	157
50	25	64	S11.050.064	15,7	251	16	298	19	393	25	502	32
		76	S11.050.076	12,6	239	19	290	23	378	30	491	39
		89	S11.050.089	10,5	231	22	284	27	368	35	473	45
		102	S11.050.102	9,0	234	26	279	31	369	41	468	52
		115	S11.050.115	7,8	226	29	273	35	359	46	455	58
		127	S11.050.127	7,0	224	32	266	38	357	51	455	65
		140	S11.050.140	6,3	221	35	265	42	353	56	446	72
		152	S11.050.152	5,7	217	38	262	46	348	61	445	78
		178	S11.050.178	4,8	211	44	254	53	341	71	441	92
		203	S11.050.203	4,2	214	51	256	61	340	81	437	104
		254	S11.050.254	3,3	211	64	251	76	337	102	429	130
		305	S11.050.305	2,7	205	76	246	91	329	122	421	156
63	38	76	S11.063.076	19,3	367	19	444	23	579	30	733	38
		89	S11.063.089	15,8	348	22	427	27	553	35	695	44
		102	S11.063.102	13,4	348	26	415	31	549	41	670	50
		115	S11.063.115	11,6	336	29	406	35	534	46	661	57
		127	S11.063.127	10,2	326	32	388	38	520	51	653	64
		152	S11.063.152	8,4	319	38	386	46	512	61	638	76
		178	S11.063.178	7,0	308	44	371	53	497	71	623	89
		203	S11.063.203	6,0	306	51	366	61	486	81	612	102
		254	S11.063.254	4,7	301	64	357	76	479	102	592	126
		305	S11.063.305	3,9	296	76	355	91	476	122	592	152

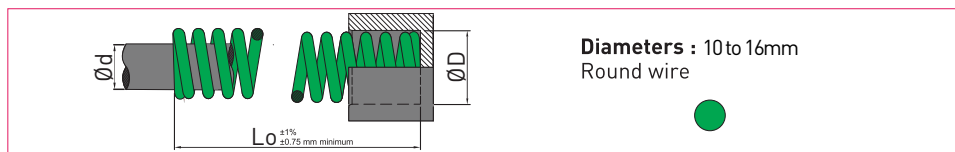

Hole Ø mm	Rod Ø mm	Free length mm	Reference	RATE (daN) required to deflect 1 mm	LOAD TABLE							
					S1 Total deflection recommended for long life (25% of Lo)		S2 Total deflection recommended for average life (30% of Lo)		S3 Maximum operating deflection (40% of Lo)		Total travel to solid	
					Load daN	Deflect. mm	Load daN	Deflect. mm	Load daN	Deflect. mm	Load daN	Deflect. mm
D	d	Lo	C									
10	5	25	R11.010.025	0,45	2,8	6,2	3,4	7,5	4,6	10,2	5,8	13
		32	R11.010.032	0,35	2,8	8	3,4	9,6	4,4	12,5	5,6	16
		38	R11.010.038	0,28	2,7	9,5	3,1	11	4,2	15	5,6	20
		44	R11.010.044	0,24	2,6	11	3,1	13	4,3	18	5,6	23
		51	R11.010.051	0,21	2,7	13	3,1	15	4,2	20	5,6	27
		64	R11.010.064	0,16	2,6	16	3	19	4	25	5,5	34
		76	R11.010.076	0,13	2,5	19	3	23	3,9	30	5,3	40
305	R11.010.305	0,03	2,3	76	2,7	91	3,7	122	4,9	163		
12,5	6,3	25	R11.012.025	0,89	5,5	6,2	6,7	7,5	9,1	10,2	11,6	13
		32	R11.012.032	0,67	5,4	8	6,4	9,6	8,4	12,5	11,4	17
		38	R11.012.038	0,55	5,2	9,5	6,1	11	8,3	15	11	20
		44	R11.012.044	0,46	5,1	11	6	13	8,3	18	10,6	23
		51	R11.012.051	0,39	5,1	13	5,9	15	7,8	20	10,5	27
		64	R11.012.064	0,30	4,8	16	5,7	19	7,5	25	10,5	35
		76	R11.012.076	0,25	4,8	19	5,7	23	7,5	30	10,3	41
89	R11.012.089	0,21	4,6	22	5,7	27	7,6	36	10,3	49		
305	R11.012.305	0,06	4,6	76	5,5	91	7,3	122	10	166		
16	8	25	R11.016.025	1,79	11,1	6,2	13,4	7,5	18,3	10,2	23	13
		32	R11.016.032	1,34	10,7	8	12,9	9,6	16,8	12,5	21	16
		38	R11.016.038	1,06	10,1	9,5	11,7	11	15,9	15	21	20
		44	R11.016.044	0,87	9,6	11	11,3	13	15,7	18	20	23
		51	R11.016.051	0,76	9,9	13	11,4	15	15,2	20	20	27
		64	R11.016.064	0,59	9,4	16	11,2	19	14,8	25	20	34
		76	R11.016.076	0,48	9,1	19	11	23	14,4	30	19,7	41
		89	R11.016.089	0,40	8,8	22	10,8	27	14	35	19,6	49
		102	R11.016.102	0,35	9,1	26	10,8	31	14,3	41	19,6	56
305	R11.016.305	0,11	8,4	76	10	91	13,4	122	18,7	170		

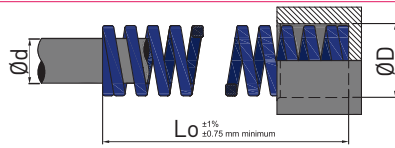

Diameters : 10 to 20mm
Rectangular wire



Hole Ø mm	Rod Ø mm	Free length mm	Reference	RATE (daN) required to deflect 1 mm	LOAD TABLE							
					S1 Total deflection recommended for long life (25% of Lo)		S2 Total deflection recommended for average life (30% of Lo)		S3 Maximum operating deflection (37,5% of Lo)		Total travel to solid	
					Load daN	Deflect. mm	Load daN	Deflect. mm	Load daN	Deflect. mm	Load daN	Deflect. mm
D	d	Lo	C									
10	5	25	S21.010.025	1,60	9,92	6,2	12,0	7,5	15,0	9,4	18,6	11,6
		32	S21.010.032	1,30	10,4	8	12,48	9,6	15,6	12	20,7	15,9
		38	S21.010.038	1,19	11,30	9,5	13,09	11	16,7	14	23,1	19,4
		44	S21.010.044	1,03	11,33	11	13,39	13	17,0	16,5	23,7	23
		51	S21.010.051	0,89	11,57	13	13,35	15	16,9	19	23,1	26
		64	S21.010.064	0,75	12,0	16	14,25	19	18,0	24	24,8	33
		76	S21.010.076	0,53	10,07	19	12,19	23	14,8	28	21,2	40
		305	S21.010.305	0,16	12,16	76	14,56	91	18,2	114	24,6	154
12,5	6,3	25	S21.012.025	3,00	18,6	6,2	22,5	7,5	28,2	9,4	38,1	12,7
		32	S21.012.032	2,48	19,84	8	23,8	9,6	29,8	12	39,9	16,1
		38	S21.012.038	2,14	20,33	9,5	23,54	11	30,0	14	42,6	19,9
		44	S21.012.044	1,85	20,35	11	24,05	13	30,5	16,5	42,6	23
		51	S21.012.051	1,55	20,15	13	23,25	15	29,5	19	41,9	27
		64	S21.012.064	1,21	19,36	16	22,99	19	29,0	24	39,9	33
		76	S21.012.076	1,02	19,38	19	23,46	23	28,6	28	39,8	39
		89	S21.012.089	0,84	18,48	22	22,68	27	27,7	33	38,6	46
305	S21.012.305	0,21	15,96	76	19,11	91	23,9	114	33,8	161		
16	8	25	S21.016.025	4,94	30,62	6,2	37,05	7,5	46,4	9,4	55,8	11,3
		32	S21.016.032	3,71	29,68	8	35,61	9,6	44,5	12	50,5	13,6
		38	S21.016.038	3,39	32,2	9,5	37,29	11	47,5	14	59,7	17,6
		44	S21.016.044	3,00	33,0	11	39,0	13	49,5	16,5	63,0	21
		51	S21.016.051	2,64	34,32	13	39,6	15	50,2	19	66,0	25
		64	S21.016.064	2,05	32,8	16	38,95	19	49,2	24	63,6	31
		76	S21.016.076	1,78	33,82	19	40,94	23	49,8	28	67,6	38
		89	S21.016.089	1,52	33,44	22	41,04	27	50,2	33	68,4	45
102	S21.016.102	1,35	35,1	26	41,85	31	51,3	38	70,2	52		
305	S21.016.305	0,48	36,48	76	43,68	91	54,9	114	73,4	153		
20	10	25	S21.020.025	9,02	55,9	6,2	67,6	7,5	84,8	9,4	99	11
		32	S21.020.032	6,67	53,4	8	64	9,6	80	12	90	13
		38	S21.020.038	5,48	52,1	9,5	60,3	11	76,7	14	88	16
		44	S21.020.044	4,45	49	11	57,9	13	73,4	16,5	85	19
		51	S21.020.051	3,94	51,2	13	59,1	15	74,9	19	83	21
		64	S21.020.064	3,03	48,5	16	57,6	19	72,7	24	82	27
		76	S21.020.076	2,49	47,3	19	57,3	23	69,7	28	82	33
		89	S21.020.089	2,14	47,1	22	57,8	27	70,6	33	82	39
		102	S21.020.102	1,84	47,8	26	57	31	69,9	38	81	44
		115	S21.020.115	1,63	47,3	29	57	35	70,1	43	80	49
		127	S21.020.127	1,46	46,7	32	55,5	38	70,1	48	80	55
		140	S21.020.140	1,32	46	35	55	42	69	52	80	61
		152	S21.020.152	1,21	46	38	55,7	46	69	57	80	66
		305	S21.020.305	0,61	46,4	76	55,5	91	69,5	114	80	136

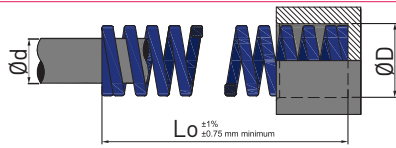

Diameters : 25 to 63mm
Rectangular wire



Hole Ø mm	Rod Ø mm	Free length mm	Reference	RATE (daN) required to deflect 1 mm	LOAD TABLE									
					S1 Total deflection recommended for long life (25% of Lo)		S2 Total deflection recommended for average life (30% of Lo)		S3 Maximum operating deflection (37,5% of Lo)		Total travel to solid			
					Load daN	Deflect. mm	Load daN	Deflect. mm	Load daN	Deflect. mm	Load daN	Deflect. mm		
D	d	Lo	C	C	Load daN	Deflect. mm	Load daN	Deflect. mm	Load daN	Deflect. mm	Load daN	Deflect. mm		
25	12,5	25	S21.025.025	16,7	104	6,2	125	7,5	157	9,4	184	11		
		32	S21.025.032	12,5	100	8	120	9,6	150	12	170	13		
		38	S21.025.038	9,9	94	9,5	109	11	139	14	158	16		
		44	S21.025.044	8,3	91	11	108	13	137	16,5	158	19		
		51	S21.025.051	7,2	94	13	108	15	137	19	156	21		
		64	S21.025.064	5,5	88	16	105	19	132	24	151	27		
		76	S21.025.076	4,5	86	19	104	23	126	28	148	33		
		89	S21.025.089	3,8	84	22	103	27	125	33	148	39		
		102	S21.025.102	3,3	86	26	102	31	125	38	145	44		
		115	S21.025.115	2,91	84	29	102	35	125	43	145	60		
		127	S21.025.127	2,63	84	32	100	38	126	48	145	66		
		140	S21.025.140	2,36	83	35	99	42	123	52	149	63		
		152	S21.025.152	2,17	82	38	100	46	124	57	145	67		
		178	S21.025.178	1,84	81	44	98	53	123	67	145	79		
		203	S21.025.203	1,60	82	51	98	61	122	76	144	90		
305	S21.025.305	1,05	80	76	96	91	120	114	142	135				
32	16	38	S21.032.038	16,6	158	9,5	183	11	232	14	266	16		
		44	S21.032.044	13,6	150	11	177	13	224	16,5	258	19		
		51	S21.032.051	11,6	151	13	174	15	220	19	244	21		
		64	S21.032.064	8,8	141	16	167	19	211	24	238	27		
		76	S21.032.076	7,1	135	19	163	23	199	28	227	32		
		89	S21.032.089	6,0	132	22	162	27	198	33	222	37		
		102	S21.032.102	5,2	135	26	161	31	198	38	222	43		
		115	S21.032.115	4,6	133	29	161	35	198	43	222	49		
		127	S21.032.127	4,2	134	32	160	38	202	48	222	55		
		140	S21.032.140	3,7	130	35	155	42	192	52	222	60		
		152	S21.032.152	3,4	129	38	156	46	194	57	222	66		
		178	S21.032.178	2,91	128	44	154	53	195	67	222	77		
		203	S21.032.203	2,52	129	51	154	61	192	76	222	88		
		254	S21.032.254	2,00	128	64	152	76	190	95	220	110		
		305	S21.032.305	1,66	126	76	151	91	189	114	220	133		
40	20	51	S21.040.051	17,1	222	13	257	15	325	19	359	21		
		64	S21.040.064	12,9	206	16	245	19	310	24	335	26		
		76	S21.040.076	10,5	200	19	242	23	294	28	335	32		
		89	S21.040.089	8,8	194	22	238	27	290	33	326	37		
		102	S21.040.102	7,6	198	26	236	31	289	38	326	43		
		115	S21.040.115	6,7	194	29	235	35	288	43	322	48		
		127	S21.040.127	6,0	192	32	228	38	288	48	322	54		
		140	S21.040.140	5,4	189	35	227	42	281	52	319	59		
		152	S21.040.152	4,9	186	38	225	46	279	57	318	65		
		178	S21.040.178	4,2	185	44	223	53	281	67	318	76		
		203	S21.040.203	3,6	184	51	220	61	274	76	315	87		
		254	S21.040.254	2,89	185	64	220	76	275	95	315	110		
		305	S21.040.305	2,38	181	76	217	91	271	114	312	131		
		50	25	64	S21.050.064	21,2	339	16	403	19	509	24	566	27
				76	S21.050.076	16,7	317	19	384	23	468	28	532	32
89	S21.050.089			14,0	308	22	378	27	462	33	525	37		
102	S21.050.102			12,2	317	26	378	31	464	38	525	43		
115	S21.050.115			10,7	310	29	375	35	460	43	525	49		
127	S21.050.127			9,5	304	32	361	38	456	48	513	54		
140	S21.050.140			8,6	301	35	361	42	447	52	507	59		
152	S21.050.152			7,8	296	38	359	46	445	57	508	66		
178	S21.050.178			6,6	290	44	350	53	442	67	506	77		
203	S21.050.203			5,7	291	51	348	61	433	76	506	88		
229	S21.050.229			5,1	291	57	352	69	439	86	506	100		
254	S21.050.254			4,6	294	64	350	76	437	95	506	117		
305	S21.050.305			3,8	289	76	346	91	433	114	504	134		
63	38			76	S21.063.076	30,4	578	19	699	23	851	28	973	32
				89	S21.063.089	25,0	550	22	675	27	825	33	950	38
		102	S21.063.102	21,2	551	26	657	31	806	38	933	44		
		115	S21.063.115	18,6	539	29	651	35	800	43	930	50		
		127	S21.063.127	16,4	525	32	623	38	787	48	918	56		
		152	S21.063.152	13,3	505	38	612	46	758	57	891	67		
		178	S21.063.178	11,2	493	44	594	53	750	67	874	78		
		203	S21.063.203	9,6	490	51	586	61	730	76	865	90		
		229	S21.063.229	8,5	485	57	587	69	731	86	865	102		
		254	S21.063.254	7,7	493	64	585	76	732	95	865	115		
		305	S21.063.305	6,3	479	76	573	91	718	114	865	138		

1 daN = 1.0197 kg

Note: Need for internal guide (Lo ≥ 4xØ)

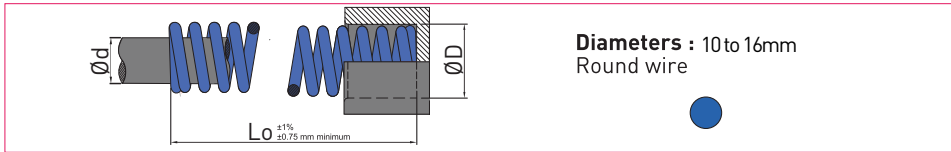

Hole Ø mm	Rod Ø mm	Free length mm	Reference	RATE (daN) required to deflect 1 mm	LOAD TABLE							
					S1 Total deflection recommended for long life (25% of Lo)		S2 Total deflection recommended for average life (30% of Lo)		S3 Maximum operating deflection (37,5% of Lo)		Total travel to solid	
					Load daN	Deflect. mm	Load daN	Deflect. mm	Load daN	Deflect. mm	Load daN	Deflect. mm
D	d	Lo	C									
10	5	25	R21.010.025	1,26	7,8	6,2	9,5	7,5	11,8	9,4	13	11
		32	R21.010.032	0,98	7,8	8	9,4	9,6	11,8	12	12,8	13
		38	R21.010.038	0,79	7,5	9,5	8,7	11	11,1	14	12,6	16
		44	R21.010.044	0,66	7,3	11	8,6	13	10,9	16,5	12,5	19
		51	R21.010.051	0,57	7,4	13	8,6	15	10,8	19	12,2	21
		64	R21.010.064	0,45	7,2	16	8,6	19	10,8	24	12,2	27
		76	R21.010.076	0,37	7,0	19	8,5	23	10,4	28	12,2	33
		305	R21.010.305	0,09	6,8	76	8,2	91	10,3	114	12,2	136
12,5	6,3	25	R21.012.025	2,28	14,1	6,2	17,1	7,5	21,4	9,4	23	11
		32	R21.012.032	1,75	14	8	16,8	9,6	21	12	22,8	13
		38	R21.012.038	1,43	13,6	9,5	15,7	11	20	14	22,8	16
		44	R21.012.044	1,18	13	11	15,3	13	19,5	16,5	22,5	19
		51	R21.012.051	1,02	13,3	13	15,3	15	19,4	19	22,4	22
		64	R21.012.064	0,79	12,6	16	15	19	19	24	22,1	28
		76	R21.012.076	0,65	12,4	19	15	23	18,2	28	22	34
		89	R21.012.089	0,55	12,1	22	14,9	27	18,2	33	22,6	41
305	R21.012.305	0,15	11,4	76	13,7	91	17,1	114	21,6	144		
16	8	25	R21.016.025	3,38	20,6	6,2	25,4	7,5	31,8	9,4	33,8	11
		32	R21.016.032	2,50	20	8	24	9,6	30	12	32,8	13
		38	R21.016.038	2,01	19,1	9,5	22,1	11	28,1	14	32,2	16
		44	R21.016.044	1,67	18,4	11	21,7	13	27,6	16,5	30,9	19
		51	R21.016.051	1,42	18,5	13	21,3	15	27	19	30	21
		64	R21.016.064	1,10	17,6	16	20,9	19	26,4	24	29,7	27
		76	R21.016.076	0,90	17,1	19	20,7	23	25,2	28	29,7	33
		89	R21.016.089	0,76	16,7	22	20,5	27	25,1	33	29,6	39
		102	R21.016.102	0,66	17,2	26	20,5	31	25,1	38	29,6	45
		305	R21.016.305	0,21	16	76	19,1	91	23,9	114	29	138

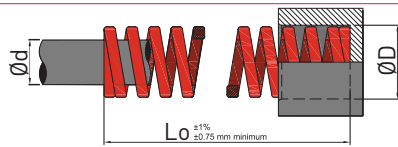

Diameters : 10 to 20mm
Rectangular wire



Hole Ø mm	Rod Ø mm	Free length mm	Reference	RATE (daN) required to deflect 1 mm	LOAD TABLE							
					S1 Total deflection recommended for long life (20% of Lo)		S2 Total deflection recommended for average life (25% of Lo)		S3 Maximum operating deflection (30% of Lo)		Total travel to solid	
					Load daN	Deflect. mm	Load daN	Deflect. mm	Load daN	Deflect. mm	Load daN	Deflect. mm
D	d	Lo	C									
10	5	25	S26.010.025	2,21	11,05	5	13,7	6,2	16,6	7,5	20,6	9,3
		32	S26.010.032	1,75	11,37	6,5	14	8	16,8	9,6	20,8	11,9
		38	S26.010.038	1,71	12,82	7,5	16,24	9,5	18,8	11	28,6	16,7
		44	S26.010.044	1,50	13,5	9	16,5	11	19,5	13	29,7	19,8
		51	S26.010.051	1,28	12,8	10	16,64	13	19,2	15	28,2	22
		64	S26.010.064	1,07	13,91	13	17,12	16	20,3	19	31,0	29
		76	S26.010.076	0,75	11,25	15	14,25	19	17,3	23	24,8	33
305	S26.010.305	0,21	12,81	61	15,96	76	19,1	91	28,1	134		
12,5	6,3	25	S26.012.025	4,21	21,05	5	26,10	6,2	31,6	7,5	46,7	11,1
		32	S26.012.032	3,32	21,58	6,5	26,56	8	31,9	9,6	47,5	14,3
		38	S26.012.038	2,93	21,97	7,5	27,83	9,5	32,2	11	51,6	17,6
		44	S26.012.044	2,46	22,14	9	27,06	11	32,0	13	51,7	21
		51	S26.012.051	1,96	19,60	10	25,48	13	29,4	15	47,0	24
		64	S26.012.064	1,50	19,50	13	24,00	16	28,5	19	43,5	29
		76	S26.012.076	1,32	19,80	15	25,08	19	30,4	23	48,8	37
89	S26.012.089	1,14	20,52	18	25,08	22	30,8	27	47,9	42		
305	S26.012.305	0,28	17,08	61	21,28	76	25,5	91	40,6	145		
16	8	25	S26.016.025	7,57	37,85	5	46,93	6,2	56,8	7,5	71,2	9,4
		32	S26.016.032	5,28	34,32	6,5	42,24	8	50,7	9,6	67,1	12,7
		38	S26.016.038	4,85	36,37	7,5	46,07	9,5	53,4	11	74,2	15,3
		44	S26.016.044	4,28	38,52	9	47,08	11	55,6	13	81,7	19,1
		51	S26.016.051	3,71	37,10	10	48,23	13	55,7	15	77,9	21
		64	S26.016.064	3,03	39,39	13	48,48	16	57,6	19	81,8	27
		76	S26.016.076	2,57	38,55	15	48,83	19	59,1	23	87,4	34
89	S26.016.089	2,17	39,06	18	47,74	22	58,6	27	86,8	40		
102	S26.016.102	1,93	38,60	20	50,18	26	59,8	31	88,8	46		
305	S26.016.305	0,71	43,31	61	53,96	76	64,6	91	98,0	138		
20	10	25	S26.020.025	23,1	116	5	143	6,2	173	7,5	194	8,4
		32	S26.020.032	17,4	113	6,5	139	8	167	9,6	183	10,5
		38	S26.020.038	13,9	106	7,5	132	9,5	153	11	174	12,5
		44	S26.020.044	11,4	103	9	127	11	148	13	165	14,5
		51	S26.020.051	9,8	101	10	127	13	147	15	162	16,5
		64	S26.020.064	7,7	100	13	128	16	146	19	162	21
		76	S26.020.076	6,3	97	15	120	19	145	23	162	26
		89	S26.020.089	5,4	97	18	120	22	145	27	162	30
		102	S26.020.102	4,7	94	20	120	26	145	31	162	35
		115	S26.020.115	4,1	94	23	119	29	144	35	162	40
		127	S26.020.127	3,7	93	25	118	32	141	38	162	44
		140	S26.020.140	3,4	95	28	119	35	143	42	167	49
		152	S26.020.152	3,08	92	30	117	38	141	46	162	53
305	S26.020.305	1,50	91	61	114	76	137	91	162	108		



Diameters : 25 to 50mm
Rectangular wire



Hole Ø mm	Rod Ø mm	Free length mm	Reference	RATE (daN) required to deflect 1 mm	LOAD TABLE							
					S1 Total deflection recommended for long life (20% of Lo)		S2 Total deflection recommended for average life (25% of Lo)		S3 Maximum operating deflection (30% of Lo)		Total travel to solid	
					Load daN	Deflect. mm	Load daN	Deflect. mm	Load daN	Deflect. mm	Load daN	Deflect. mm
D	d	Lo	C	C	Load daN	Deflect. mm	Load daN	Deflect. mm	Load daN	Deflect. mm	Load daN	Deflect. mm
25	12,5	32	S26.025.032	27,6	179	6,5	221	8	265	9,6	290	10,5
		38	S26.025.038	22,0	165	7,5	209	9,5	242	11	286	13
		44	S26.025.044	18,4	166	9	202	11	239	13	285	15,5
		51	S26.025.051	15,7	157	10	204	13	236	15	283	18
		64	S26.025.064	12,2	159	13	195	16	232	19	275	22,5
		76	S26.025.076	10,0	150	15	190	19	230	23	275	27,5
		89	S26.025.089	8,4	151	18	185	22	227	27	275	32,5
		102	S26.025.102	7,4	148	20	192	26	229	31	275	37,5
		115	S26.025.115	6,5	150	23	189	29	228	35	275	42,7
		127	S26.025.127	5,8	145	25	186	32	220	38	273	47
		140	S26.025.140	5,2	146	28	182	35	218	42	270	52
		152	S26.025.152	4,8	144	30	182	38	221	46	273	57,5
		178	S26.025.178	4,1	148	36	180	44	217	53	273	68
203	S26.025.203	3,59	144	40	183	51	219	61	273	77		
305	S26.025.305	2,42	148	61	184	76	220	91	273	115		
32	16	38	S26.032.038	37,6	282	7,5	357	9,5	414	11	451	12
		44	S26.032.044	31,0	279	9	341	11	403	13	440	14
		51	S26.032.051	26,3	263	10	342	13	394	15	435	16,5
		64	S26.032.064	20,5	267	13	328	16	389	19	435	21,5
		76	S26.032.076	16,6	249	15	315	19	382	23	430	26
		89	S26.032.089	13,9	250	18	306	22	375	27	425	30,5
		102	S26.032.102	12,1	242	20	315	26	375	31	425	35,5
		115	S26.032.115	10,6	244	23	307	29	371	35	425	40,5
		127	S26.032.127	9,6	240	25	307	32	365	38	425	45
		140	S26.032.140	8,6	241	28	301	35	361	42	430	50
		152	S26.032.152	7,9	237	30	300	38	363	46	425	54
		178	S26.032.178	6,7	241	36	295	44	355	53	420	63
		203	S26.032.203	5,8	232	40	296	51	354	61	420	72
254	S26.032.254	4,6	235	51	294	64	350	76	420	92		
305	S26.032.305	3,8	232	61	289	76	346	91	420	110		
40	20	51	S26.040.051	34,9	349	10	454	13	524	15	593	17
		64	S26.040.064	26,6	346	13	426	16	505	19	585	22
		76	S26.040.076	21,5	323	15	409	19	495	23	580	27
		89	S26.040.089	18,0	324	18	396	22	486	27	575	32
		102	S26.040.102	15,7	314	20	408	26	487	31	575	37
		115	S26.040.115	13,8	317	23	400	29	483	35	575	42
		127	S26.040.127	12,4	310	25	397	32	471	38	575	47
		140	S26.040.140	11,3	316	28	396	35	475	42	588	52
		152	S26.040.152	10,2	306	30	388	38	469	46	575	57,5
		178	S26.040.178	8,7	313	36	383	44	461	53	575	67
		203	S26.040.203	7,6	304	40	388	51	464	61	575	76
		254	S26.040.254	6,0	306	51	384	64	456	76	575	97
		305	S26.040.305	5,0	305	61	380	76	455	91	575	116
50	25	64	S26.050.064	42,3	550	13	677	16	804	19	910	21,5
		76	S26.050.076	33,8	507	15	642	19	777	23	879	26
		89	S26.050.089	28,1	506	18	618	22	759	27	860	30,5
		102	S26.050.102	24,5	490	20	637	26	760	31	860	35
		115	S26.050.115	21,5	495	23	624	29	753	35	860	40
		127	S26.050.127	18,9	473	25	605	32	718	38	850	45
		140	S26.050.140	16,9	473	28	592	35	710	42	845	50
		152	S26.050.152	15,4	462	30	585	38	708	46	830	54
		178	S26.050.178	13,2	475	36	581	44	700	53	830	64
		203	S26.050.203	11,5	460	40	587	51	701	61	830	72,5
		254	S26.050.254	9,0	459	51	576	64	684	76	825	92
		305	S26.050.305	7,5	457	61	570	76	683	91	825	112

1 daN = 1.0197 kg

Note: Need for internal guide(Lo ≥ 4xD)

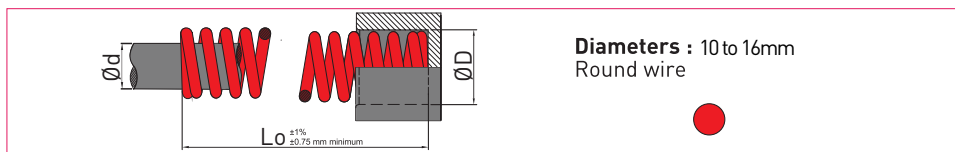

Hole Ø mm	Rod Ø mm	Free length mm	Reference	RATE (daN) required to deflect 1 mm	LOAD TABLE							
					S1 Total deflection recommended for long life (20% of Lo)		S2 Total deflection recommended for average life (25% of Lo)		S3 Maximum operating deflection (30% of Lo)		Total travel to solid	
					Load daN	Deflect. mm	Load daN	Deflect. mm	Load daN	Deflect. mm	Load daN	Deflect. mm
D	d	Lo	C									
10	5	25	R26.010.025	2,13	10,5	5	13	6,2	16	7,5	19	8,9
		32	R26.010.032	1,64	10,5	6,5	13	8	15,5	9,6	19	11,7
		38	R26.010.038	1,33	10	7,5	12,5	9,5	14,5	11	18,5	14
		44	R26.010.044	1,13	10	9	12,5	11	14,5	13	18,5	17
		51	R26.010.051	0,98	10	10	12,5	13	14,5	15	18,5	19
		64	R26.010.064	0,78	10	13	12,5	16	14,5	19	18,5	25
		76	R26.010.076	0,63	9,5	15	12	19	14,5	23	18	29
		305	R26.010.305	0,15	9	61	11,5	76	13,5	91	18	120
12,5	6,3	25	R26.012.025	3,9	19,5	5	24	6,2	29	7,5	34	8,7
		32	R26.012.032	3,0	19,5	6,5	24	8	29	9,6	33	11,0
		38	R26.012.038	2,42	18	7,5	23	9,5	27	11	32	13,5
		44	R26.012.044	2,01	18	9	22	11	26	13	32	16
		51	R26.012.051	1,77	18	10	23	13	27	15	32	19
		64	R26.012.064	1,38	18	13	22	16	26	19	32	24
		76	R26.012.076	1,14	17	15	21,5	19	26	23	32	29
		89	R26.012.089	0,96	17,3	18	21,1	22	25,9	27	32	33
305	R26.012.305	0,27	16,5	61	20,5	76	24,5	91	32	120		
16	8	25	R26.016.025	8,7	44	5	54	6,2	65	7,5	76	8,7
		32	R26.016.032	6,4	42	6,5	51	8	61	9,6	70	11
		38	R26.016.038	5,2	39	7,5	49	9,5	57	11	70	13,7
		44	R26.016.044	4,2	38	9	46	11	55	13	66	15,7
		51	R26.016.051	3,64	36	10	47	13	55	15	66	18,5
		64	R26.016.064	2,84	37	13	45	16	54	19	66	23,5
		76	R26.016.076	2,33	35	15	44	19	54	23	66	29
		89	R26.016.089	1,98	36	18	44	22	53	27	66	34,5
		102	R26.016.102	1,72	34	20	45	26	53	31	66	40
		305	R26.016.305	0,54	33	61	41	76	49	91	66	122

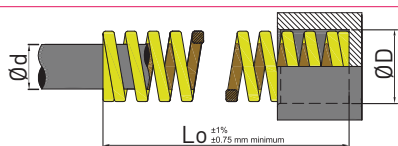

Diameters : 10 to 20mm
Rectangular wire



Hole Ø mm	Rod Ø mm	Free length mm	Reference	RATE (daN) required to deflect 1 mm	LOAD TABLE								
					S1 Total deflection recommended for long life (17% of Lo)		S2 Total deflection recommended for average life (20% of Lo)		S3 Maximum operating deflection (25% of Lo)		Total travel to solid		
					Load daN	Deflect. mm	Load daN	Deflect. mm	Load daN	Deflect. mm	Load daN	Deflect. mm	
D	d	Lo	C										
10	5	25	S36.010.025	3,27	13,7	4,2	16,4	5	20,3	6,2	29,5	8,7	
		32	S36.010.032	2,50	13,8	5,5	16,3	6,5	20	8	27	10,5	
		38	S36.010.038	2,12	13,8	6,5	15,2	7,5	20,1	9,5	27	13,2	
		44	S36.010.044	1,77	13,3	7,5	15,9	9	19,5	11	26,5	15	
		51	S36.010.051	1,53	13,3	8,7	15,3	10	19,9	13	26,5	17	
		64	S36.010.064	1,22	13,4	11	15,9	13	19,5	16	26,5	21,5	
		76	S36.010.076	1,01	13,1	13	15,2	15	19,2	19	26,5	26,5	
		305	S36.010.305	0,25	13	52	15,3	61	19	76	26	106	
12,5	6,3	25	S36.012.025	5,87	24,7	4,2	29,4	5	36,4	6,2	53	9	
		32	S36.012.032	4,43	24,4	5,5	28,8	6,5	35,4	8	48	10,8	
		38	S36.012.038	3,63	23,6	6,5	27,2	7,5	34,5	9,5	47	13	
		44	S36.012.044	3,06	23	7,5	27,5	9	33,7	11	47	15,5	
		51	S36.012.051	2,71	23,6	8,7	27,1	10	35,2	13	47	18	
		64	S36.012.064	2,17	23,9	11	28,2	13	34,7	16	47	22	
		76	S36.012.076	1,77	23	13	26,6	15	33,6	19	47	27	
		89	S36.012.089	1,51	22,7	15	27,2	18	33	22	50	33	
305	S36.012.305	0,42	21,8	52	25,6	61	31,9	76	47	112			
16	8	25	S36.016.025	12,6	53	4,2	63	5	78	6,2	113	9	
		32	S36.016.032	9,3	51	5,5	60	6,5	74	8	103	10,8	
		38	S36.016.038	7,5	49	6,5	56	7,5	71	9,5	98	13	
		44	S36.016.044	6,3	47	7,5	57	9	69	11	96	15	
		51	S36.016.051	5,5	48	8,7	55	10	72	13	96	18	
		64	S36.016.064	4,3	47	11	56	13	69	16	95	22	
		76	S36.016.076	3,52	46	13	53	15	67	19	94	26,5	
		89	S36.016.089	3,00	45	15	54	18	66	22	94	31,5	
102	S36.016.102	2,61	44	17	52	20	68	26	94	36,5			
305	S36.016.305	0,85	44	52	52	61	65	76	94	110			
20	10	25	S36.020.025	32,2	135	4,2	161	5	202	6,2	248	7,7	
		32	S36.020.032	24,2	133	5,5	157	6,5	194	8	237	9,8	
		38	S36.020.038	19,5	127	6,5	146	7,5	185	9,5	234	12	
		44	S36.020.044	16,3	122	7,5	147	9	179	11	228	14	
		51	S36.020.051	14,0	122	8,7	140	10	182	13	225	16	
		64	S36.020.064	10,9	120	11	142	13	174	16	225	21	
		76	S36.020.076	9,0	117	13	135	15	171	19	225	25	
		89	S36.020.089	7,6	114	15	137	18	167	22	225	30	
		102	S36.020.102	6,6	112	17	132	20	172	26	225	34	
		115	S36.020.115	5,8	116	20	133	23	168	29	220	38	
		127	S36.020.127	5,2	114	22	130	25	166	32	220	43	
		140	S36.020.140	4,7	113	24	132	28	165	35	221	47	
		152	S36.020.152	4,3	112	26	129	30	163	38	220	51	
305	S36.020.305	2,12	110	52	129	61	161	76	220	105			

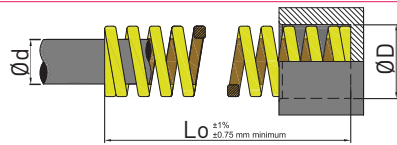

Diameters : 25 to 50mm
Rectangular wire



Hole Ø mm	Rod Ø mm	Free length mm	Reference	RATE (daN) required to deflect 1 mm	LOAD TABLE							
					S1 Total deflection recommended for long life (17% of Lo)		S2 Total deflection recommended for average life (20% of Lo)		S3 Maximum operating deflection (25% of Lo)		Total travel to solid	
					Load daN	Deflect. mm	Load daN	Deflect. mm	Load daN	Deflect. mm	Load daN	Deflect. mm
D	d	Lo	C	C								
25	12,5	32	S36.025.032	35,4	195	5,5	230	6,5	283	8	354	10
		38	S36.025.038	28,0	182	6,5	210	7,5	266	9,5	336	12
		44	S36.025.044	23,2	174	7,5	209	9	255	11	325	14
		51	S36.025.051	19,8	172	8,7	198	10	257	13	317	16
		64	S36.025.064	15,4	169	11	200	13	246	16	316	21
		76	S36.025.076	12,5	163	13	188	15	238	19	313	25
		89	S36.025.089	10,5	158	15	189	18	231	22	310	29
		102	S36.025.102	9,1	155	17	182	20	237	26	310	34
		115	S36.025.115	8,1	162	20	186	23	235	29	310	39
		127	S36.025.127	7,2	158	22	180	25	230	32	310	43
		140	S36.025.140	6,6	158	24	185	28	231	35	317	48
		152	S36.025.152	6,0	156	26	180	30	228	38	310	53
		178	S36.025.178	5,1	153	30	184	36	224	44	310	62
		203	S36.025.203	4,5	153	34	180	40	230	51	310	70
305	S36.025.305	2,96	154	52	181	61	225	76	310	108		
32	16	38	S36.032.038	48,9	318	6,5	367	7,5	465	9,5	558	11
		44	S36.032.044	40,5	304	7,5	365	9	446	11	547	13
		51	S36.032.051	34,6	301	8,7	346	10	450	13	535	15
		64	S36.032.064	26,7	294	11	347	13	427	16	535	20
		76	S36.032.076	21,6	281	13	324	15	410	19	525	24
		89	S36.032.089	18,2	273	15	328	18	400	22	525	29
		102	S36.032.102	15,6	265	17	312	20	406	26	520	33
		115	S36.032.115	13,6	272	20	313	23	394	29	500	36
		127	S36.032.127	12,2	268	22	305	25	390	32	500	41
		140	S36.032.140	11,2	269	24	314	28	392	35	526	47
		152	S36.032.152	10,1	263	26	303	30	384	38	500	50
		178	S36.032.178	8,6	258	30	310	36	378	44	500	59
		203	S36.032.203	7,5	255	34	308	40	383	51	500	68
		254	S36.032.254	6,0	258	43	306	51	384	64	500	85
305	S36.032.305	5,0	260	52	305	61	380	76	500	103		
40	20	51	S36.040.051	56,0	487	8,7	560	10	714	13	840	15
		64	S36.040.064	42,2	464	11	549	13	675	16	820	19
		76	S36.040.076	34,3	446	13	525	15	652	19	815	24
		89	S36.040.089	28,2	423	15	508	18	620	22	800	28
		102	S36.040.102	24,4	415	17	488	20	634	26	800	33
		115	S36.040.115	21,4	428	20	492	23	621	29	792	37
		127	S36.040.127	19,0	418	22	475	25	608	32	780	41
		140	S36.040.140	17,1	410	24	479	28	599	35	787	46
		152	S36.040.152	15,6	406	26	468	30	593	38	780	50
		178	S36.040.178	13,2	396	30	475	36	581	44	765	58
		203	S36.040.203	11,4	388	34	456	40	581	51	765	67
		254	S36.040.254	9,1	391	43	464	51	582	64	765	85
		305	S36.040.305	7,5	390	52	458	61	570	76	760	102
		50	25	64	S36.050.064	72,4	796	11	941	13	1158	16
76	S36.050.076			57,3	745	13	860	15	1089	19	1318	23
89	S36.050.089			47,4	711	15	853	18	1043	22	1280	27
102	S36.050.102			40,4	687	17	808	20	1050	26	1252	31
115	S36.050.115			35,3	706	20	812	23	1024	29	1235	35
127	S36.050.127			31,2	686	22	780	25	998	32	1217	39
140	S36.050.140			28,2	677	24	790	28	987	35	1241	44
152	S36.050.152			25,5	663	26	765	30	969	38	1200	47
178	S36.050.178			21,5	645	30	774	36	946	44	1200	56
203	S36.050.203			18,6	632	34	744	40	949	51	1190	64
254	S36.050.254			14,6	628	43	745	51	934	64	1170	80
305	S36.050.305			12,1	629	52	738	61	920	76	1170	97

1 daN = 1.0197 kg

Note: Need for internal guide(Lo ≥ 4xD)

Preloaded springs offer key benefits

Each spring is individually attached and pre-loaded to the desired length. When assembling the tool, there is no need to compress all of the springs. In the resting position, the springs are not preloaded by the retainer. This saves time and improves safety during assembly and maintenance operations.

D1	D2	D3	D4	L1	L2	L3	Reference
37	20	16,5	10	48	3	4	FH2
49	25	21,5	13,5	48	4	3	FH3
49	25	21,5	13,5	73	4	3	FH4



Assembly examples

- A** Preloaded spring with FH_x retainer and A17.xxx.xxx shoulder screw
- B** Preloaded spring with S65.010.xxx washer and A15.xxx.xxx locking grub screw
- C** Travel is restricted using an A15.xxx.xxx locking grub screw

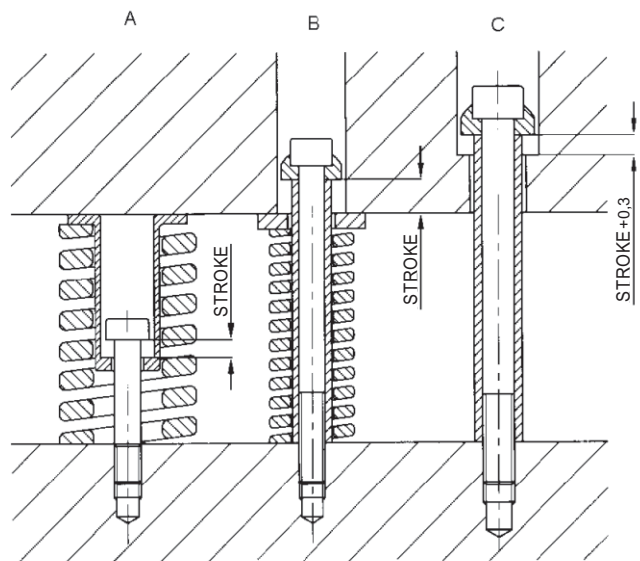
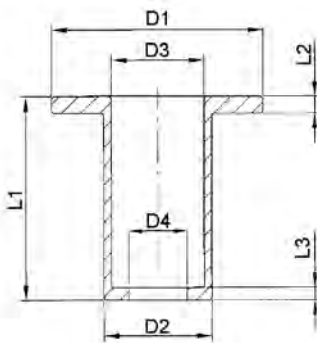

ELASTOMER RODS

S66
S67
S68
S69



Ordering example:

Solid 80 rod, Shore A, ØD=16 L=300

Please state: **S68.016.300**

Elastomer rods are available in two hardness qualities.

80 Shore A
Maximum travel: 35%
Compaction under compression: 5-7%

90 Shore A
Maximum travel: 30%
Compaction under compression 6-8%

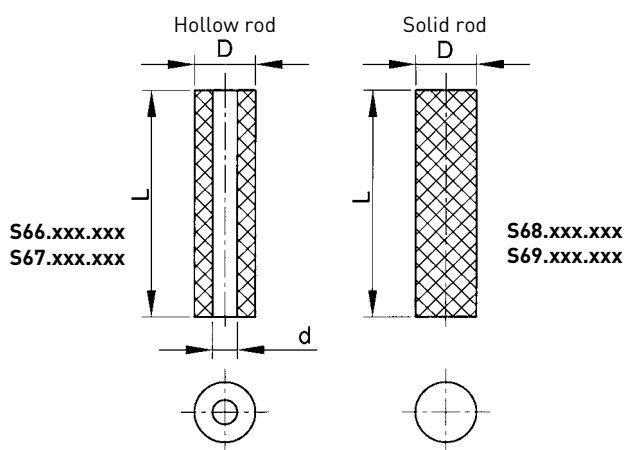

D	d	L	80 Shore A Reference Hollow rod	90 Shore A Reference Hollow rod
16	6,5	300	S66.016.300	S67.016.300
20	8,5	300	S66.020.300	S67.020.300
25	10,5	300	S66.025.300	S67.025.300
32	13,5	300	S66.032.300	S67.032.300
40	13,5	300	S66.040.300	S67.040.300
50	17	400	S66.050.400	S67.050.400
63	17	400	S66.063.400	S67.063.400
80	21	400	S66.080.400	S67.080.400
100	21	300	S66.100.300	S67.100.300
125	27	300	S66.125.300	S67.125.300

D	L	80 Shore A Reference Solid rod	90 Shore A Reference Solid rod
16	300	S68.016.300	S69.016.300
20	300	S68.020.300	S69.020.300
25	300	S68.025.300	S69.025.300
32	300	S68.032.300	S69.032.300
40	300	S68.040.300	S69.040.300
50	400	S68.050.400	S69.050.400
63	400	S68.063.400	S69.063.400
80	400	S68.080.400	S69.080.400
100	300	S68.100.300	S69.100.300
125	300	S68.125.300	S69.125.300

Processing	80 Shore A	90 Shore A
Sawing	+	+
Cutting	++	++
Drilling	0	+
Reaming	++	++
Lathe turning	0	+
Milling	+	++
Grinding	+	+
Tapping	-	-
++ Very good + Good 0 Satisfactory - Subject to reserv.		
When manufacturing special springs, the length L must not be exceeded		

Resistance	80 Shore A	90 Shore A
Lubricant	+	+
Grease	+	+
Alcohol	+	+
Thinner	+	+
Water	-	-
Ozone	+	+
Lye	-	-
Acids	-	-
+ Good - Subject to reservations		

To be mounted with guide shaft S60 or with shoulder screws A17



Ordering example:
Spring Ø D1=16 Lo=12

Please state
S50.016.012

Elastomer springs

Hardness: 70 Shore A
Max. compression: 40% of Lo
Max. permissible temperature: 80°C
D2: Footprint diameter when compressed to 40% of Lo

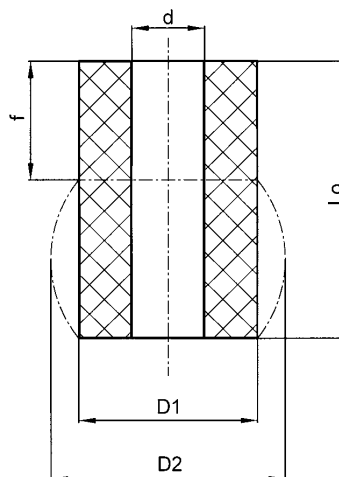

D1	d	D2 fmax	Lo	Reference
16	6,5	23	12	S50.016.012
16	6,5	23	16	S50.016.016
16	6,5	23	20	S50.016.020
16	6,5	23	25	S50.016.025
20	8,5	28	16	S50.020.016
20	8,5	28	20	S50.020.020
20	8,5	28	25	S50.020.025
20	8,5	28	32	S50.020.032
25	10,5	35	20	S50.025.020
25	10,5	35	25	S50.025.025
25	10,5	35	32	S50.025.032
25	10,5	35	40	S50.025.040
32	13,5	45	32	S50.032.032
32	13,5	45	40	S50.032.040
32	13,5	45	50	S50.032.050
32	13,5	45	63	S50.032.063
40	13,5	56	32	S50.040.032
40	13,5	56	40	S50.040.040
40	13,5	56	50	S50.040.050
40	13,5	56	63	S50.040.063
40	13,5	56	80	S50.040.080
50	17	70	32	S50.050.032
50	17	70	40	S50.050.040
50	17	70	50	S50.050.050
50	17	70	63	S50.050.063
50	17	70	80	S50.050.080
50	17	70	100	S50.050.100

D1	d	D2 fmax	Lo	Reference
63	17	89	32	S50.063.032
63	17	89	40	S50.063.040
63	17	89	50	S50.063.050
63	17	89	63	S50.063.063
63	17	89	80	S50.063.080
63	17	89	100	S50.063.100
63	17	89	125	S50.063.125
80	21	112	32	S50.080.032
80	21	112	40	S50.080.040
80	21	112	50	S50.080.050
80	21	112	63	S50.080.063
80	21	112	80	S50.080.080
80	21	112	100	S50.080.100
80	21	112	125	S50.080.125
100	21	140	32	S50.100.032
100	21	140	40	S50.100.040
100	21	140	50	S50.100.050
100	21	140	63	S50.100.063
100	21	140	80	S50.100.080
100	21	140	100	S50.100.100
100	21	140	125	S50.100.125
125	27	175	32	S50.125.032
125	27	175	40	S50.125.040
125	27	175	50	S50.125.050
125	27	175	63	S50.125.063
125	27	175	100	S50.125.100
125	27	175	125	S50.125.125
125	27	175	160	S50.125.160

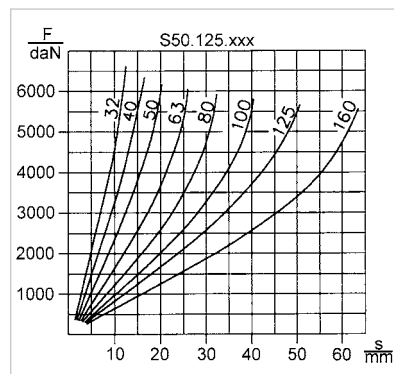
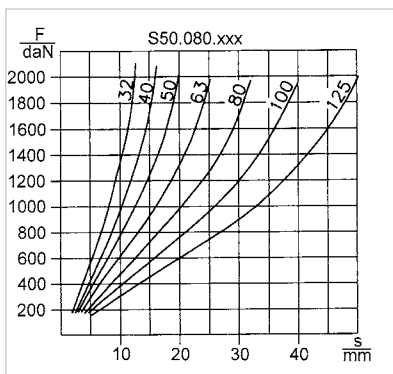
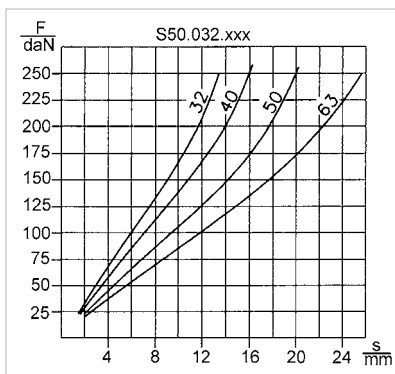
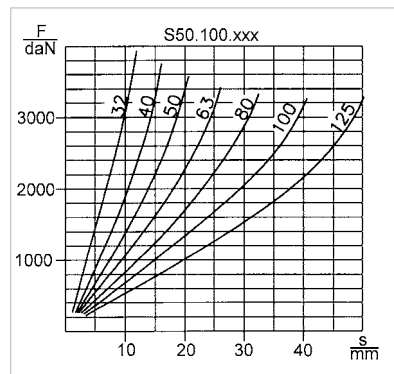
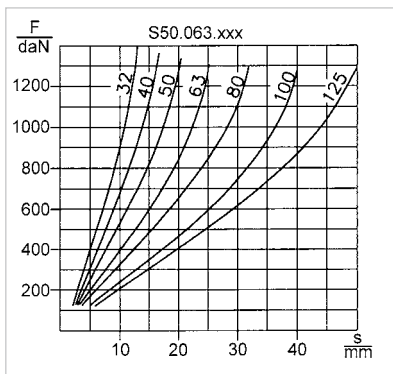
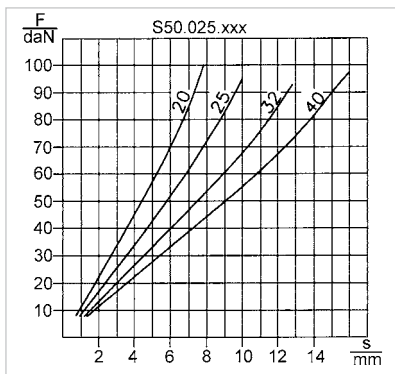
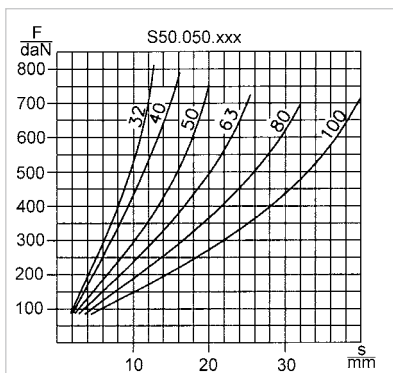
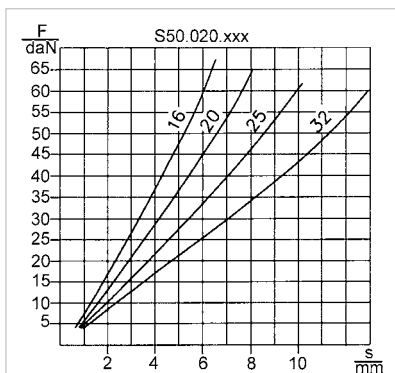
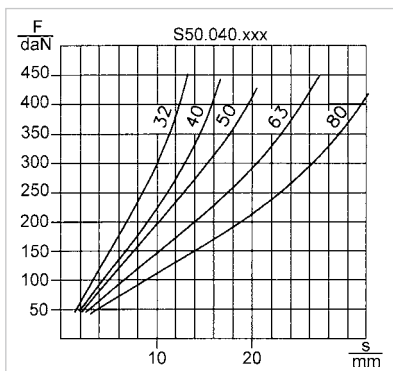
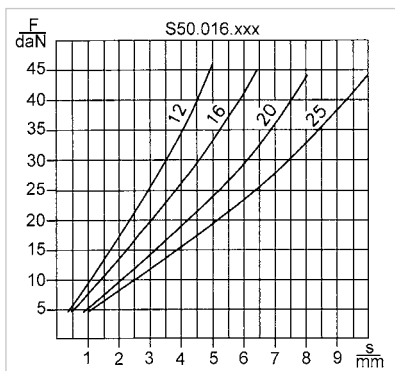

To be mounted with guide shaft S60 or with shoulder screws A17



Elastomer springs

Hardness: 90 Shore A
Max. compression: 30% of Lo
Max. permissible temperature: 80°C
D2: Footprint diameter when compressed to 30% of Lo

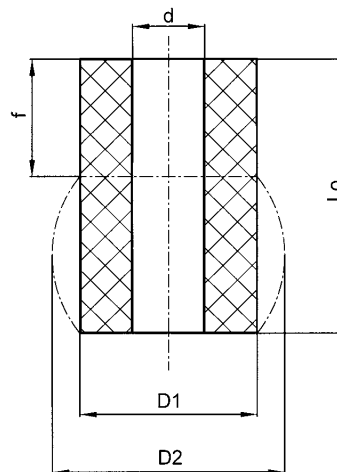

Ordering example

Spring Ø D1=16 Lo=12

Please state
S55.016.012

D1	d	D2 fmax	Lo	Reference
16	6,5	20	12	S55.016.012
16	6,5	20	16	S55.016.016
16	6,5	20	20	S55.016.020
16	6,5	20	25	S55.016.025
20	8,5	25	16	S55.020.016
20	8,5	25	20	S55.020.020
20	8,5	25	25	S55.020.025
20	8,5	25	32	S55.020.032
25	10,5	30	20	S55.025.020
25	10,5	30	25	S55.025.025
25	10,5	30	32	S55.025.032
25	10,5	30	40	S55.025.040
32	13,5	39	32	S55.032.032
32	13,5	39	40	S55.032.040
32	13,5	39	50	S55.032.050
32	13,5	39	63	S55.032.063
40	13,5	48	32	S55.040.032
40	13,5	48	40	S55.040.040
40	13,5	48	50	S55.040.050
40	13,5	48	63	S55.040.063
40	13,5	48	80	S55.040.080
50	17	60	32	S55.050.032
50	17	60	40	S55.050.040
50	17	60	50	S55.050.050
50	17	60	63	S55.050.063
50	17	60	80	S55.050.080
50	17	60	100	S55.050.100

D1	d	D2 fmax	Lo	Reference
63	17	76	32	S55.063.032
63	17	76	40	S55.063.040
63	17	76	50	S55.063.050
63	17	76	63	S55.063.063
63	17	76	80	S55.063.080
63	17	76	100	S55.063.100
63	17	76	125	S55.063.125
80	21	96	32	S55.080.032
80	21	96	40	S55.080.040
80	21	96	50	S55.080.050
80	21	96	63	S55.080.063
80	21	96	80	S55.080.080
80	21	96	100	S55.080.100
80	21	96	125	S55.080.125
100	21	120	32	S55.100.032
100	21	120	40	S55.100.040
100	21	120	50	S55.100.050
100	21	120	63	S55.100.063
100	21	120	80	S55.100.080
100	21	120	100	S55.100.100
100	21	120	125	S55.100.125
125	27	150	32	S55.125.032
125	27	150	40	S55.125.040
125	27	150	50	S55.125.050
125	27	150	63	S55.125.063
125	27	150	80	S55.125.080
125	27	150	100	S55.125.100
125	27	150	125	S55.125.125
125	27	150	160	S55.125.160

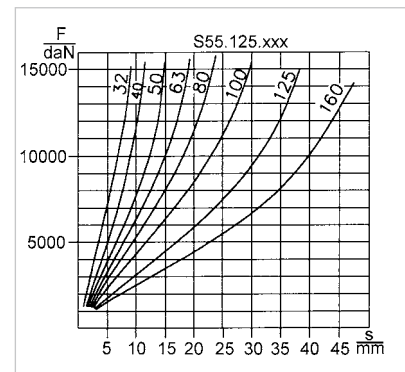
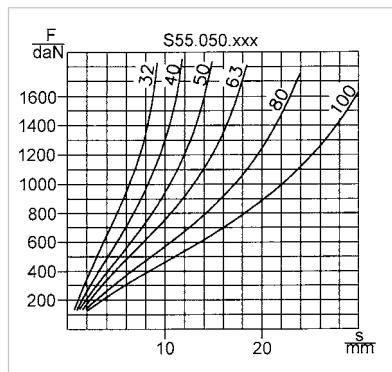
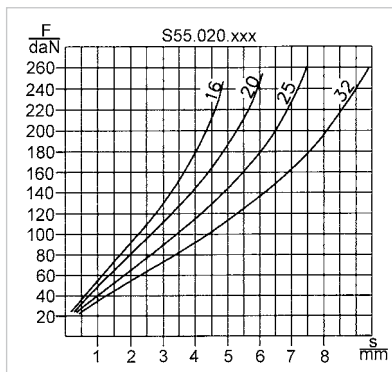
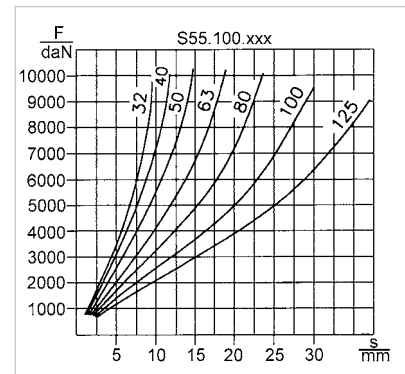
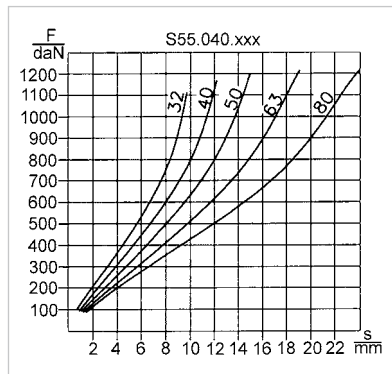
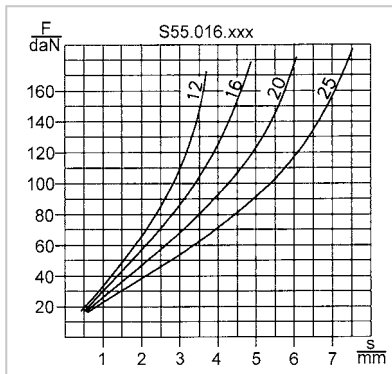
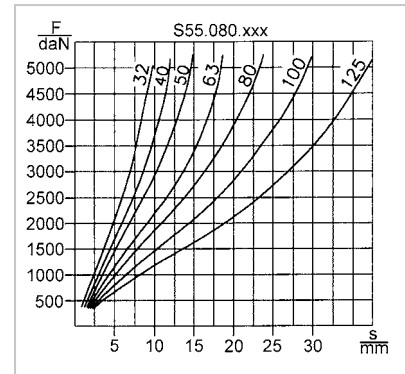
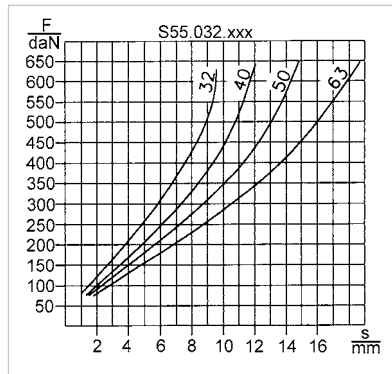
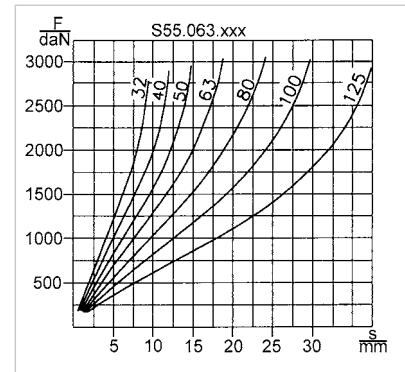
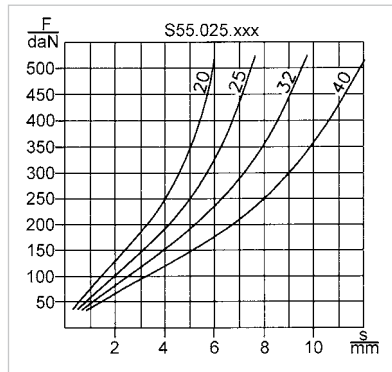

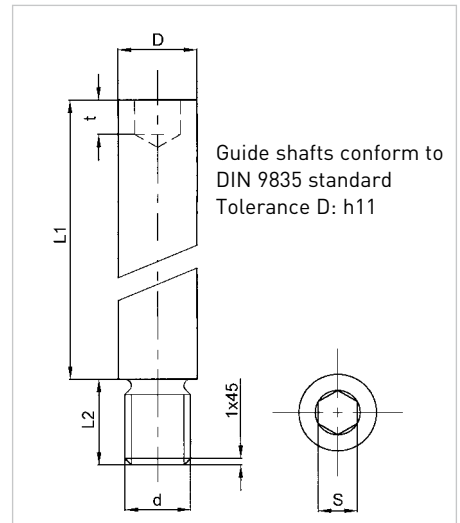
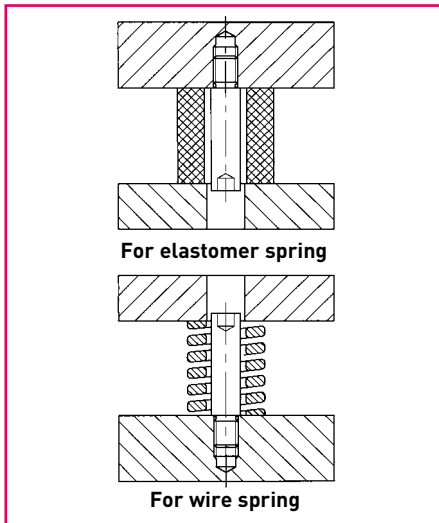

Ordering example
Ø 6 mm guide shaft
Length: 20 mm
Please state : **S60.006.020**

D	6	8	10	13	16	20	25	
d	M4	M6	M8	M10	M12	M16	M20	
L2	6	9	15	15	18	25	30	
s	3	4	5	6	8	10	14	
t	2,5	3	4	5	6	8	10	
L1	20	S60.006.020	S60.008.020	S60.010.020				
	25	S60.006.025	S60.008.025	S60.010.025				
	32	S60.006.032	S60.008.032	S60.010.032	S60.013.032	S60.016.032	S60.020.032	S60.025.032
	40		S60.008.040	S60.010.040	S60.013.040	S60.016.040	S60.020.040	S60.025.040
	50		S60.008.050	S60.010.050	S60.013.050	S60.016.050	S60.020.050	S60.025.050
	63			S60.010.063	S60.013.063	S60.016.063	S60.020.063	S60.025.063
	80				S60.013.080	S60.016.080	S60.020.080	S60.025.080
	95				S60.013.095	S60.016.095	S60.020.095	S60.025.095
	118					S60.016.118	S60.020.118	S60.025.118
	140					S60.016.140	S60.020.140	S60.025.140
	180							S60.025.180

Conform to : DIN 9835
Material : Brass

Ordering example
Ø20 washer
Please state: **S65.010.020**

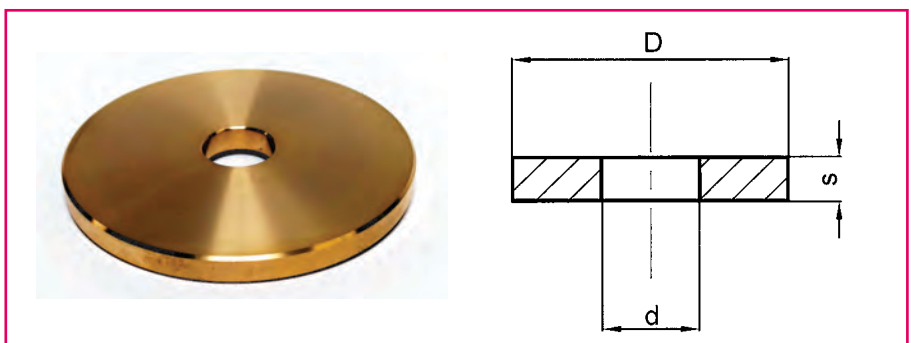

D	20	25	30	40	50	60	80	100	120	150
d	6,5	8,5	10,5	13,5	13,5	16,5	16,5	20,5	20,5	26
9	4	4	5	5	5	6	6	8	8	8
Reference	S65.010.020	S65.010.025	S65.010.030	S65.010.040	S65.010.050	S65.010.060	S65.010.080	S65.010.100	S65.010.120	S65.010.150

Preloaded springs offer key benefits

Each spring is individually attached and pre-loaded to the desired length.
When assembling the tool, there is no need to compress all of the springs.
In the resting position, the springs are not preloaded by the retainer.
This saves time and improves safety during assembly and maintenance operations.

Assembly examples

- A** Preloaded spring with S65.xxx.xxx washer and A15.xxx.xxx locking grub screw
- B** Restriction of travel via one A15.xxx.xxx locking grub screw

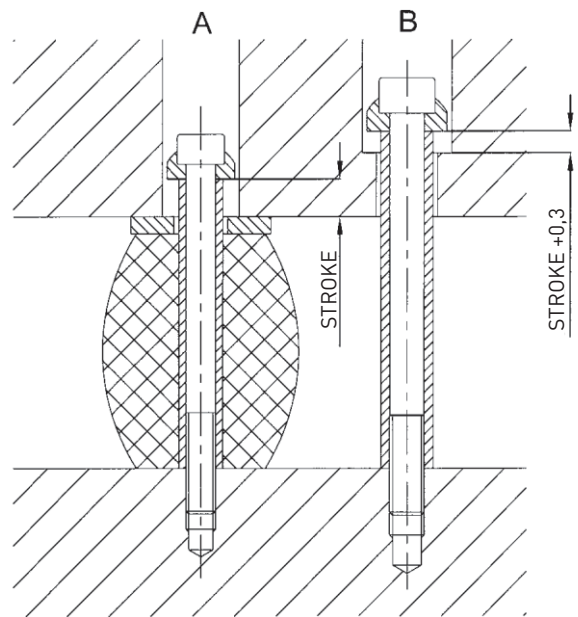

Footprint

Elastomer springs are incompressible. Their deformation under load causes them to swell. This means that the swelling percentage is equal to the compression percentage. Therefore, it is essential to monitor the swelling curve in order to determine and define the locations and safety zones.

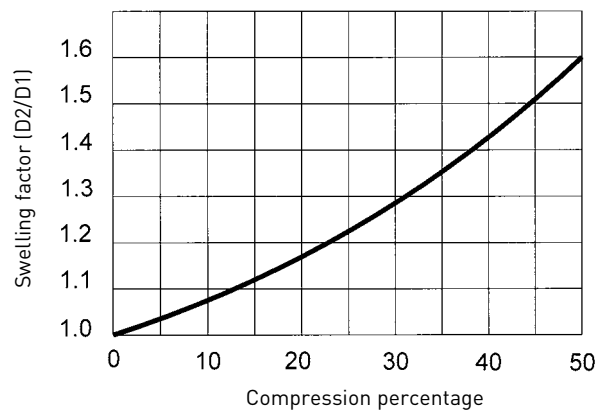



NOTES

A large rectangular area with a thin black border, containing 20 horizontal dotted lines for writing notes.

SUMMARY

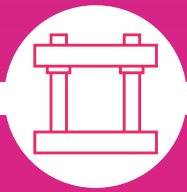

Die sets

Die sets 3

Custom machining / machine capacities 25

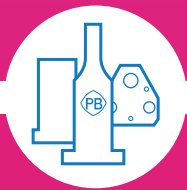

Punches and dies

Punches
Dies
Retainers
Accessories

Punches30

Dies56

Punch retainers 69

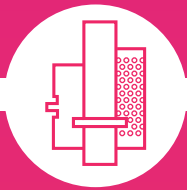

Guiding elements

Pillar
Bushes
Ball cages
Accessories

MDL Blueline range to DIN standard92

MDL range to ISO standard111

MDL Porter Besson range to AFNOR / CNOMO standard 145

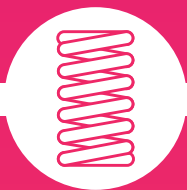

Springs

Compressions springs
Gas springs
Elastomer springs
Accessories

Compressions springs176

Elastomer springs192

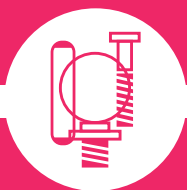

Accessories

Screws 202

Lifting211

Others 215



Accessories



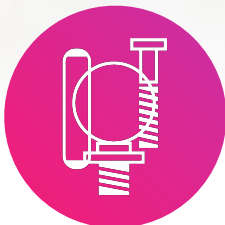

New products



Drill bushes flanged A172

Discover our range of flanged drill bushes A172 according to DIN 172 standard. Available from diameter 0.9mm to 63mm. The drill bushes are used to guide drill bits or shaft in mechanisms requiring precise alignment.

[To the product page](#)

[To the catalog page](#)



Drill bushes A179

Discover our range of drill bushes A179 according to DIN 179 standard. Available from diameter 0.9mm to 63mm. The drill bushes are used to guide drill bits or shaft in mechanisms requiring precise alignment.

[To the product page](#)

[To the catalog page](#)











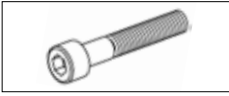
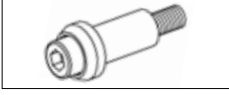
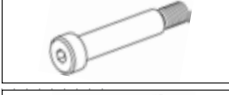

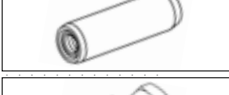
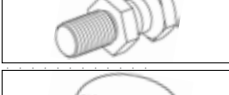
Centring units PDC

The centring units PDC are used to increase the precision of repetitive centring in moulds, press tooling and some machining fixtures. It ensures very precise recentring at the end of the stroke. The male and female parts are sold together.

[To the product page](#)

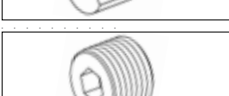
[To the catalog page](#)

■ Socket head cap screws	A05		206
■ Stripper bolts	A15		207
■ Shoulder screws	A17		208
■ Dowel pins	A20		209
■ Dowel pins	A25		210
■ Lifting lugs	A30.010		211
■ Collar eye bolts	A30.012		211
■ Swivel lifting rings	A30.013		212
■ Lifter studs	A30.015		212
■ Location bolts	A30.02		213
■ Lifting bolt	BRM.V1		213
■ Compression pads	A50		214
■ Threaded plugs	A32		214
■ Drill bushes flanged	A172		215
■ Drill bushes	A179		217
■ Centring units	PDC		219
■ Band Guide and Lifter kit			221

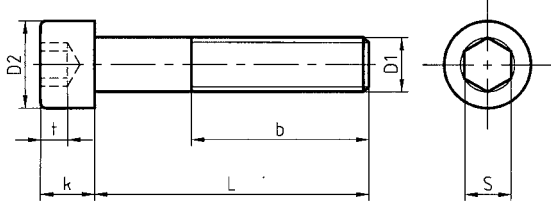

Conforms to : NF EN ISO 4762
Material : Steel
Strength : Category 12.9
: Mini 1200 N/mm²

Ordering example

M8 L=50 hexagon socket head cap screw

Please state: Réf. A05.008.050

D1	M3	M4	M5	M6	M8	M10	M12	M16	M20
D2	5.5	7	8.5	10	13	16	18	24	30
b	18	20	22	24	28	32	36	44	52
k	3	4	5	6	8	10	12	16	20
t min.	1,3	2	2,5	3	4	5	6	8	10
S	2,5	3	4	5	6	8	10	14	17
L	Reference								
8	A05.003.008	A05.004.008							
10	A05.003.010	A05.004.010	A05.005.010						
12	A05.003.012	A05.004.012	A05.005.012	A05.006.012					
16	A05.003.016	A05.004.016	A05.005.016	A05.006.016	A05.008.016				
20	A05.003.020	A05.004.020	A05.005.020	A05.006.020	A05.008.020	A05.010.020			
25	A05.003.025	A05.004.025	A05.005.025	A05.006.025	A05.008.025	A05.010.025	A05.012.025		
30	A05.003.030	A05.004.030	A05.005.030	A05.006.030	A05.008.030	A05.010.030	A05.012.030		
35		A05.004.035	A05.005.035	A05.006.035	A05.008.035	A05.010.035	A05.012.035	A05.016.035	
40		A05.004.040	A05.005.040	A05.006.040	A05.008.040	A05.010.040	A05.012.040	A05.016.040	A05.020.040
45		A05.004.045	A05.005.045	A05.006.045	A05.008.045	A05.010.045	A05.012.045	A05.016.045	A05.020.045
50		A05.004.050	A05.005.050	A05.006.050	A05.008.050	A05.010.050	A05.012.050	A05.016.050	A05.020.050
55			A05.005.055	A05.006.055	A05.008.055	A05.010.055	A05.012.055	A05.016.055	A05.020.055
60			A05.005.060	A05.006.060	A05.008.060	A05.010.060	A05.012.060	A05.016.060	A05.020.060
65				A05.006.065	A05.008.065	A05.010.065	A05.012.065	A05.016.065	A05.020.065
70				A05.006.070	A05.008.070	A05.010.070	A05.012.070	A05.016.070	A05.020.070
80				A05.006.080	A05.008.080	A05.010.080	A05.012.080	A05.016.080	A05.020.080
90				A05.006.090	A05.008.090	A05.010.090	A05.012.090	A05.016.090	A05.020.090
100					A05.008.100	A05.010.100	A05.012.100	A05.016.100	A05.020.100
120					A05.008.120	A05.010.120	A05.012.120	A05.016.120	A05.020.120
130					A05.008.130	A05.010.130	A05.012.130	A05.016.130	A05.020.130
140					A05.008.140	A05.010.140	A05.012.140	A05.016.140	A05.020.140
150					A05.008.150	A05.010.150	A05.012.150	A05.016.150	A05.020.150
160					A05.008.160	A05.010.160	A05.012.160	A05.016.160	A05.020.160
180					A05.008.180	A05.010.180	A05.012.180	A05.016.180	A05.020.180
200						A05.010.200	A05.012.200	A05.016.200	A05.020.200

A15.XXX.XXX

WASHER :

Heat treated, tempered and burnished steel
Strength: 100 kg/mm²

TUBE :

Heat treated, tempered and ground steel
Ext. tolerance = h7
Longitudinal tolerance +0.1
-0

SCREW : Category 12.9

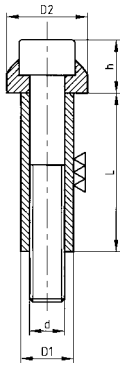

Assembly examples

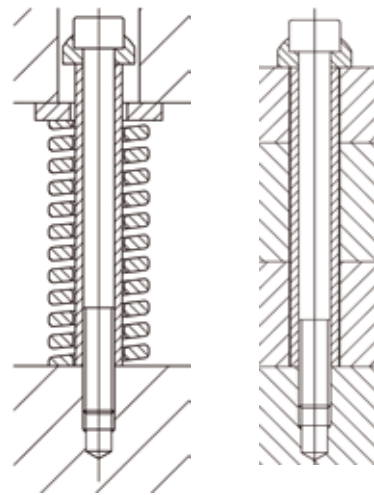

Ordering example

Shoulder screw - diameter: 15, length: 50

Please state: Ref. **A15.015.050**

D1	10	12.5	15	17.5	23
d	M6	M8	M10	M12	M16
D2	15	19	23	27	34
h	10	13	15	18	24
Maximum torque					
N/m	13	32	65	120	290
Maximum load					
daN	140	400	1000	1600	2400
Length	Reference				
20	A15.010.020				
25	A15.010.025				
30	A15.010.030	A15.012.030	A15.015.030		
35	A15.010.035	A15.012.035	A15.015.035		
40	A15.010.040	A15.012.040	A15.015.040	A15.017.040	
45	A15.010.045	A15.012.045	A15.015.045	A15.017.045	
50	A15.010.050	A15.012.050	A15.015.050	A15.017.050	A15.023.050
55	A15.010.055	A15.012.055	A15.015.055	A15.017.055	
60	A15.010.060	A15.012.060	A15.015.060	A15.017.060	A15.023.060
70		A15.012.070	A15.015.070	A15.017.070	A15.023.070
80		A15.012.080	A15.015.080	A15.017.080	A15.023.080
90			A15.015.090	A15.017.090	A15.023.090
100			A15.015.100	A15.017.100	A15.023.100
110				A15.017.110	A15.023.110
120				A15.017.120	A15.023.120

Material : Heat treated steel
Strength : 1200 N/mm²

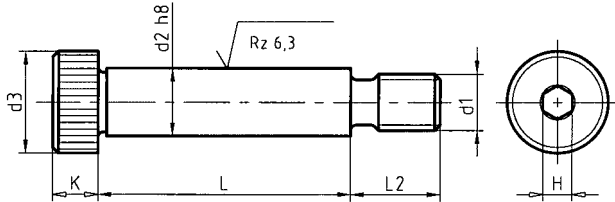

Assembly examples

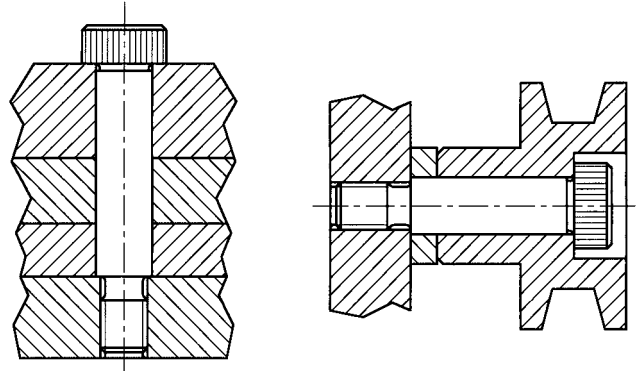

Ordering example

Shoulder screw - diameter: 10, length: 40

Please state: Ref. **A17.010.040**

d ₂	6	8	10	12	16	20	24
d ₁	M5	M6	M8	M10	M12	M16	M20
d ₃	10	13	16	18	24	30	36
K	4.5	5.5	7	8	10	14	16
L ₂	9.5	11	13	16	18	22	27
H	3	4	5	6	8	10	12
L ₀ :+0.1	Reference						
10	A17.006.010						
12	A17.006.012	A17.008.012					
16	A17.006.016	A17.008.016	A17.010.016	A17.012.016			
20	A17.006.020	A17.008.020	A17.010.020	A17.012.020			
25	A17.006.025	A17.008.025	A17.010.025	A17.012.025			
30	A17.006.030	A17.008.030	A17.010.030	A17.012.030	A17.016.030		
35	A17.006.035	A17.008.035	A17.010.035	A17.012.035	A17.016.035		
40	A17.006.040	A17.008.040	A17.010.040	A17.012.040	A17.016.040	A17.020.040	
45	A17.006.045	A17.008.045	A17.010.045	A17.012.045	A17.016.045	A17.020.045	
50	A17.006.050	A17.008.050	A17.010.050	A17.012.050	A17.016.050	A17.020.050	A17.024.050
55		A17.008.055	A17.010.055	A17.012.055	A17.016.055	A17.020.055	A17.024.055
60		A17.008.060	A17.010.060	A17.012.060	A17.016.060	A17.020.060	A17.024.060
65		A17.008.065	A17.010.065	A17.012.065	A17.016.065	A17.020.065	A17.024.065
70		A17.008.070	A17.010.070	A17.012.070	A17.016.070	A17.020.070	A17.024.070
80			A17.010.080	A17.012.080	A17.016.080	A17.020.080	A17.024.080
90				A17.012.090	A17.016.090	A17.020.090	A17.024.090
100				A17.012.100	A17.016.100	A17.020.100	A17.024.100
120					A17.016.120	A17.020.120	A17.024.120

Conforms to : DIN 6325 - AFNOR 27-475
Material : Tool steel
Hardness : 60 ± 2 HRc
Tolerance : m6

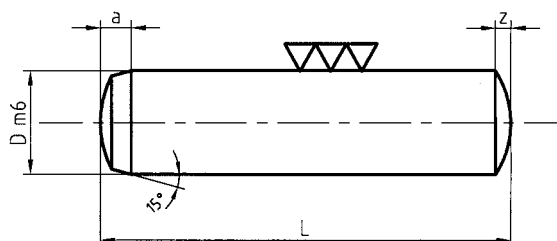

Ordering example

Dowel pin: D=8 L=50

Please state :

Réf. **A20.008.050**

D	3	4	5	6	8	10	12	16	20
a	1,1	1,4	1,7	2,1	2,6	3	3,8	4,7	6
z	0,45	0,6	0,75	0,9	1,2	1,5	1,8	2,5	3
Length	Reference								
10	A20.003.010	A20.004.010	A20.005.010	A20.006.010					
12	A20.003.012	A20.004.012	A20.005.012	A20.006.012					
16	A20.003.016	A20.004.016	A20.005.016	A20.006.016					
18	A20.003.018	A20.004.018	A20.005.018	A20.006.018	A20.008.018				
20	A20.003.020	A20.004.020	A20.005.020	A20.006.020	A20.008.020				
24	A20.003.024	A20.004.024	A20.005.024	A20.006.024	A20.008.024	A20.010.024			
28	A20.003.028	A20.004.028	A20.005.028	A20.006.028	A20.008.028	A20.010.028			
32	A20.003.032	A20.004.032	A20.005.032	A20.006.032	A20.008.032	A20.010.032			
36		A20.004.036	A20.005.036	A20.006.036	A20.008.036	A20.010.036	A20.012.036		
40		A20.004.040	A20.005.040	A20.006.040	A20.008.040	A20.010.040	A20.012.040		
45			A20.005.045	A20.006.045	A20.008.045	A20.010.045	A20.012.045		
50			A20.005.050	A20.006.050	A20.008.050	A20.010.050	A20.012.050	A20.016.050	A20.020.050
55				A20.006.055	A20.008.055	A20.010.055	A20.012.055		
60				A20.006.060	A20.008.060	A20.010.060	A20.012.060	A20.016.060	A20.020.060
70					A20.008.070	A20.010.070	A20.012.070		
80					A20.008.080	A20.010.080	A20.012.080	A20.016.080	A20.020.080
90						A20.010.090	A20.012.090	A20.016.090	A20.020.090
100						A20.010.100	A20.012.100	A20.016.100	A20.020.100
120						A20.010.120	A20.012.120	A20.016.120	A20.020.120

Conforms to : DIN 7979 - AFNOR 27-475
 Material : Tool steel
 Hardness : 60 ± 2 HRc
 Tolerance : m6

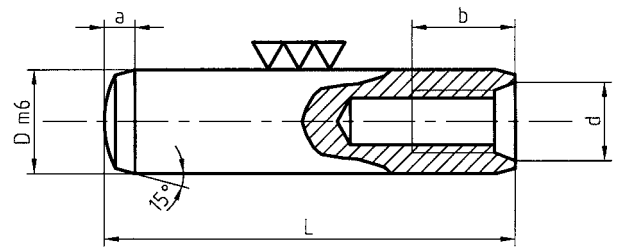

Ordering example

Dowel pin: D=8 L=50

Please state : Réf. **A25.008.050**

D	6	8	10	12	16	20
d	M4	M5	M6	M6	M8	M10
a	2,1	2,6	3,0	3,8	4,6	6,0
b	6	8	10	12	16	18
Length	Reference					
20	A25.006.020	A25.008.020	A25.010.020			
32	A25.006.032	A25.008.032	A25.010.032	A25.012.032		
40	A25.006.040	A25.008.040	A25.010.040	A25.012.040	A25.016.040	A25.020.040
50	A25.006.050	A25.008.050	A25.010.050	A25.012.050	A25.016.050	A25.020.050
60		A25.008.060	A25.010.060	A25.012.060	A25.016.060	A25.020.060
70		A25.008.070	A25.010.070	A25.012.070	A25.016.070	A25.020.070
80			A25.010.080	A25.012.080	A25.016.080	A25.020.080
100				A25.012.100	A25.016.100	A25.020.100
120					A25.016.120	A25.020.120

Material : C45 / 1.0503

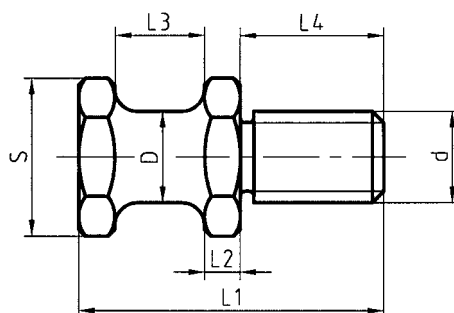

Ordering example:

Lifting lug with maximum load = 1500 daN
Please state: Réf. A30.010.030

D	Permis - sible load daN	d	L1	L2	L3	L4	S on flat	Reference
16	250	M16	58	5,5	20	28	24	A30.010.016
20	500	M20	68	8	20	32	30	A30.010.020
25	1000	M24	78	8	25	38	36	A30.010.024
32	1500	M30	95	10	32	45	41	A30.010.030
40	2500	M36	118	12	40	56	50	A30.010.036

Conforms to : DIN 580
Material : Hot-forged, deburred C15 steel

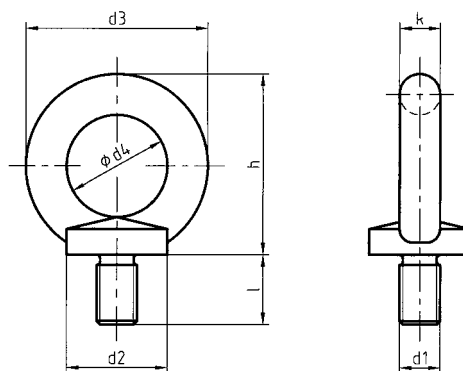

Ordering example

12 diameter collar eye bolt

Please state: Réf. A30.012.012

d1	Permis - sible load daN	d2	d3	d4	l	h	k	Reference
M8	140	20	36	20	13	36	8	A30.012.008
M10	230	25	45	25	17	45	10	A30.012.010
M12	340	30	54	30	20,5	53	12	A30.012.012
M16	700	35	63	35	27	62	14	A30.012.016
M20	1200	40	72	40	30	71	16	A30.012.020
M24	1800	50	90	50	36	90	20	A30.012.024
M36	5100	75	126	70	54	128	28	A30.012.036
M42	7000	80	144	80	63	147	32	A30.012.042

- High-strength suspension ring tested in accordance with DIN 5688-8
- Can be loaded in every direction - safety factor 4
- Can swivel under load
- Simple assembly with just a tapped hole
- Suitable for through holes
- Attractive and practical design
- Surface treatment: Red polymerised powder coating or electro-galvanised

Ordering example

16 diameter swivel lifting ring

Please state : Réf. A30.013.016

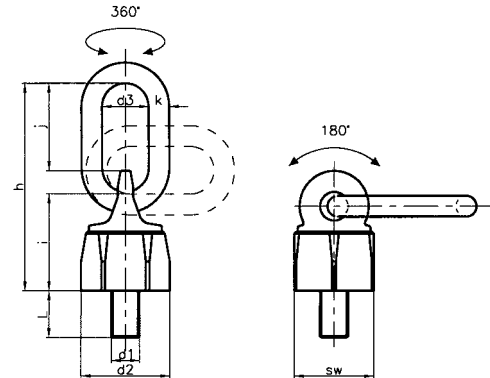

d1	Permissible load Tonnes	d2	d3	h	i	j	k	L	SW	Reference
M12	0,6	42	35	105	45	51	10	21	36	A30.013.012
M16	1,3	48	35	114	54	49	10	30	41	A30.013.016
M20	2,0	64	35	135	65	56	13	33	55	A30.013.020
M24	3,5	81	40	172	87	68	18	40	70	A30.013.024
M30	5,5	99	50	220	105	93	22	50	85	A30.013.030

Material : C45 / 1.0503

Ordering example

Lifter studs with maximum load = 2000 daN

Please state: Réf. A30.015.016

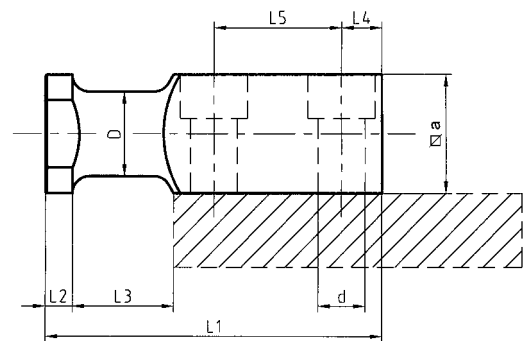

D	Permissible load daN	d for screw	Screw reference	L1	L2	L3	L4	L5	a	Reference
16	320	M8x30	A05.008.030	80	6	20	10	34	20	A30.015.008
20	630	M10x35	A05.010.035	90	8	25	10	37	25	A30.015.010
25	1250	M12x40	A05.012.040	100	8	30	12	38	35	A30.015.012
32	2000	M16x55	A05.016.055	120	10	32	16	46	40	A30.015.016
40	3200	M20x70	A05.020.070	140	10	40	18	54	50	A30.015.020

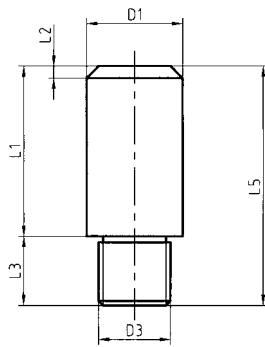

SHAPE A

Material 1.0503 / XC48

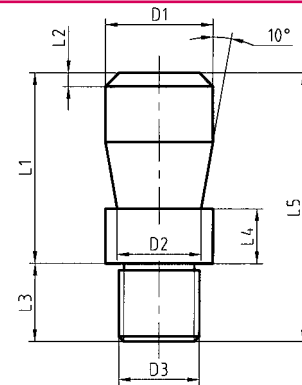

SHAPE B

Material 1.0503 / XC48

D1	D2	D3	L1	L2	L3	L4	L5	Shape A Reference	Shape B Reference
20	15	M16x1,5	40	3	18	12	58	A30.020.010	
25	20	M16x1,5	45	4	23	16	68	A30.020.020	A30.021.020
25	20	M20x1,5	45	4	23	16	68	A30.020.030	
32	25	M20x1,5	56	4	23	16	79	A30.020.040	
32	25	M24x1,5	56	4	23	16	79	A30.020.050	
40	32	M24x1,5	70	5	23	26	93	A30.020.060	A30.021.040
40	32	M30x2	70	5	23	26	93	A30.020.070	A30.021.060
50	42	M30x2	80	6	28	26	108	A30.020.080	A30.021.080

Conforms to : Standard NFE 63-132
Material : According to AFNOR
(French Association for Standardisation)
specification
NB. MABEC coding of components

Ordering example

Ø50 lifting bolt

Please state:

Réf. **BRM.050.V1**

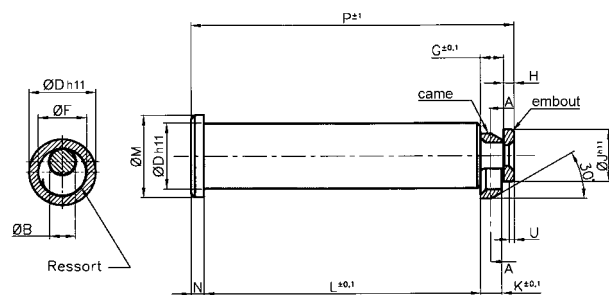

Dimensions without tolerances: ±0.25

Lifting capacity	ØD	ØB	ØF	G	H	ØJ	K	L	ØM	N	P	U	MABEC ref.	Order ref. no.
6 000 kg	32	12	22	11	5	25	10	132	40±0,8	6	154	2,5	P 953 254 770	BRM.032.V1
9 000 kg	40	16	28	13,75	6	32	12,5	170	50±0,8	8	197,75	3	P 953 255 870	BRM.040.V1
14 000 kg	50	20	36	17,60	8	40	16	212	63±1	10	247,60	4	P 953 256 670	BRM.050.V1
22 500 kg	63	25	45	22	10	50	20	265	80±1	12	309	5	P 953 257 470	BRM.063.V1

Material : Elastomer
Hardness : 90 Shore A

Ordering example

Ø 6 mm compression pad

Please state: Réf. A50.006.000

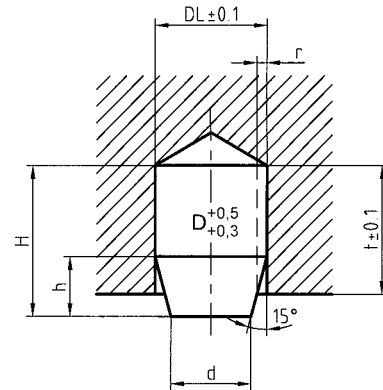

H	h	d	r	DL	t	P maxi (daN)	Reference
9,5	4,5	3,6	-	6	8	10	A50.006.000
15,5	7,5	6	1	10	13	45	A50.010.000
25	12	9,5	1,5	16	21	150	A50.016.000
25	10	18	2	24	21	300	A50.024.000
35	19	20	2,5	30	30	300	A50.030.000
32	14	24	3	32	26	1200	A50.032.000
40	16	30	3	39,5	34	2500	A50.040.000

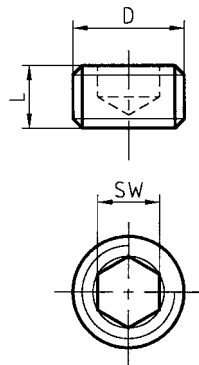

Application example

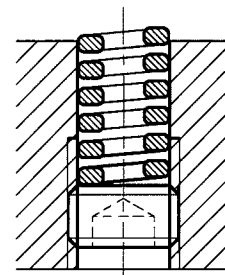

D	L	SW	Reference
M12x1,5	10	6	A32.012.010
M14x1,5	10	6	A32.014.010
M16x1,5	10	8	A32.016.010
M18x1,5	10	10	A32.018.010
M20x1,5	12	10	A32.020.012
M22x1,5	12	12	A32.022.012
M24x1,5	12	14	A32.024.012
M27x1,5	12	14	A32.027.012

Material : 16CrNi4 – Case hardened

Hardness : 60 – 62 Hrc

Standard : DIN 172

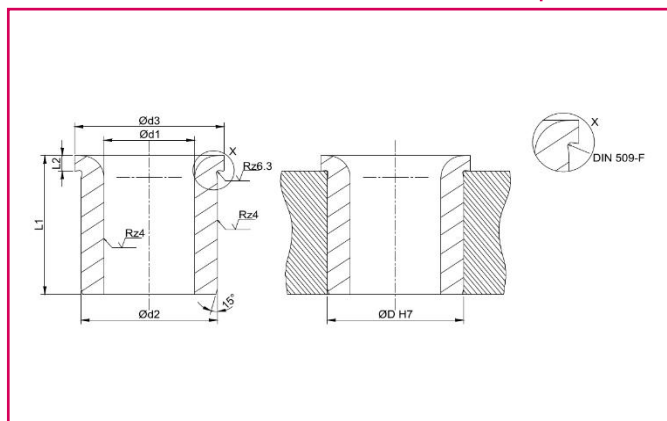

Ordering example

Drill bushes flanged Ø 6 mm length 10mm

Please state : Ref . A172.0600.010

D1 F7	Gradation	L1	D2 n6	D3	Positioning bore	References
0,9-1	0,1	6	3	6 mm	3 mm	A172.0XXX.006
		9	3	6 mm	3 mm	A172.0XXX.009
1,1-1,8	0,1	6	4	7 mm	4 mm	A172.0XXX.006
		9	4	7 mm	4 mm	A172.0XXX.009
1,9-2,6	0,1-0,25	6	5	8 mm	5 mm	A172.0XXX.006
		9	5	8 mm	5 mm	A172.0XXX.009
2,7-3,3	0,1-0,25	8	6	7 mm	6 mm	A172.0XXX.008
		12	6	7 mm	6 mm	A172.0XXX.012
		16	6	7 mm	6 mm	A172.0XXX.016
3,4-4	0,1-0,25	8	7	10 mm	7 mm	A172.0XXX.008
		12	7	10 mm	7 mm	A172.0XXX.012
		16	7	10 mm	7 mm	A172.0XXX.016
4,1-5	0,1-0,25	8	8	11 mm	8 mm	A172.0XXX.008
		12	8	11 mm	8 mm	A172.0XXX.012
		16	8	11 mm	8 mm	A172.0XXX.016
5,1-6	0,1-0,25	10	10	13 mm	10 mm	A172.0XXX.010
		16	10	13 mm	10 mm	A172.0XXX.016
		20	10	13 mm	10 mm	A172.0XXX.020
6,1-8	0,1-0,25	10	12	15 mm	12 mm	A172.0XXX.010
		16	12	15 mm	12 mm	A172.0XXX.016
		20	12	15 mm	12 mm	A172.0XXX.020
8,1-10	0,1-0,25	12	15	18 mm	15 mm	A172.0XXX.012
		20	15	18 mm	15 mm	A172.0XXX.020
		25	15	18 mm	15 mm	A172.0XXX.025
10,1-12	0,1-0,25	12	18	22 mm	18 mm	A172.0XXX.012
		20	18	22 mm	18 mm	A172.0XXX.020
		25	18	22 mm	18 mm	A172.0XXX.025

To the complete list of reference

D1 F7	Gradation	L1	D2 n6	D3	Positioning bore	References
12,1-15	0,25	16	22	26 mm	22 mm	A172.0XXX.016
		28	22	26 mm	22 mm	A172.0XXX.028
		36	22	26 mm	22 mm	A172.0XXX.036
15,25-18	0,25	16	26	30 mm	26 mm	A172.0XXX.016
		28	26	30 mm	26 mm	A172.0XXX.028
		36	26	30 mm	26 mm	A172.0XXX.036
18,25-22	0,25	20	30	34 mm	30 mm	A172.0XXX.020
		36	30	34 mm	30 mm	A172.0XXX.036
		45	30	34 mm	30 mm	A172.0XXX.045
22,25-26	0,25	20	35	39 mm	35 mm	A172.0XXX.020
		36	35	39 mm	35 mm	A172.0XXX.036
		45	35	39 mm	35 mm	A172.0XXX.045
26,25-30	0,25	20	42	46 mm	42 mm	A172.0XXX.020
		25	42	46 mm	42 mm	A172.0XXX.025
		36	42	46 mm	42 mm	A172.0XXX.036
		45	42	46 mm	42 mm	A172.0XXX.045
		56	42	46 mm	42 mm	A172.0XXX.056
30,25-35	0,25	25	48	52 mm	48 mm	A172.0XXX.025
		45	48	52 mm	48 mm	A172.0XXX.045
		56	48	52 mm	48 mm	A172.0XXX.056
35,5-42	0,5	25	55	59 mm	55 mm	A172.0XXX.025
		30	55	59 mm	55 mm	A172.0XXX.030
		45	55	59 mm	55 mm	A172.0XXX.045
		56	55	59 mm	55 mm	A172.0XXX.056
		67	55	59 mm	55 mm	A172.0XXX.067
42,5-48	0,5	30	62	66 mm	62 mm	A172.0XXX.030
		56	62	66 mm	62 mm	A172.0XXX.056
48,5-55	0,5	30	70	74 mm	70 mm	A172.0XXX.030
		56	70	74 mm	70 mm	A172.0XXX.056
		67	70	74 mm	70 mm	A172.0XXX.067
56-63	1	35	78	82 mm	78 mm	A172.0XXX.035
		67	78	82 mm	78 mm	A172.0XXX.067
		72	78	82 mm	78 mm	A172.0XXX.072
		78	78	82 mm	78 mm	A172.0XXX.078

 Lengths available only for certain range diameter

Material : 16CrNi4 – Case hardened

Hardness : 60 – 62 Hrc

Standard : DIN 179

Ordering example

Drill bushes \varnothing 6 mm length 10mm

Please state : Ref . A179.0600.010

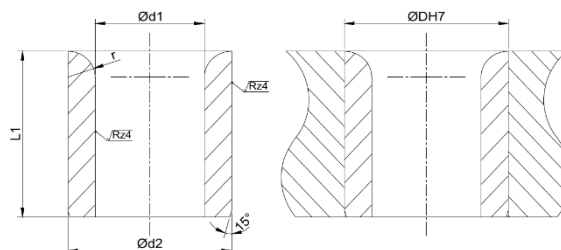

D1 F7	Gradation	L1	D2 n6	Positioning bore	References
0,9-1	0,1	6	3	3 mm	A179.0XXX.006
		9	3	3 mm	A179.0XXX.009
1,1-1,8	0,1	6	4	4 mm	A179.0XXX.006
		9	4	4 mm	A179.0XXX.009
1,9-2,6	0,1-0,25	6	5	5 mm	A179.0XXX.006
		9	5	5 mm	A179.0XXX.009
2,7-3,3	0,1-0,25	8	6	6 mm	A179.0XXX.008
		12	6	6 mm	A179.0XXX.012
		16	6	6 mm	A179.0XXX.016
3,4-4	0,1-0,25	8	7	7 mm	A179.0XXX.008
		12	7	7 mm	A179.0XXX.012
		16	7	7 mm	A179.0XXX.016
4,1-5	0,1-0,25	8	8	8 mm	A179.0XXX.008
		12	8	8 mm	A179.0XXX.012
		16	8	8 mm	A179.0XXX.016
5,1-6	0,1-0,25	10	10	10 mm	A179.0XXX.010
		16	10	10 mm	A179.0XXX.016
		20	10	10 mm	A179.0XXX.020
6,1-8	0,1-0,25	10	12	12 mm	A179.0XXX.010
		16	12	12 mm	A179.0XXX.016
		20	12	12 mm	A179.0XXX.020
8,1-10	0,1-0,25	12	15	15 mm	A179.0XXX.012
		20	15	15 mm	A179.0XXX.020
		25	15	15 mm	A179.0XXX.025
10,1-12	0,1-0,25	12	18	18 mm	A179.0XXX.012
		20	18	18 mm	A179.0XXX.020
		25	18	18 mm	A179.0XXX.025

To the complete list of reference

D1 F7	Gradation	L1	D2 n°	Positioning bore	References
12,1-15	0,25	16	22	22 mm	A179.0XXX.016
		28	22	22 mm	A179.0XXX.028
		36	22	22 mm	A179.0XXX.036
15,25-18	0,25	16	26	26 mm	A179.0XXX.016
		28	26	26 mm	A179.0XXX.028
		36	26	26 mm	A179.0XXX.036
18,25-22	0,25	20	30	30 mm	A179.0XXX.020
		36	30	30 mm	A179.0XXX.036
		45	30	30 mm	A179.0XXX.045
22,25-26	0,25	20	35	35 mm	A179.0XXX.020
		36	35	35 mm	A179.0XXX.036
		45	35	35 mm	A179.0XXX.045
26,25-30	0,25	20	42	42 mm	A179.0XXX.020
		25	42	42 mm	A179.0XXX.025
		36	42	42 mm	A179.0XXX.036
		45	42	42 mm	A179.0XXX.045
		56	42	42 mm	A179.0XXX.056
30,25-35	0,25	25	48	48 mm	A179.0XXX.025
		45	48	48 mm	A179.0XXX.045
		56	48	48 mm	A179.0XXX.056
35,5-42	0,5	25	55	55 mm	A179.0XXX.025
		30	55	55 mm	A179.0XXX.030
		45	55	55 mm	A179.0XXX.045
		56	55	55 mm	A179.0XXX.056
		67	55	55 mm	A179.0XXX.067
42,5-48	0,5	30	62	62 mm	A179.0XXX.030
		56	62	62 mm	A179.0XXX.056
48,5-55	0,5	30	70	70 mm	A179.0XXX.030
		56	70	70 mm	A179.0XXX.056
		67	70	70 mm	A179.0XXX.067
56-63	1	35	78	78 mm	A179.0XXX.035
		67	78	78 mm	A179.0XXX.067
		72	78	78 mm	A179.0XXX.072
		78	78	78 mm	A179.0XXX.078

 Lengths available only for certain range diameter

Material : 16CrNi4 – Case hardened

Hardness : 58 – 62 Hrc

Ordering example

Centring units Ø 16 mm length 34mm

Please state : Ref . PDC.016.034

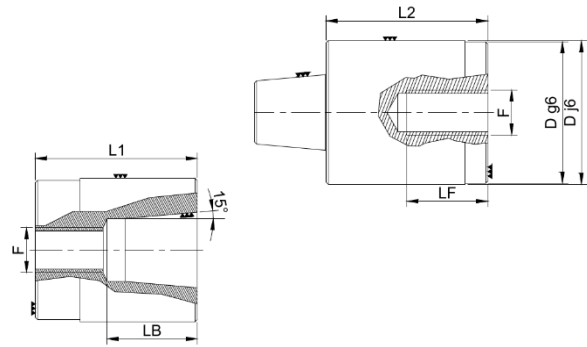

D1 j6	L	Male length L1	Female length L2	LB	LF	Thread F	References
12	34	17	17	8	10	M4	PDC.012.034
14	34	17	17	8	10	M5	PDC.014.034
16	34	17	17	8	10	M5	PDC.016.034
20	54	27	27	13	15	M8	PDC.020.054
25	54	27	27	15	15	M8	PDC.025.054
26	54	27	27	15	15	M8	PDC.026.054
30	72	36	36	20	18	M10	PDC.030.072
32	72	36	36	20	18	M10	PDC.032.072
40	92	46	46	25	18	M10	PDC.040.092
42	92	46	46	25	18	M10	PDC.042.092

NOTES

A large rectangular area containing horizontal dotted lines for writing notes.

INNOVATION

Guide and lifter kit made of a assembly of a band guide/lifter bloc, a lock washer and a screw.

The compression spring to be ordered separately.

Default value: $a=3$, other available upon request.

We do recommend a boring tolerance of H7.

Exemple de commande

Pour $C = 20$

Veuillez indiquer : Réf. **GIB.200**

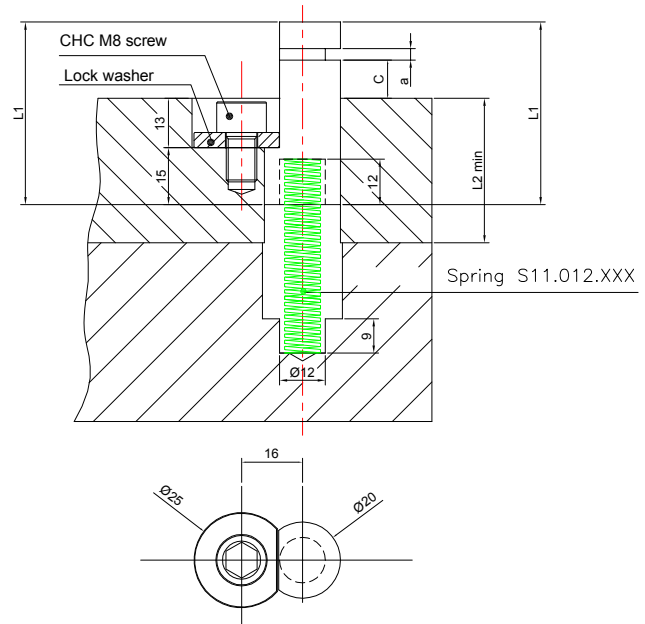
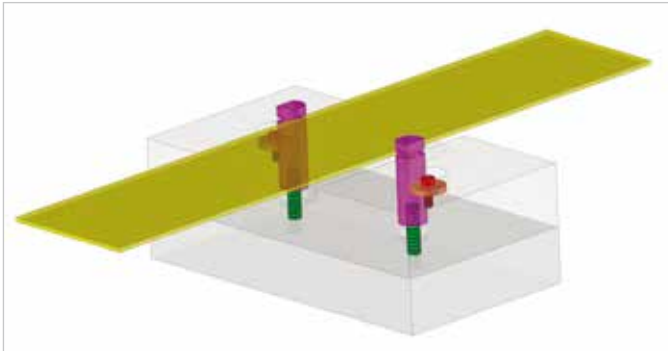

References	L1	L2 min minimum guiding	C	Spring advised not included	Lock washer included	Screw included
GIB.100	48	38	10	S11.012.051	GIB.005.025	A05.008.025
GIB.200	58	48	20	S11.012.064	GIB.005.025	A05.008.025
GIB.300	68	58	30	S11.012.076	GIB.005.025	A05.008.025

Large area with horizontal dotted lines for taking notes.

You can access to our gas strippers and spring ejectors portofolio in refering to our gas spring catalog.



AMDL www.amdl-eu.com

AMDL

AMDL SCOP SA
Aire d'activité du Florival
9 rue de l'Oberwald
FR-68500 ISSENHEIM
Tél : +33 (0)3 89 74 24 24
contact@amdl-eu.com

