

Die sets

MDL[®]



AMDL[®]
Atelier Mécanique De La Lauch



STANDARD DIE SETS CONTENTS

■ Standard die sets with centre pillars D61/D71	3
■ Standard die sets with rear pillars D72	4
■ Standard die sets with diagonal pillars D63/D73	5
■ Rectangular die sets with centre pillars D81/D91	6 - 7
■ Rectangular die sets with rear pillars D92	8 - 9
■ Rectangular die sets with diagonal pillars D83/D93	10 - 11
■ Rectangular die sets with four pillars D84/D94	12 - 13
■ Rectangular die sets with central pillars and ball bearing guide bushes D86/D96	14 - 15
■ Rectangular die sets with rear pillars and ball bearing guides D97	16 - 17
■ Rectangular die sets with diagonal pillars and ball bearing guides D88/D98	18 - 19
■ Rectangular die sets with four pillars and ball bearing guides D89/D99	20 - 21

In order to provide a better response to your urgent ordering requirements, we can offer you three new die set solutions:

- Standard die sets: 48-hours delivery ex works (See pages 3 to 5).
- Rectangular die sets: 72-hours delivery ex works (See pages 6 to 21).
- Made-to-measure die sets: according to your plans and specifications
- Special die sets: according to individual design requirements

By matching bushes and pillars, we can offer you three adjustment categories:

Category I : For tooling processing of very thin sheet metal.
For very fine clearance between punch and die sections.
Where clearance per side is less than 0.02 mm.

Category II : For tooling processing of sheet metal more than 0.4 mm thick
For clearance between punch and die sections from 0.02 to 0.06 mm per side.
For most applications.

Category III : For clearance between punch and die sections of 0.08 mm per side.
For automotive, forming dies.

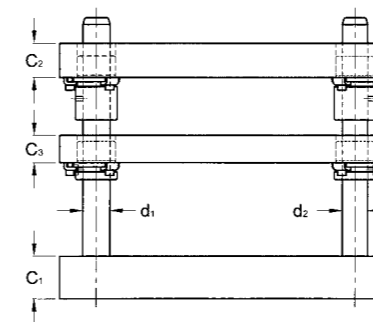

Standard die set with stripper plate Type D61.xxx.xxx

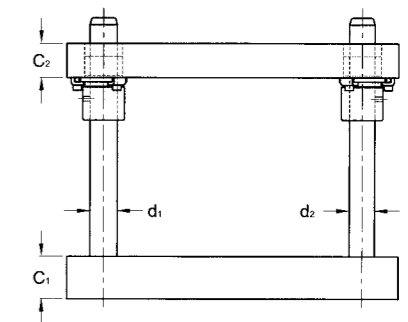

Standard die set Type D71.xxx.xxx

The plates are torch-cut and stress relieved.
The guide elements can be chosen from our catalogue:

- Straight pillars P10.xxx.xxx
- Demountable pillars P2x.xxx.xxx
- Steel bushes B1x.xxx.xxx
- Bronze-plated bushes B2x.xxx.xxx

Delivery: 48 hours ex works

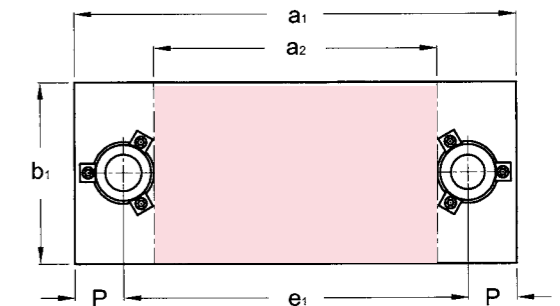

Examples

Die set with stripper plate : D61.012.010
Identical die set without stripper plate : D71.012.010

Ext. dimensions			C ₁ ±1	C ₂ ±1	C ₃ ±1	d ₁ /L	d ₂ /L	e ₁	P	Reference x = 6 : with C3 x = 7 : without C3
a ₂	b ₁	a ₁								
Work space										
100	80	225	32	25	25	25/160	24/160	147	39	Dx1.010.008
125		250						172		Dx1.012.008
160		285						207		Dx1.016.008
200		325						247		Dx1.020.008
100	100	225	32	25	25	25/160	24/160	147	39	Dx1.010.010
125		250						172		Dx1.012.010
160		285						207		Dx1.016.010
250		390						304		Dx1.025.010
125	125	265	40	32	28	32/180	30/180	179	43	Dx1.012.012
160		300						214		Dx1.016.012
200		340						254		Dx1.020.012
315		455						369		Dx1.031.012
160	160	300	50	40	32	32/200	30/200	214	52	Dx1.016.016
200		340						254		Dx1.020.016
250		390						304		Dx1.025.016
315		455						369		Dx1.031.016
200	200	367	50	40	32	40/220	38/220	263	52	Dx1.020.020
315		482						378		Dx1.031.020
315		482						378		Dx1.031.025

L : Pin Length recommendations

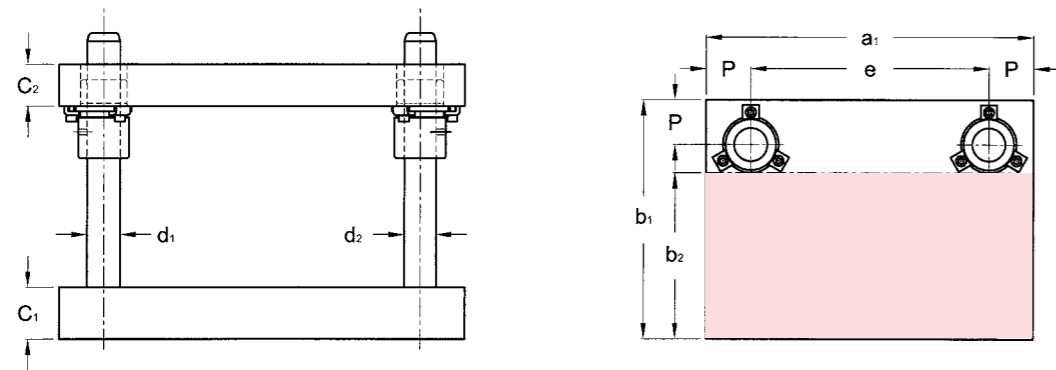

The plates are torch-cut and stress relieved.
The guide elements can be chosen from our catalogue:

- Straight pillars P10.xxx.xxx
- Demountable pillars P2x.xxx.xxx
- Steel bushes B1x.xxx.xxx
- Bronze-plated bushes B2x.xxx.xxx

Delivery: 48 hours ex works

Example Die set with rear pillars : **D72.031.010**

Ext. dimensions			C ₁ ±1	C ₂ ±1	d ₁ /L	e	P	Reference
a ₁	b ₂	b ₁						
Work space			40	32	25/180	39	39	D72.020.010
125								
160	63	108	D72.016.006					
200			D72.020.006					
160			32	25	25/180	82	39	D72.016.008
200	80	143						D72.020.008
250								D72.025.008
200			40	32	32/200	114	43	D72.020.012
250	125	195						D72.025.012
315								D72.031.012
250			50	40	40/200	164	52	D72.025.016
315	160	230						D72.031.016
315	200	284						D72.031.020

L : Pin Length recommendations



**Standard die set with stripper plate
type D63.xxx.xxx**

**Standard die set
type D73.xxx.xxx**

The plates are torch-cut and stress relieved.
The guide elements can be chosen from our catalogue :

- Straight pillars P10.xxx.xxx
- Demountable pillars P2x.xxx.xxx
- Steel bushes B1x.xxx.xxx
- Bronze-plated bushes B2x.xxx.xxx

Delivery: 48 hours ex works

Examples Die set with stripper plate : **D63.024.012**
Identical die set without stripper plate : **D73.024.012**

a ₁	b ₁	Ext. dimensions		C ₁ ±1	C ₂ ±1	C ₃ ±1	d ₁ /L	d ₂ /L	e ₁	e ₅	e ₄	t	w	Reference x = 6 : with C3 x = 7 : without C3	
		a ₂	b ₂												
Work space		235	260	32	25	25	25/180	24/180	193	147	125	78	271	Dx3.016.010	
165															
200	100	271		40	32	28	32/200	30/200	249	200			327	Dx3.024.010	
240		310							290	250		368	Dx3.029.010		
290		357							240	160		326	Dx3.020.012		
200		282	300	50	40	32	40/220	38/220	269	200			355	Dx3.024.012	
240	125	322								308	179	250		394	Dx3.029.012
290		371								363	315	86	449	Dx3.035.012	
355		433		50	40	32	40/220	38/220	293	200			379	Dx3.024.016	
240		322							329	214	250		415	Dx3.029.016	
290	160	372	335						381	315		467	Dx3.035.016		
355		435		50	40	32	40/220	38/220	363	250			467	Dx3.029.020	
290	200	398	410						411	263	315	104	515	Dx3.035.020	
355		462							444	313	315		548	Dx3.035.025	
355	250	462	460												

L : Pin Length recommendations

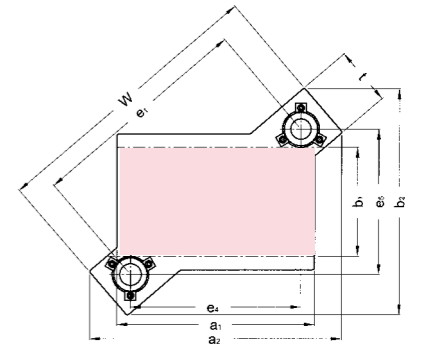

RECTANGULAR DIE SETS WITH CENTRE PILLARS

**D81
D91**

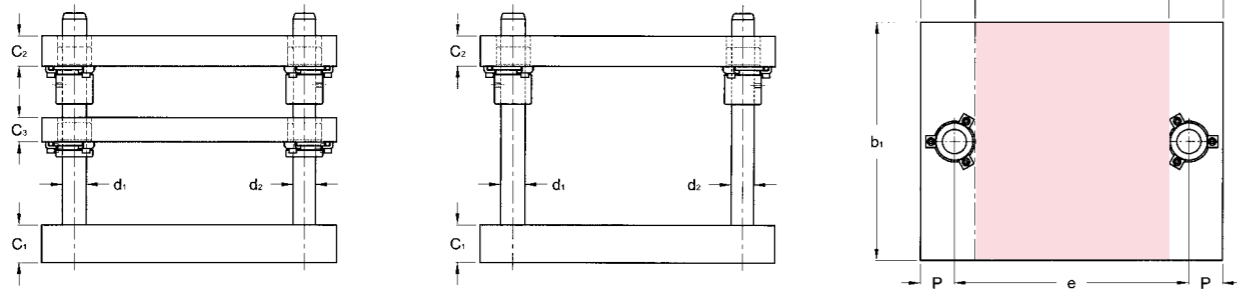

Standard assembly of bushes on underside of stripper plate.

Ext. dimensions			C ₁ ±1	C ₂ ±1	C ₃ ±1	d ₁ /L	d ₂ /L	e	P	reference x = 8 : with C3 x = 9 : without C3										
a ₁	b ₁	a ₂																		
250	160	127	32	32	32	25/200	24/200	174	38	Dx1.125.016										
			32	40						Dx1.225.016										
			40	32						Dx1.325.016										
			40	40						Dx1.425.016										
	200		32	32						32	25/200	24/200	174	38	Dx1.125.020					
			32	40											Dx1.225.020					
			40	32											Dx1.325.020					
			40	40											Dx1.425.020					
	250		32	32											32	25/200	24/200	174	38	Dx1.125.025
			32	40																Dx1.225.025
			40	32																Dx1.325.025
			40	40																Dx1.425.025
315	200	171	32	32	32	32/200	30/200	225	45											Dx1.131.020
			32	40																Dx1.231.020
			40	32																Dx1.331.020
			40	40																Dx1.431.020
	250		32	32						32	32/200	30/200	225	45						Dx1.131.025
			32	40																Dx1.231.025
			40	32																Dx1.331.025
			40	40																Dx1.431.025
	315		40	40											32	32/200	30/200	225	45	Dx1.131.031
			40	50																Dx1.231.031
			50	40																Dx1.331.031
			50	50																Dx1.431.031
400	200	256	40	40	32	32/220	30/220	310	45											Dx1.140.020
			40	50																Dx1.240.020
			50	40																Dx1.340.020
			50	50																Dx1.440.020
	250		40	40						32	32/220	30/220	310	45						Dx1.140.025
			40	50																Dx1.240.025
			50	40																Dx1.340.025
			50	50																Dx1.440.025
	315		40	40											32	32/220	30/220	310	45	Dx1.140.031
			40	50																Dx1.240.031
			50	40																Dx1.340.031
			50	50																Dx1.440.031
400	40	40	32	32/220	30/220	310	45	Dx1.140.040												
	40	50						Dx1.240.040												
	50	40						Dx1.340.040												
	50	50						Dx1.440.040												

L : Pin Length recommendations

RECTANGULAR DIE SETS WITH CENTRE PILLARS

**D81
D91**

The plates are torch-cut and stress relieved.
The steel or bronze-plated steel guide elements can be chosen from our "Guide Elements" catalogue.

Delivery: 72 hours ex works

Examples

Die set with stripper plate : D81.463.040
Identical die set without stripper plate : D91.463.040

Ext. dimensions a ₁	b ₁	a ₂	C ₁ ±1	C ₂ ±1	C ₃ ±1	d ₁ /L	d ₂ /L	e	P	Reference x = 8 : with C3 x = 9 : without C3										
											Work space									
500	250	337	40	40	32	40/220	38/220	400	50	Dx1.150.025										
			40	50						Dx1.250.025										
			50	40						Dx1.350.025										
			50	50						Dx1.450.025										
	315		40	40						32	40/220	38/220	400	50	Dx1.150.031					
			40	50											Dx1.250.031					
			50	40											Dx1.350.031					
			50	50											Dx1.450.031					
	400		40	40											32	40/220	38/220	400	50	Dx1.150.040
			40	50																Dx1.250.040
			50	40																Dx1.350.040
			50	50																Dx1.450.040
500	40	40	32	40/220	38/220	400	50	Dx1.150.050												
	40	50						Dx1.250.050												
	50	40						Dx1.350.050												
	50	50						Dx1.450.050												
630	315	435						50	50	40	50/220	48/220	510	60						Dx1.163.031
								50	58											Dx1.263.031
								58	50											Dx1.363.031
								58	58											Dx1.463.031
	400							50	50						40	50/220	48/220	510	60	Dx1.163.040
								50	58											Dx1.263.040
								58	50											Dx1.363.040
								58	58											Dx1.463.040
	500		50	50	40	50/220	48/220	510	60											Dx1.163.050
			50	58																Dx1.263.050
			58	50																Dx1.363.050
			58	58																Dx1.463.050
630	50	50	40	50/220						48/220	510	60	Dx1.163.063							
	50	58											Dx1.263.063							
	58	50											Dx1.363.063							
	58	58											Dx1.463.063							
710	400	515											58	58	40	50/250	48/250	590	60	Dx1.171.040
													58	63						Dx1.271.040
													63	58						Dx1.371.040
													63	63						Dx1.471.040
	500				58	58	40	50/250	48/250				590	60						Dx1.171.050
					58	63														Dx1.271.050
					63	58														Dx1.371.050
					63	63														Dx1.471.050
	630		58	58	40	50/250				48/250	590	60								Dx1.171.063
			58	63																Dx1.271.063
			63	58																Dx1.371.063
			63	63																Dx1.471.063

L : Pin Length recommendations

RECTANGULAR DIE SETS WITH REAR PILLARS

D92

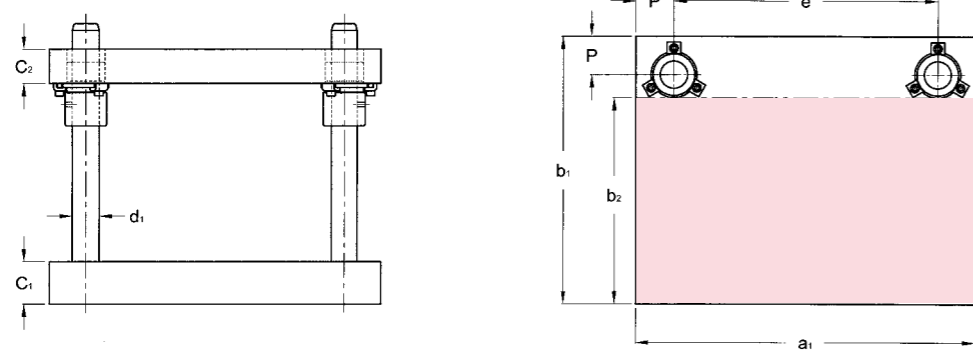

Ext. dimensions			C ₁ ±1	C ₂ ±1	d ₁ /L	e	P	Reference
a ₁	b ₂	b ₁						
Work space								
250	98	160	32	32	25/200	174	38	D92.125.016
			32	40				D92.225.016
			40	32				D92.325.016
			40	40				D92.425.016
	138	200	32	32				D92.125.020
			32	40				D92.225.020
			40	32				D92.325.020
			40	40				D92.425.020
	188	250	32	32				D92.125.025
			32	40				D92.225.025
			40	32				D92.325.025
			40	40				D92.425.025
315	128	200	32	32	32/200	225	45	D92.131.020
			32	40				D92.231.020
			40	32				D92.331.020
			40	40				D92.431.020
	178	250	32	32				D92.131.025
			32	40				D92.231.025
			40	32				D92.331.025
			40	40				D92.431.025
	243	315	40	40				D92.131.031
			40	50				D92.231.031
			50	40				D92.331.031
			50	50				D92.431.031
400	128	200	40	40	32/220	310	45	D92.140.020
			40	50				D92.240.020
			50	40				D92.340.020
			50	50				D92.440.020
	178	250	40	40				D92.140.025
			40	50				D92.240.025
			50	40				D92.340.025
			50	50				D92.440.025
	243	315	40	40				D92.140.031
			40	50				D92.240.031
			50	40				D92.340.031
			50	50				D92.440.031
318	400	40	40	D92.140.040				
		40	50	D92.240.040				
		50	40	D92.340.040				
		50	50	D92.440.040				

L : Pin Length recommendations

RECTANGULAR DIE SETS WITH REAR PILLARS

D92

The plates are torch-cut and stress relieved.
The steel or bronze-plated steel guide elements can be chosen from our "Guide Elements" catalogue.

Delivery: 72 hours ex works

Example Rectangular die set with rear pillars: **D92.450.050**

Ext. dimensions			C ₁ ±1	C ₂ ±1	d ₁ /L	e	P	Reference
a ₁	b ₂	b ₁						
Work space								
500	168	250	40	40	40/220	400	50	D92.150.025
			40	50				D92.250.025
			50	40				D92.350.025
			50	50				D92.450.025
	233	315	40	40				D92.150.031
			40	50				D92.250.031
			50	40				D92.350.031
			50	50				D92.450.031
	318	400	40	40				D92.150.040
			40	50				D92.250.040
			50	40				D92.350.040
			50	50				D92.450.040
418	500	40	40	D92.150.050				
		40	50	D92.250.050				
		50	40	D92.350.050				
		50	50	D92.450.050				
630	217	315	50	50	50/220	510	60	D92.163.031
			50	58				D92.263.031
			58	50				D92.363.031
			58	58				D92.463.031
	302	400	50	50				D92.163.040
			50	58				D92.263.040
			58	50				D92.363.040
			58	58				D92.463.040
	402	500	50	50				D92.163.050
			50	58				D92.263.050
			58	50				D92.363.050
			58	58				D92.463.050
532	630	50	50	D92.163.063				
		50	58	D92.263.063				
		58	50	D92.363.063				
		58	58	D92.463.063				
710	302	400	58	58	50/250	590	60	D92.171.040
			58	63				D92.271.040
			63	58				D92.371.040
			63	63				D92.471.040
	402	500	58	58				D92.171.050
			58	63				D92.271.050
			63	58				D92.371.050
			63	63				D92.471.050
	532	630	58	58				D92.171.063
			58	63				D92.271.063
			63	58				D92.371.063
			63	63				D92.471.063

L : Pin Length recommendations

RECTANGULAR DIE SETS WITH DIAGONAL PILLARS

**D83
D93**

RECTANGULAR DIE SETS WITH DIAGONAL PILLARS

**D83
D93**

The plates are torch-cut and stress relieved.
The steel or bronze-plated steel guide elements can be chosen from our "Guide Elements" catalogue.

Delivery : 72 hours ex works

Examples

Die set with stripper plate : D83.450.031
Identical die set without stripper plate : D93.450.031

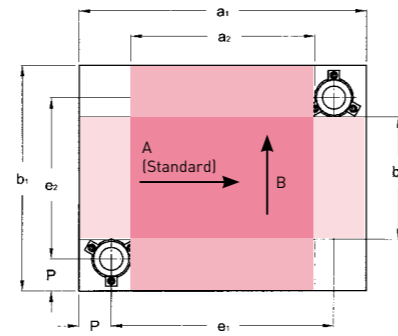
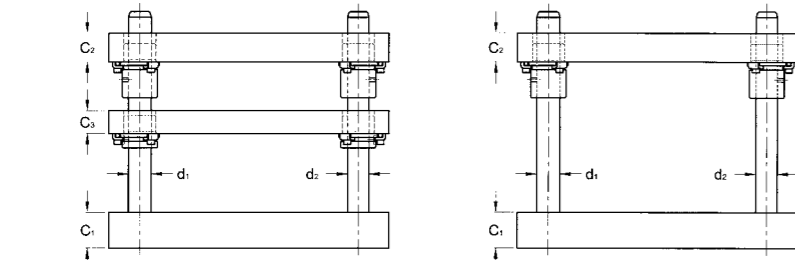

Standard assembly of bushes on underside of stripper plate.

Ext. dimensions				C ₁ ±1	C ₂ ±1	C ₃ ±1	d ₁ /L	d ₂ /L	e ₁	e ₂	P	Reference x = 8 : with C3 x = 9 : without C3
Work space, direction A		Work space, direction B										
a ₁	b ₂	b ₁	a ₂									
250	37	160	127	32	32	32	25/200	24/200	174	84	38	Dx3.125.016
				32	40							Dx3.225.016
				40	32							Dx3.325.016
				40	40							Dx3.425.016
	77	200	127	32	32					Dx3.125.020		
				32	40					Dx3.225.020		
				40	32					Dx3.325.020		
				40	40					Dx3.425.020		
	127	250	127	32	32					Dx3.125.025		
				32	40					Dx3.225.025		
				40	32					Dx3.325.025		
				40	40					Dx3.425.025		
315	56	200	171	32	32	32	32/200	30/200	225	110	45	Dx3.131.020
				32	40							Dx3.231.020
				40	32							Dx3.331.020
				40	40							Dx3.431.020
	106	250		171	32					32		Dx3.131.025
					32					40		Dx3.231.025
					40					32		Dx3.331.025
					40					40		Dx3.431.025
	171	315		171	40					40		Dx3.131.031
					40					50		Dx3.231.031
					50					40		Dx3.331.031
					50					50		Dx3.431.031
400	56	200	256	40	40	32	32/220	30/220	310	110	45	Dx3.140.020
				40	50							Dx3.240.020
				50	40							Dx3.340.020
				50	50							Dx3.440.020
	106	250		256	40					40		Dx3.140.025
					40					50		Dx3.240.025
					50					40		Dx3.340.025
					50					50		Dx3.440.025
	171	315		256	40					40		Dx3.140.031
					40					50		Dx3.240.031
					50					40		Dx3.340.031
					50					50		Dx3.440.031
256	400	256	40	40	Dx3.140.040							
			40	50	Dx3.240.040							
			50	40	Dx3.340.040							
			50	50	Dx3.440.040							

L : Pin Length recommendations

Ext. dimensions				C ₁ ±1	C ₂ ±1	C ₃ ±1	d ₁ /L	d ₂ /L	e ₁	e ₂	P	Références x = 8 : with C3 x = 9 : without C3
Work space, direction A		Work space, direction B										
a ₁	b ₂	b ₁	a ₂									
500	87	250	337	40	40	32	40/220	38/220	400	150	50	Dx3.150.025
				40	50							Dx3.250.025
				50	40							Dx3.350.025
				50	50							Dx3.450.025
	152	315		337	40					40		Dx3.150.031
					40					50		Dx3.250.031
					50					40		Dx3.350.031
					50					50		Dx3.450.031
	237	400		337	40					40		Dx3.150.040
					40					50		Dx3.250.040
					50					40		Dx3.350.040
					50					50		Dx3.450.040
337	500	337	40	40	Dx3.150.050							
			40	50	Dx3.250.050							
			50	40	Dx3.350.050							
			50	50	Dx3.450.050							
630	120	315	435	50	50	40	50/220	48/220	510	195	60	Dx3.163.031
				50	58							Dx3.263.031
				58	50							Dx3.363.031
				58	58							Dx3.463.031
	205	400		435	50					50		Dx3.163.040
					50					58		Dx3.263.040
					58					50		Dx3.363.040
					58					58		Dx3.463.040
	305	500		435	50					50		Dx3.163.050
					50					58		Dx3.263.050
					58					50		Dx3.363.050
					58					58		Dx3.463.050
435	630	435	50	50	Dx3.163.063							
			50	58	Dx3.263.063							
			58	50	Dx3.363.063							
			58	58	Dx3.463.063							
710	205	400	515	58	58	40	50/250	48/250	590	280	60	Dx3.171.040
				58	63							Dx3.271.040
				63	58							Dx3.371.040
				63	63							Dx3.471.040
	305	500		515	58					58		Dx3.171.050
					58					63		Dx3.271.050
					63					58		Dx3.371.050
					63					63		Dx3.471.050
	435	630		515	58					58		Dx3.171.063
					58					63		Dx3.271.063
					63					58		Dx3.371.063
					63					63		Dx3.471.063

L : Pin Length recommendations

RECTANGULAR DIE SETS WITH FOUR PILLARS

**D84
D94**

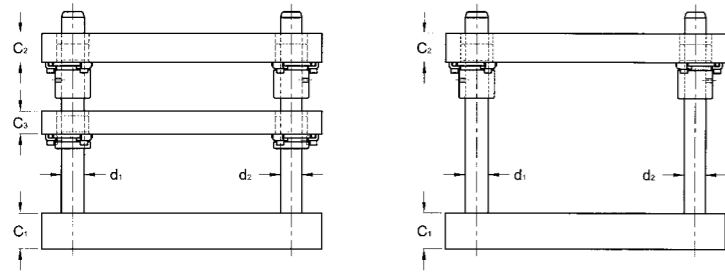

Standard assembly of bushes on underside of stripper plate.

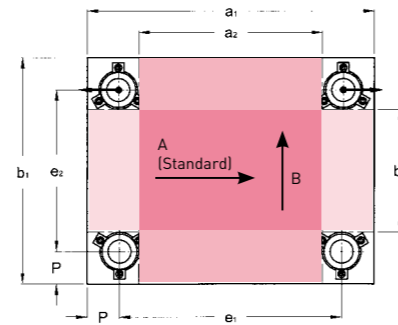

Ext. dimensions				C ₁ ±1	C ₂ ±1	C ₃ ±1	d ₁ /L	e ₁	e ₂	P	References x = 8 : with C3 x = 9 : without C3
Work space, direction A		Work space, direction B									
a ₁	b ₂	b ₁	a ₂								
250	37	160	127	32	32	32	25/200	174	84	38	Dx4.125.016
				32	40						Dx4.225.016
				40	32						Dx4.325.016
				40	40						Dx4.425.016
	77	200	127	32	32				Dx4.125.020		
				32	40				Dx4.225.020		
				40	32				Dx4.325.020		
				40	40				Dx4.425.020		
	127	250	192	32	32				Dx4.125.025		
				32	40				Dx4.225.025		
				40	32				Dx4.325.025		
				40	40				Dx4.425.025		
315	77	200	192	32	32	32	25/200	239	124	38	Dx4.131.020
				32	40						Dx4.231.020
				40	32						Dx4.331.020
				40	40						Dx4.431.020
	127	250	192	32	32				Dx4.131.025		
				32	40				Dx4.231.025		
				40	32				Dx4.331.025		
				40	40				Dx4.431.025		
	192	315	277	40	40				Dx4.131.031		
				40	50				Dx4.231.031		
				50	40				Dx4.331.031		
				50	50				Dx4.431.031		
400	77	200	277	40	40	32	25/200	324	124	38	Dx4.140.020
				40	50						Dx4.240.020
				50	40						Dx4.340.020
				50	50						Dx4.440.020
	127	250	256	40	40				Dx4.140.025		
				40	50				Dx4.240.025		
				50	40				Dx4.340.025		
				50	50				Dx4.440.025		
	171	315	256	40	40				Dx4.140.031		
				40	50				Dx4.240.031		
				50	40				Dx4.340.031		
				50	50				Dx4.440.031		
256	400	256	40	40	Dx4.140.040						
			40	50	Dx4.240.040						
			50	40	Dx4.340.040						
			50	50	Dx4.440.040						

L : Pin Length recommendations

RECTANGULAR DIE SETS WITH FOUR PILLARS

**D84
D94**

The plates are torch-cut and stress relieved.
The steel or bronze-plated steel guide elements can be chosen from our "Guide Elements" catalogue.
The two rear pillars are offset by two mm towards the outside for foolproofing.

Delivery: 72 hours ex works

Examples

Die set with stripper plate : D84.450.031
Identical die set without stripper plate : D94.450.031

Ext. dimensions				C ₁ ±1	C ₂ ±1	C ₃ ±1	d ₁ /L	e ₁	e ₂	P	References x = 8 : with C3 x = 9 : without C3
Work space, direction A		Work space, direction B									
a ₁	b ₂	b ₁	a ₂								
500	106	250	356	40	40	32	32/220	410	160	45	Dx4.150.025
				40	50						Dx4.250.025
				50	40						Dx4.350.025
				50	50						Dx4.450.025
	171	315	356	40	40				Dx4.150.031		
				40	50				Dx4.250.031		
				50	40				Dx4.350.031		
				50	50				Dx4.450.031		
	256	400	356	40	40				Dx4.150.040		
				40	50				Dx4.250.040		
				50	40				Dx4.350.040		
				50	50				Dx4.450.040		
356	500	356	40	40	Dx4.150.050						
			40	50	Dx4.250.050						
			50	40	Dx4.350.050						
			50	50	Dx4.450.050						
630	152	315	467	50	50	40	40/220	530	215	50	Dx4.163.031
				50	58						Dx4.263.031
				58	50						Dx4.363.031
				58	58						Dx4.463.031
	237	400		467	50				50		Dx4.163.040
					50				58		Dx4.263.040
					58				50		Dx4.363.040
					58				58		Dx4.463.040
	337	500		467	50				50		Dx4.163.050
					50				58		Dx4.263.050
					58				50		Dx4.363.050
					58				58		Dx4.463.050
467	630	467	50	50	Dx4.163.063						
			50	58	Dx4.263.063						
			58	50	Dx4.363.063						
			58	58	Dx4.463.063						
710	205	400	515	58	58	40	50/250	590	280	60	Dx4.171.040
				58	63						Dx4.271.040
				63	58						Dx4.371.040
				63	63						Dx4.471.040
	305	500		515	58				58		Dx4.171.050
					58				63		Dx4.271.050
					63				58		Dx4.371.050
					63				63		Dx4.471.050
	435	630		515	58				58		Dx4.171.063
					58				63		Dx4.271.063
					63				58		Dx4.371.063
					63				63		Dx4.471.063

L : Pin Length recommendations

RECTANGULAR DIE SETS WITH CENTRAL PILLARS AND BALL BEARING GUIDE BUSHES

D86
D96

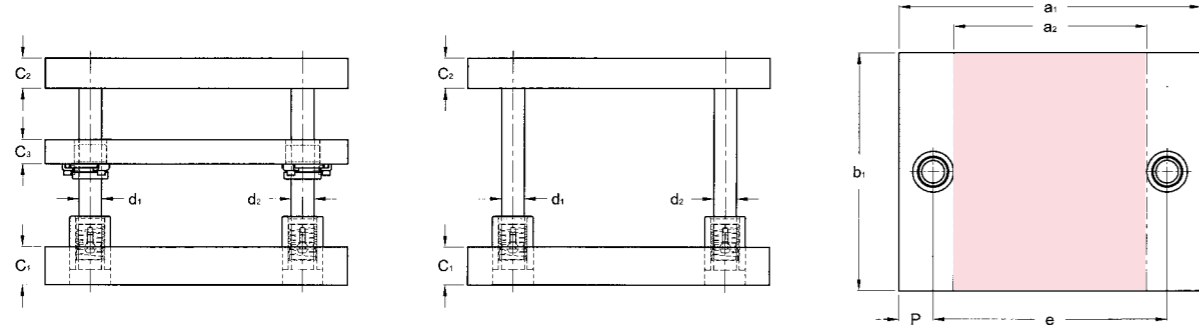

Standard assembly of bushes on stripper plate :
- on underside for demountable guide bushes (B1x.xxx.xxx and B2x.xxx.xxx)
- on top side for ball bearing guide bushes (B4x.xxx.xxx)

Ext. dimensions	a ₁	b ₁	a ₂	C ₁ ±1	C ₂ ±1	C ₃ ±1	d ₁ /L	d ₂ /L	e	P	Reference x = 8 : with C3 x = 9 : without C3	
		Work space										
250	160	120	32	32	32	32	25/200	24/200	165	42,5	Dx6.125.016	
				32	40						Dx6.225.016	
				40	32						Dx6.325.016	
				40	40						Dx6.425.016	
				32	32						Dx6.125.020	
				32	40						Dx6.225.020	
	200	120	32	40	32	32	25/200	24/200	165	42,5	42,5	Dx6.325.020
				40	40							Dx6.425.020
				32	32							Dx6.125.025
				32	40							Dx6.225.025
				40	32							Dx6.325.025
				40	40							Dx6.425.025
315	200	170	32	32	32	32	32/200	30/200	224	45,5	Dx6.131.020	
				32	40						Dx6.231.020	
				40	32						Dx6.331.020	
				40	40						Dx6.431.020	
	250	170	32	32	32	32	32/200	30/200	224	45,5	45,5	Dx6.131.025
				32	40							Dx6.231.025
				40	32							Dx6.331.025
				40	40							Dx6.431.025
	315	170	32	40	40	32	32/200	30/200	224	45,5	45,5	Dx6.131.031
				40	50							Dx6.231.031
				50	40							Dx6.331.031
				50	50							Dx6.431.031
400	200	255	40	40	40	32	32/200	30/200	309	45,5	Dx6.140.020	
				40	50						Dx6.240.020	
				50	40						Dx6.340.020	
				50	50						Dx6.440.020	
	250	255	32	40	40	32	32/200	30/200	309	45,5	45,5	Dx6.140.025
				40	50							Dx6.240.025
				50	40							Dx6.340.025
				50	50							Dx6.440.025
	315	255	32	40	40	32	32/200	30/200	309	45,5	45,5	Dx6.140.031
				40	50							Dx6.240.031
				50	40							Dx6.340.031
				50	50							Dx6.440.031
400	255	32	40	40	32	32/200	30/200	309	45,5	45,5	Dx6.140.040	
			40	50							Dx6.240.040	
			50	40							Dx6.340.040	
			50	50							Dx6.440.040	

L : Pin Length recommendations

RECTANGULAR DIE SETS WITH CENTRAL PILLARS AND BALL BEARING GUIDE BUSHES

D86
D96

The plates are torch-cut and stress relieved.
The guide elements with ball bearings (bush B30.xxx.xxx) can be chosen from our "Guide Elements" catalogue.

Please note: The work space is reduced if B40 or B42 bushes are used (see pages 9 and 10 - position of clamps - dimensions Q1 and Q2).

Delivery: 72 hours ex works

Examples

Die set with stripper plate: D86.463.040
Identical die set without stripper plate: D96.463.040

Ext. dimensions	a ₁	b ₁	a ₂	C ₁ ±1	C ₂ ±1	C ₃ ±1	d ₁ /L	d ₂ /L	e	P	Reference x = 8 : with C3 x = 9 : without C3	
												Work space
500	250	330	32	40	40	32	40/220	38/220	395	52,5	Dx6.150.025	
				40	50						Dx6.250.025	
				50	40						Dx6.350.025	
				50	50						Dx6.450.025	
	315	330	32	40	40	32	40/220	38/220	395	52,5	52,5	Dx6.150.031
				40	50							Dx6.250.031
				50	40							Dx6.350.031
				50	50							Dx6.450.031
	400	330	32	40	40	32	40/220	38/220	395	52,5	52,5	Dx6.150.040
				40	50							Dx6.250.040
				50	40							Dx6.350.040
				50	50							Dx6.450.040
500	330	32	40	40	32	40/220	38/220	395	52,5	52,5	Dx6.150.050	
			40	50							Dx6.250.050	
			50	40							Dx6.350.050	
			50	50							Dx6.450.050	
630	315	429	40	50	50	40	50/220	48/220	510	60	Dx6.163.031	
				50	58						Dx6.263.031	
				58	50						Dx6.363.031	
				58	58						Dx6.463.031	
	400	429	40	50	50	40	50/220	48/220	510	60	60	Dx6.163.040
				50	58							Dx6.263.040
				58	50							Dx6.363.040
				58	58							Dx6.463.040
	500	429	40	50	50	40	50/220	48/220	510	60	60	Dx6.163.050
				50	58							Dx6.263.050
				58	50							Dx6.363.050
				58	58							Dx6.463.050
630	429	40	50	50	40	50/220	48/220	510	60	60	Dx6.163.063	
			50	58							Dx6.263.063	
			58	50							Dx6.363.063	
			58	58							Dx6.463.063	
710	400	509	40	58	58	40	50/250	48/250	590	60	Dx6.171.040	
				58	63						Dx6.271.040	
				63	58						Dx6.371.040	
				63	63						Dx6.471.040	
	500	509	40	58	58	40	50/250	48/250	590	60	60	Dx6.171.050
				58	63							Dx6.271.050
				63	58							Dx6.371.050
				63	63							Dx6.471.050
	630	509	40	58	58	40	50/250	48/250	590	60	60	Dx6.171.063
				58	63							Dx6.271.063
				63	58							Dx6.371.063
				63	63							Dx6.471.063

L : Pin Length recommendations

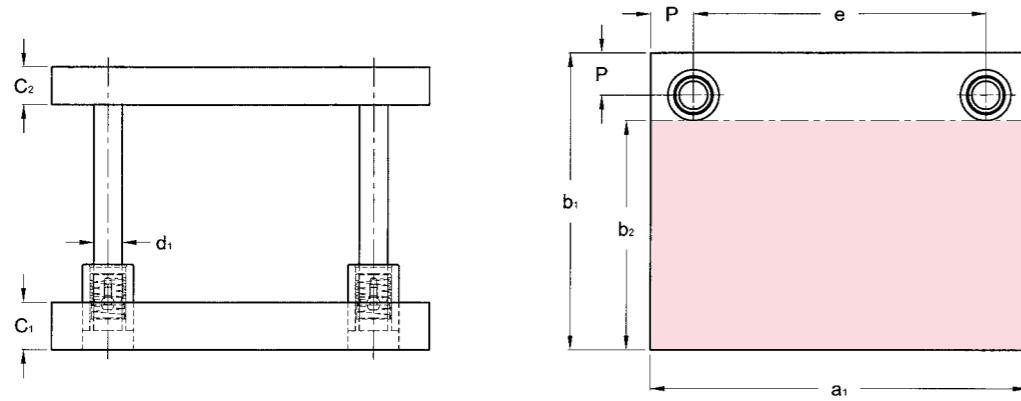

Ext. dimensions			C ₁ ±1	C ₂ ±1	d ₁ /L	e	P	Reference
a ₁	b ₂	b ₁						
Work space								
250	93	160	32	32	32/200	170	40	D97.125.016
			32	40				D97.225.016
			40	32				D97.325.016
			40	40				D97.425.016
	133	200	32	32				D97.125.020
			32	40				D97.225.020
			40	32				D97.325.020
			40	40				D97.425.020
	183	250	32	32				D97.125.025
			32	40				D97.225.025
			40	32				D97.325.025
			40	40				D97.425.025
315	128	200	32	32	32/200	225	45	D97.131.020
			32	40				D97.231.020
			40	32				D97.331.020
			40	40				D97.431.020
	178	250	32	32				D97.131.025
			32	40				D97.231.025
			40	32				D97.331.025
			40	40				D97.431.025
	243	315	40	40				D97.131.031
			40	50				D97.231.031
			50	40				D97.331.031
			50	50				D97.431.031
400	128	200	40	40	32/220	310	45	D97.140.020
			40	50				D97.240.020
			50	40				D97.340.020
			50	50				D97.440.020
	178	250	40	40				D97.140.025
			40	50				D97.240.025
			50	40				D97.340.025
			50	50				D97.440.025
	230	315	40	40				D97.140.031
			40	50				D97.240.031
			50	40				D97.340.031
			50	50				D97.440.031
315	400	40	40	D97.140.040				
		40	50	D97.240.040				
		50	40	D97.340.040				
		50	50	D97.440.040				

L : Pin Length recommendations

The plates are torch-cut and stress relieved.
The guide elements with ball bearings (bush B30.xxx.xxx) can be chosen from our "Guide Elements" catalogue.

Please note: The work space is reduced if B40 bushes are used
(see pages 9 - position of clamps - dimensions Q1 and Q2).

Delivery: 72 hours ex works

Example Rectangular stock die set with rear ball bearing guides: **D97.350.040**

Ext. dimensions			C ₁ ±1	C ₂ ±1	d ₁ /L	e	P	Reference
a ₁	b ₂	b ₁						
Work space								
500	157	250	40	40	40/220	395	52,5	D97.150.025
			40	50				D97.250.025
			50	40				D97.350.025
			50	50				D97.450.025
	222	315	40	40				D97.150.031
			40	50				D97.250.031
			50	40				D97.350.031
			50	50				D97.450.031
	307	400	40	40				D97.150.040
			40	50				D97.250.040
			50	40				D97.350.040
			50	50				D97.450.040
407	500	40	40	D97.150.050				
		40	50	D97.250.050				
		50	40	D97.350.050				
		50	50	D97.450.050				
630	206	315	50	50	50/220	510	60	D97.163.031
			50	58				D97.263.031
			58	50				D97.363.031
			58	58				D97.463.031
	291	400	50	50				D97.163.040
			50	58				D97.263.040
			58	50				D97.363.040
			58	58				D97.463.040
	391	500	50	50				D97.163.050
			50	58				D97.263.050
			58	50				D97.363.050
			58	58				D97.463.050
521	630	50	50	D97.163.063				
		50	58	D97.263.063				
		58	50	D97.363.063				
		58	58	D97.463.063				
710	291	400	58	58	50/250	590	60	D97.171.040
			58	63				D97.271.040
			63	58				D97.371.040
			63	63				D97.471.040
	391	500	58	58				D97.171.050
			58	63				D97.271.050
			63	58				D97.371.050
			63	63				D97.471.050
	521	630	58	58				D97.171.063
			58	63				D97.271.063
			63	58				D97.371.063
			63	63				D97.471.063

L : Pin Length recommendations

RECTANGULAR DIE SETS WITH DIAGONAL PILLARS AND BALL BEARING GUIDES

D88
D98

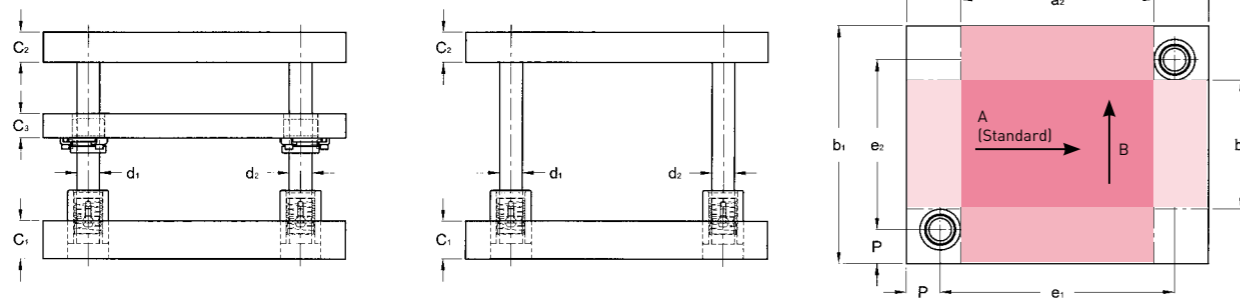

Standard assembly of bushes on stripper plate :
- on underside for demountable guide bushes (B1x.xxx.xxx and B2x.xxx.xxx)
- on top side for ball bearing guide bushes (B4x.xxx.xxx)

Ext. dimensions				C ₁ ±1	C ₂ ±1	C ₃ ±1	d ₁ /L	d ₂ /L	e ₁	e ₂	P	Reference x = 8 : with C3 x = 9 : without C3
Work space, direction A		Work space, direction B										
a ₁	b ₂	b ₁	a ₂									
250	30	160	120	32	32	32	25/200	24/200	165	75	42,5	Dx8.125.016
				32	40							Dx8.225.016
				40	32							Dx8.325.016
				40	40							Dx8.425.016
	70	200	120	32	32					Dx8.125.020		
				32	40					Dx8.225.020		
				40	32					Dx8.325.020		
				40	40					Dx8.425.020		
	120	250	120	32	32					Dx8.125.025		
				32	40					Dx8.225.025		
				40	32					Dx8.325.025		
				40	40					Dx8.425.025		
315	56	200	171	32	32	32	32/200	30/200	225	110	45	Dx8.131.020
				32	40							Dx8.231.020
				40	32							Dx8.331.020
				40	40							Dx8.431.020
	106	250	171	32	32					Dx8.131.025		
				32	40					Dx8.231.025		
				40	32					Dx8.331.025		
				40	40					Dx8.431.025		
	171	315	171	40	40					Dx8.131.031		
				40	50					Dx8.231.031		
				50	40					Dx8.331.031		
				50	50					Dx8.431.031		
400	56	200	260	40	40	32	32/200	30/200	310	110	45	Dx8.140.020
				40	50							Dx8.240.020
				50	40							Dx8.340.020
				50	50							Dx8.440.020
	106	250	260	40	40					Dx8.140.025		
				40	50					Dx8.240.025		
				50	40					Dx8.340.025		
				50	50					Dx8.440.025		
	171	315	260	40	40					Dx8.140.031		
				40	50					Dx8.240.031		
				50	40					Dx8.340.031		
				50	50					Dx8.440.031		
256	400	260	40	40	Dx8.140.040							
			40	50	Dx8.240.040							
			50	40	Dx8.340.040							
			50	50	Dx8.440.040							

L : Pin Length recommendations

RECTANGULAR DIE SETS WITH DIAGONAL PILLARS AND BALL BEARING GUIDES

D88
D98

The plates are torch-cut and stress relieved.
The guide elements with ball bearings (bush B30.xxx.xxx) can be chosen from our "Guide Elements" catalogue.

Please note: The work space is reduced if B40 bushes are used
(see page 9 and 10 - position of clamps - dimensions Q1 and Q2).

Delivery: 72 hours ex works

Examples

Die set with stripper plate: D88.125.016
Identical die set without stripper plate: D98.125.016

Ext. dimensions				C ₁ ±1	C ₂ ±1	C ₃ ±1	d ₁ /L	d ₂ /L	e ₁	e ₂	P	Reference x = 8 : with C3 x = 9 : without C3
Work space, direction A		Work space, direction B										
a ₁	b ₂	b ₁	a ₂									
500	80	250	330	40	40	32	40/220	38/220	395	145	52,5	Dx8.150.025
				40	50							Dx8.250.025
				50	40							Dx8.350.025
				50	50							Dx8.450.025
	145	315	330	40	40					Dx8.150.031		
				40	50					Dx8.250.031		
				50	40					Dx8.350.031		
				50	50					Dx8.450.031		
	230	400	330	40	40					Dx8.150.040		
				40	50					Dx8.250.040		
				50	40					Dx8.350.040		
				50	50					Dx8.450.040		
330	500	330	40	40	Dx8.150.050							
			40	50	Dx8.250.050							
			50	40	Dx8.350.050							
			50	50	Dx8.450.050							
630	114	315	429	50	50	40	50/220	48/220	510	195	60	Dx8.163.031
				50	58							Dx8.263.031
				58	50							Dx8.363.031
				58	58							Dx8.463.031
	199	400	429	50	50					Dx8.163.040		
				50	58					Dx8.263.040		
				58	50					Dx8.363.040		
				58	58					Dx8.463.040		
	299	500	429	50	50					Dx8.163.050		
				50	58					Dx8.263.050		
				58	50					Dx8.363.050		
				58	58					Dx8.463.050		
429	630	429	50	50	Dx8.163.063							
			50	58	Dx8.263.063							
			58	50	Dx8.363.063							
			58	58	Dx8.463.063							
710	199	400	509	58	58	40	50/250	48/250	590	280	60	Dx8.171.040
				58	63							Dx8.271.040
				63	58							Dx8.371.040
				63	63							Dx8.471.040
	299	500	509	58	58					Dx8.171.050		
				58	63					Dx8.271.050		
				63	58					Dx8.371.050		
				63	63					Dx8.471.050		
	429	630	509	58	58					Dx8.171.063		
				58	63					Dx8.271.063		
				63	58					Dx8.371.063		
				63	63					Dx8.471.063		

L : Pin Length recommendations

RECTANGULAR DIE SETS

WITH FOUR PILLARS AND BALL BEARING GUIDES

D89
D99

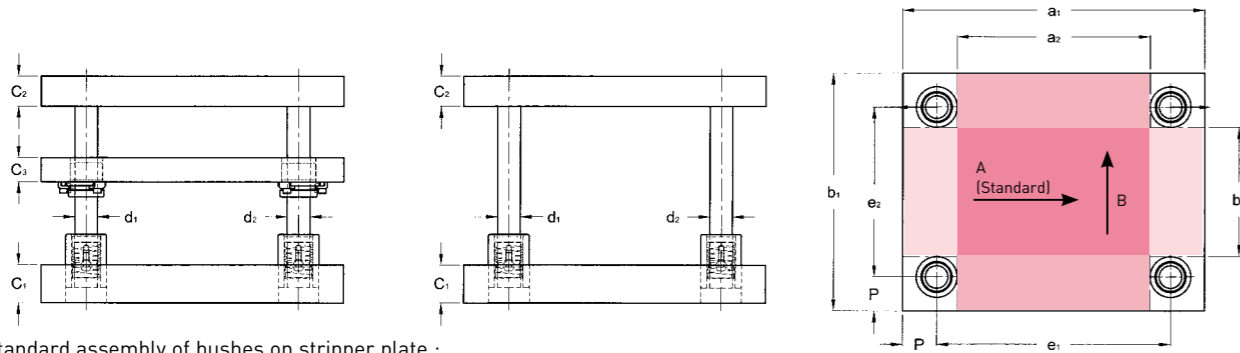

Standard assembly of bushes on stripper plate :
 - on underside for demountable guide bushes (B1x.xxx.xxx and B2x.xxx.xxx)
 - on top side for ball bearing guide bushes (B4x.xxx.xxx)

Ext. dimensions				C ₁ ±1	C ₂ ±1	C ₃ ±1	d ₁ /L	e ₁	e ₂	P	Reference x = 8 : with C3 x = 9 : without C3						
Work space, direction A		Work space, direction B															
a ₁	b ₂	b ₁	a ₂														
250	30	160	120	32	32	32	25/200	165	75	42,5	Dx9.125.016 Dx9.225.016 Dx9.325.016 Dx9.425.016 Dx9.125.020 Dx9.225.020 Dx9.325.020 Dx9.425.020 Dx9.125.025 Dx9.225.025 Dx9.325.025 Dx9.425.025						
				32	40												
				40	32												
				40	40												
	70	200	120	32	32				32			25/200	165	115	165	42,5	Dx9.125.020 Dx9.225.020 Dx9.325.020 Dx9.425.020 Dx9.125.025 Dx9.225.025 Dx9.325.025 Dx9.425.025
				32	40												
				40	32												
				40	40												
	120	250	120	32	32				32			25/200	165	165	165	42,5	Dx9.125.025 Dx9.225.025 Dx9.325.025 Dx9.425.025
				32	40												
				40	32												
				40	40												
315	70	200	185	32	32	32	25/200	230	115	42,5	Dx9.131.020 Dx9.231.020 Dx9.331.020 Dx9.431.020 Dx9.131.025 Dx9.231.025 Dx9.331.025 Dx9.431.025 Dx9.131.031 Dx9.231.031 Dx9.331.031 Dx9.431.031						
				32	40												
				40	32												
				40	40												
	120	250	185	32	32				32			25/200	230	165	230	42,5	Dx9.131.025 Dx9.231.025 Dx9.331.025 Dx9.431.025
				32	40												
				40	32												
				40	40												
	185	315	185	40	40				32			25/200	230	230	230	42,5	Dx9.131.031 Dx9.231.031 Dx9.331.031 Dx9.431.031
				40	50												
				50	40												
				50	50												
400	70	200	270	40	40	32	25/200	315	115	42,5	Dx9.140.020 Dx9.240.020 Dx9.340.020 Dx9.440.020 Dx9.140.025 Dx9.240.025 Dx9.340.025 Dx9.440.025						
				40	50												
				50	40												
				50	50												
	120	250	270	40	40				32			25/200	315	165	165	42,5	Dx9.140.031 Dx9.240.031 Dx9.340.031 Dx9.440.031
				40	50												
				50	40												
				50	50												
	165	315	270	40	40				32			25/200	315	219	219	48	Dx9.140.040 Dx9.240.040 Dx9.340.040 Dx9.440.040
				40	50												
				50	40												
				50	50												
250	400	270	40	40	32	25/200	315	304	304	48	Dx9.140.040 Dx9.240.040 Dx9.340.040 Dx9.440.040						
			40	50													
			50	40													
			50	50													

L : Pin Length recommendations

RECTANGULAR DIE SETS

WITH FOUR PILLARS AND BALL BEARING GUIDES

D89
D99

The plates are torch-cut and stress relieved.
 The guide elements with ball bearings (bush B30.xxx.xxx) can be chosen from our "Guide Elements" catalogue.

Please note: The work space is reduced if B40 bushes are used
 (see pages 9 and 10 - position of clamps - dimensions Q1 and Q2).

Delivery: 72 hours ex works

Examples

Die set with stripper plate: D89.125.016
 Identical die set without stripper plate: D99.125.016

Ext. dimensions				C ₁ ±1	C ₂ ±1	C ₃ ±1	d ₁ /L	e ₁	e ₂	P	Reference x = 8 : with C3 x = 9 : without C3						
Work space, direction A		Work space, direction B															
a ₁	b ₂	b ₁	a ₂														
500	100	250	350	40	40	32	32/220	404	154	48	Dx9.150.025 Dx9.250.025 Dx9.350.025 Dx9.450.025 Dx9.150.031 Dx9.250.031 Dx9.350.031 Dx9.450.031 Dx9.150.040 Dx9.250.040 Dx9.350.040 Dx9.450.040 Dx9.150.050 Dx9.250.050 Dx9.350.050 Dx9.450.050						
				40	50												
				50	40												
				50	50												
	165	315	350	40	40				32			32/220	404	219	48	48	Dx9.150.031 Dx9.250.031 Dx9.350.031 Dx9.450.031 Dx9.150.040 Dx9.250.040 Dx9.350.040 Dx9.450.040 Dx9.150.050 Dx9.250.050 Dx9.350.050 Dx9.450.050
				40	50												
				50	40												
				50	50												
	250	400	350	40	40				32			32/220	404	304	48	48	Dx9.150.040 Dx9.250.040 Dx9.350.040 Dx9.450.040 Dx9.150.050 Dx9.250.050 Dx9.350.050 Dx9.450.050
				40	50												
				50	40												
				50	50												
350	500	350	40	40	32	32/220	404	404	48	48	Dx9.150.050 Dx9.250.050 Dx9.350.050 Dx9.450.050						
			40	50													
			50	40													
			50	50													
630	140	315	455	50	50	40	40/220 520	520	205	55	Dx9.163.031 Dx9.263.031 Dx9.363.031 Dx9.463.031 Dx9.163.040 Dx9.263.040 Dx9.363.040 Dx9.463.040 Dx9.163.050 Dx9.263.050 Dx9.363.050 Dx9.463.050 Dx9.163.063 Dx9.263.063 Dx9.363.063 Dx9.463.063						
				50	58												
				58	50												
				58	58												
	225	400	455	50	50				40			40/220 520	520	290	55	55	Dx9.163.040 Dx9.263.040 Dx9.363.040 Dx9.463.040 Dx9.163.050 Dx9.263.050 Dx9.363.050 Dx9.463.050 Dx9.163.063 Dx9.263.063 Dx9.363.063 Dx9.463.063
				50	58												
				58	50												
				58	58												
	325	500	455	50	50				40			40/220 520	520	390	55	55	Dx9.163.050 Dx9.263.050 Dx9.363.050 Dx9.463.050 Dx9.163.063 Dx9.263.063 Dx9.363.063 Dx9.463.063
				50	58												
				58	50												
				58	58												
455	630	455	50	50	40	40/220 520	520	520	55	55	Dx9.163.063 Dx9.263.063 Dx9.363.063 Dx9.463.063						
			50	58													
			58	50													
			58	58													
710	190	400	500	58	58	40	50/250	581	271	64,5	Dx9.171.040 Dx9.271.040 Dx9.371.040 Dx9.471.040 Dx9.171.050 Dx9.271.050 Dx9.371.050 Dx9.471.050 Dx9.171.063 Dx9.271.063 Dx9.371.063 Dx9.471.063						
				58	63												
				63	58												
				63	63												
	290	500	500	58	58				40			50/250	581	371	64,5	64,5	Dx9.171.050 Dx9.271.050 Dx9.371.050 Dx9.471.050 Dx9.171.063 Dx9.271.063 Dx9.371.063 Dx9.471.063
				58	63												
				63	58												
				63	63												
	420	630	500	58	58				40			50/250	581	501	64,5	64,5	Dx9.171.063 Dx9.271.063 Dx9.371.063 Dx9.471.063
				58	63												
				63	58												
				63	63												

L : Pin Length recommendations



DIE SETS - MACHINED PLATES ACCORDING TO DRAWING CONTENTS

■ Machine capacities	24
■ Special die sets	25
■ MDL geometric standards	26
■ Dimensioning instructions for special rectangular die sets	27
■ Machined plates	28
■ The KIT - Die Sets	29

We perform machining on CNC machines.

CNC TORCH CUTTING Max. L x W x thickness: 6,000 x 2,300 x 250 mm
Tolerance to ± 2 mm

STRESS RELIEVING L x W x H max.: 4,500 x 2,300 x 1,600 mm
Max. load: 20 T

MACHINING

Grinding: Blancard and tangential-type. Max.load: 2T
Max. diagonal: 2,200 mm

Milling on machining centre
Max. stroke (X) : X x Y x Z: 3,650 x 1,750 x 710 mm Max. load: 9 T
Max. stroke (Y and Z) : X x Y x Z: 3,000 x 2,500 x 1,000 mm Max. load: 6 T
Large capacity : X x Y x Z: 4,010 x 2,500 x 670 mm Max. load: 15 T

Deep drilling
Max. stroke : X x Y x Z: 2,000 x 1,000 x 1,500 mm Max. load: 15 T

Boring, Drilling, Edge milling, etc.

MECHANICAL WELDING can be carried out upon demand

HANDLING
Bridge cranes of up to 20 T

STEEL PLATE SPECIFICATIONS

In stock: C25 - C45
Upon demand: Pre-treated steel, high-strength aluminium, etc.
Stress relieving upon request.

TYPES OF PLATES

The peripheral shapes are torch-cut and deburred. The edges may be milled for reference surfaces.
If tolerances are not specified for the thickness, the plates will be spotfaced to the minimum extent, i.e. the blank sheet of the specified thickness is ground until our standards of flatness and parallel alignment are obtained
Spot facing = 0 to 3 mm/metre max.

DIE SETS WITH TORCH-CUTTING AND MACHINING ACCORDING TO DRAWING

We manufacture die sets according to your drawing and design specifications. Heavy machining removing a lot of metal, carried out after the die set has been assembled, may cause deformations. We recommend that you let us perform these machining operations.

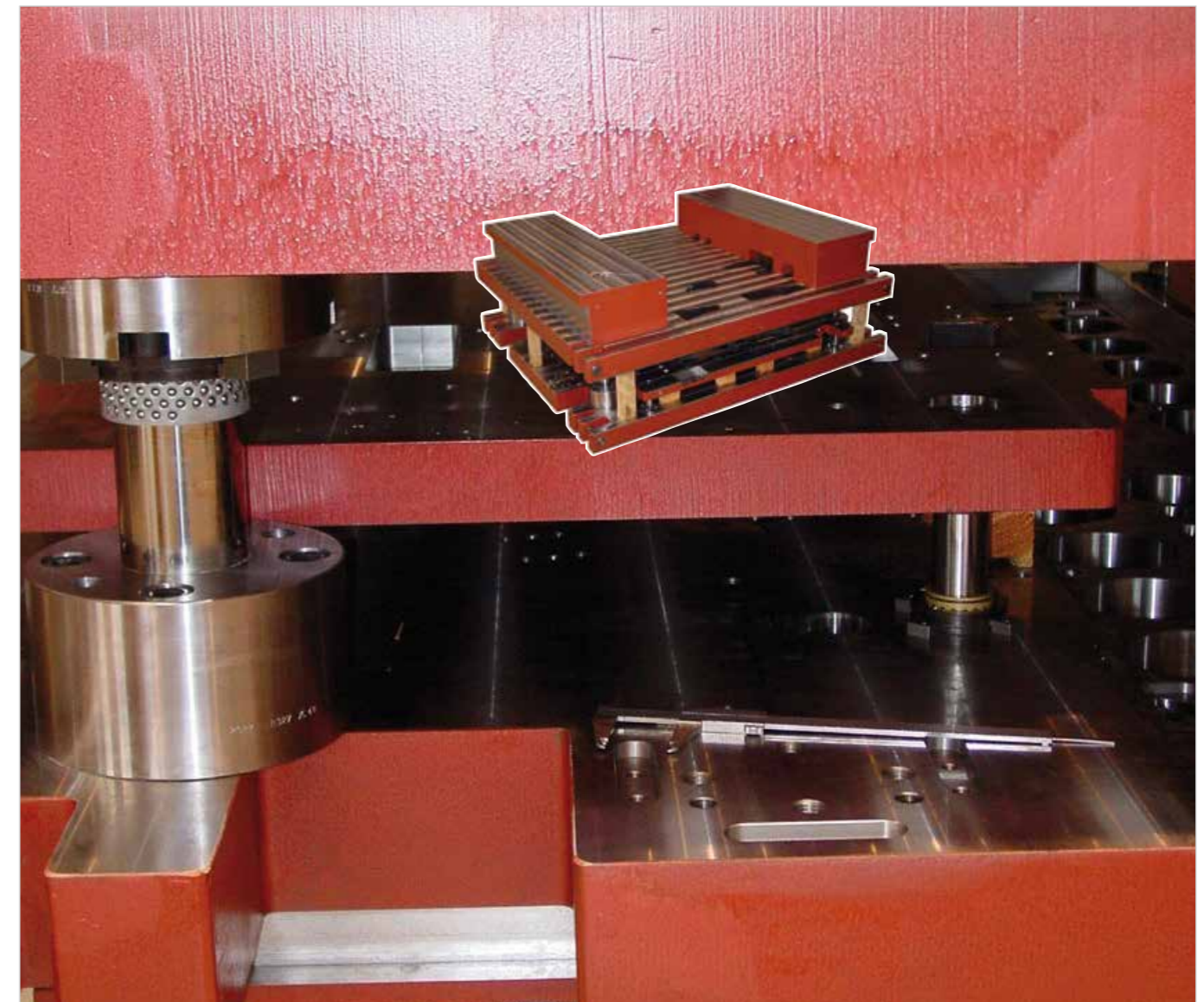

FLATNESS OF PLATE FACES	
Thickness	TE
E > 30mm	0,004 / 100 mm
20 < E < 30 mm	0,008 / 100 mm

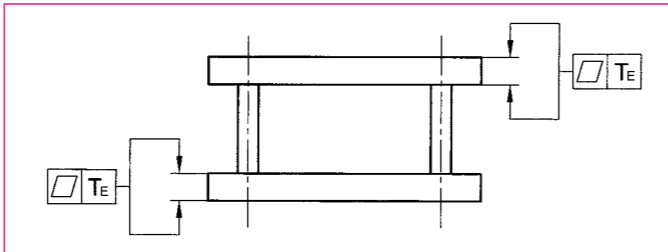

PARALLEL ALIGNMENT OF PLATE FACES		
from mm	to mm	TP
0	100	0,006
100	200	0,012
200	300	0,018

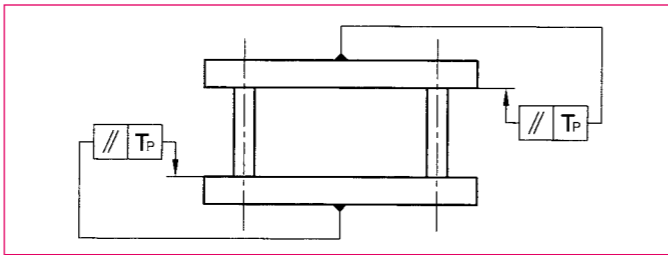

PARALLEL ALIGNMENT OF EXTERNAL FACES OF DIE SET		
from mm	to mm	TP
0	100	0,008
100	200	0,012
200	300	0,018
300	400	0,024
400	500	0,030
500	600	0,036

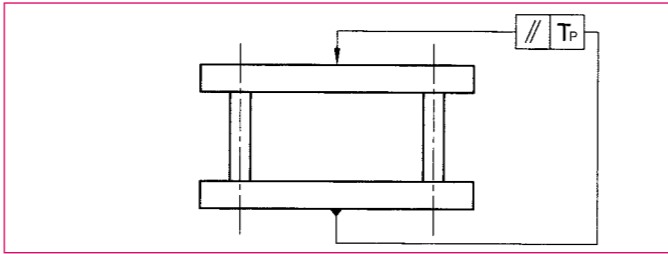

LOCATION	
TA: ±12 µm/m + additional 5 µm/m	

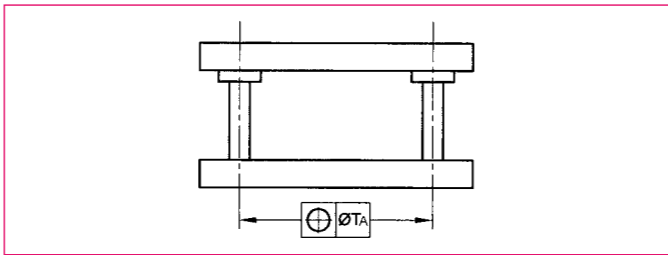

PERPENDICULARITY	
TW	
0,015 / 100mm	

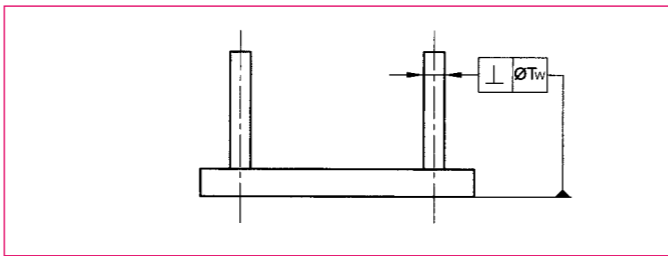

ADJUSTMENT OF BORES	
Guide pillar	Guide bush
d = R6	D = H6

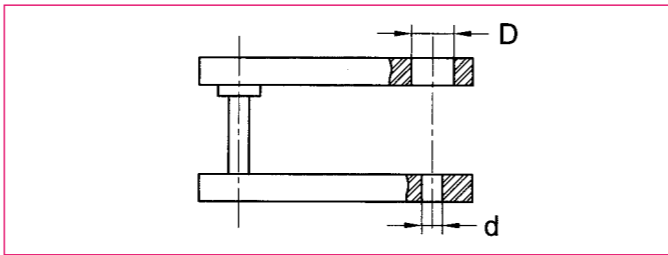
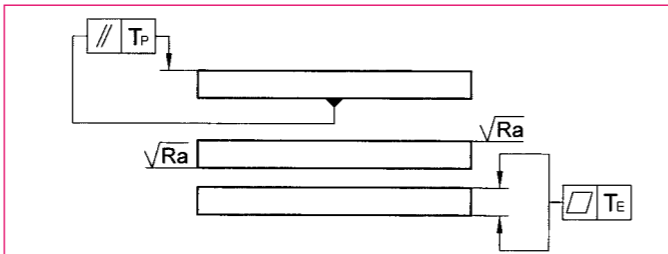
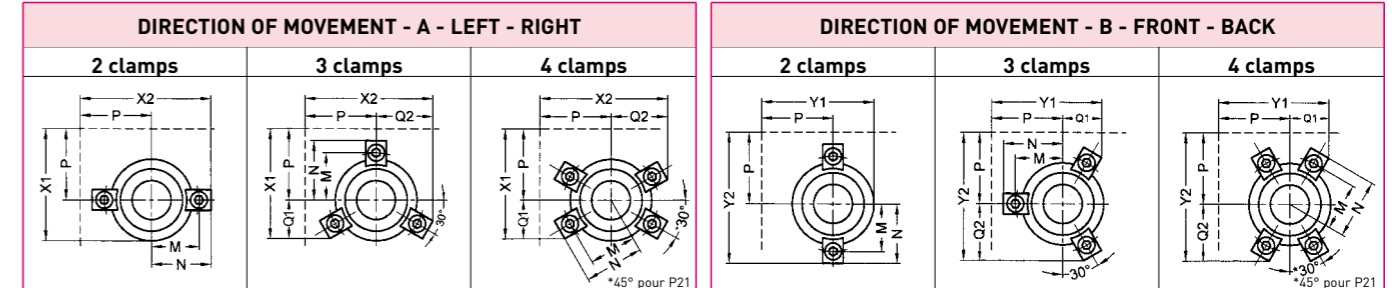

PLATE WITH MIN. SPOTFACING		
TE	TP	RA
0,04/1000 mm	0,06/1000 mm	3,2



RECOMMENDED PILLAR DIAMETER ACCORDING TO LENGTH A1 OF PLATE						
Length a1	150 - 300	350 - 500	550 - 700	750 - 1000	1100 - 1900	2000 - 2500
Recommended d1	25	32	40	50	63	80



STANDARD POSITION OF GUIDES AND FIXINGS							
GUIDE PILLAR				P10 - P21 - P22			
Diameter	19 - 20	24 - 25	30 - 32	38 - 40	48 - 50	63	80
no. of P21 clamps	3 x M5	3 x M6	3 x M6	4 x M8	4 x M8	4 x M8	4 x M8
GUIDE BUSH				B10 - B20			
P	30	40	45	50	60	65	75
X1 / Y1	46,3	64,2	71	81,5	97,5	111,5	132,5
X2 / Y2	55,5	74	82	94,1	112,3	122	141,6
no. of clamps	2 x M5	3 x M6	3 x M6	4 x M8	4 x M8	4 x M8	4 x M8
GUIDE BUSH				B12 - B22			
P	30	40	45	50	60	65	75
X1 / Y1	46,3	65,3	72	83,8	97,5	102,5	132,5
X2 / Y2	55,5	76,6	84,6	99	114,2	127,5	146,6
no. of clamps	2 x M5	3 x M6	3 x M6	4 x M8	4 x M8	4 x M8	4 x M8
BALL BEARING GUIDE BUSH				B30 - B40			
P	-	45	50	55	65	70	80
X1 / Y1	-	71	81,5	92,5	111,5	124	142,5
X2 / Y2	-	82	94,1	104,3	122	134	151,8
no. of B40 clamps	-	3 x M6	3 x M8	4 x M8	4 x M8	4 x M8	4 x M8
BALL BEARING GUIDE BUSH intermediate plate				B42			
P	-	45	50	55	65	-	-
X1 / Y1	-	72	79,3	92,5	111,5	-	-
X2 / Y2	-	84,6	93,5	103,7	121,5	-	-
no. of clamps	-	3 x M6	3 x M6	4 x M6	4 x M6	-	-

RECOMMENDED PLATE THICKNESS ACCORDING TO TYPE OF GUIDE ELEMENT USED									
Diameter	P10	P21	P22	B10-B20	B12-B22	B30	B40	B42	Plates
19 - 20	25	25	38	-	-	-	-	-	C1
	20	20	30	20	20	-	-	-	C2
	-	-	-	20	20	-	-	-	C3
24 - 25	32	32	46	-	-	32	32	-	C1
	25	25	38	25	25	32	32	-	C2
	-	-	-	25	25	-	-	22	C3
30 - 32	40	40	56	-	-	40	40	-	C1
	32	32	48	28	32	40	40	-	C2
	-	-	-	25	28	-	-	22	C3
38 - 40	50	50	66	-	-	50	50	-	C1
	40	40	58	32	40	50	50	-	C2
	-	-	-	32	50	-	-	32	C3
48 - 50	58	58	76	-	-	58	58	-	C1
	50	50	68	38	50	58	58	-	C2
	-	-	-	32	50	-	-	38	C3
63	63	63	86	-	-	63	63	-	C1
	58	58	78	50	63	63	63	-	C2
	-	-	-	40	63	-	-	-	C3
80	68	68	98	-	-	-	-	-	C1
	60	60	92	50	80	-	-	-	C2
	-	-	-	40	80	-	-	-	C3

STEEL PLATE SPECIFICATIONS

In stock: C25 - C45
Upon demand: Pre-treated steel, high-strength aluminium, etc.
 Stress relieving upon request.

TYPES OF PLATES:

The peripheral shapes are torch-cut and deburred. The edges can be milled for reference surfaces.
If tolerances are not specified for the thickness, the plates will be spotfaced to the minimum extent, i.e. the blank sheet of the specified thickness is ground until our standards of flatness and parallel alignment are obtained
 Spot facing = Max. of 0 to 3 mm/metre

PLATES WITH TORCH CUTTING AND SPECIAL MACHINING

We can torch-cut, grind and machine **plates according to your drawings**. All of our plates are annealed. If these machining operations require the removal of large amounts of material, it is in your interest to let us perform the roughing (see finish). We control the risks of deformations due to internal stresses.

PLATES WITH TORCH CUTTING AND SPECIAL MACHINING - Other thicknesses available upon request.

C25 : 12 - 15 - 20 - 25 - 30 - 35 - 40 - 42 - 45 - 50 - 52 - 55 - 60 - 65 - 70 - 75 - 80 - 85 - 90 - 95 - 100 - 105 - 110 - 120 - 150
 C45 : 15 - 20 - 25 - 30 - 35 - 40 - 45 - 50 - 55 - 60 - 65 - 70 - 80 - 85 - 90 - 95 - 100 - 105 - 110 - 120 - 130 - 140 - 160

FOR YOUR PLATE ORDERS

- Please specify: :
- Steel grade of the plate
 - Number of plates
 - External dimensions
 - Spotfaced or toleranced faces
 - Torch-cut or milled edges
 - **Special machining operations with detailed drawing**



NEW - THE KIT

PLATE (S)

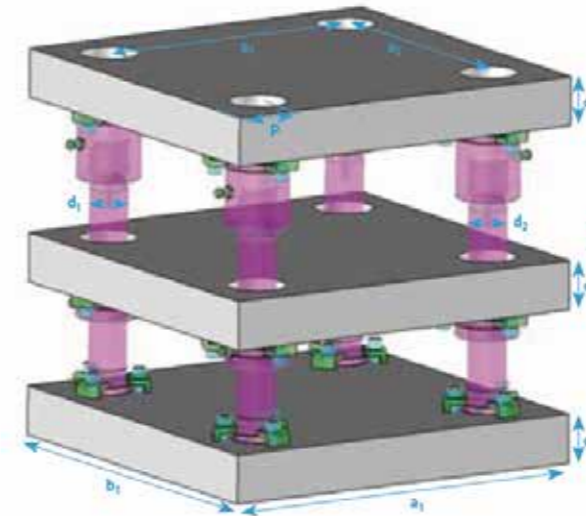

GUIDING ELEMENTS



Example of possible arrangement of the KIT, configuration and options

The KIT is of machined plates according to customer specifications and delivered with MDL Standard guiding components.

- Plates are in C25 Steel, flamse cut and stress relieved.
- Plates are segment surface grinded.
- Guiding elements are from our catalogs (from MDL standard, DIN, or AFNOR) , and are delivered not-assembled with the plates.
- Machining tolerances (mm / lm) :

	0,06		0,04	Ra	<3,2		+/-0,2		+/-2
--	------	--	------	----	------	--	--------	--	------

• Delivery time : 72 hours EXW

- **Options :**
 - Bore machining for Pillar/Bushes
 - Reference surface machining
 - Lifting holes
 - Flame cut areas according to drawings

Example Die Sets (incl C3) Le KIT with 4 guiding elements (to be detailed with the related order document).
 DI16K – Die Sets – The KIT.

Dim. Externes	C123 + 1	D ₁	D ₂	e ₁	e ₂	P	REFERENCES
diagonal max = 2200 mm	150 mm max						
a ₁ et b ₁ to be detailed with the order	to be detailed with the order	according to your guiding element spec.		Options to be detailed with the order			DI16K Options to be detailed with the order



AMDL
www.amdl-eu.com

AMDL

AMDL SCOP SA
Aire d'activité du Florival
9 rue de l'Oberwald
FR-68500 ISSENHEIM
Tél : +33 (0)3 89 74 24 24
contact@amdl-eu.com

