

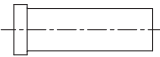

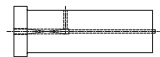

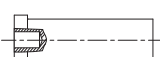

Punches and dies

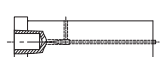
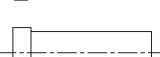

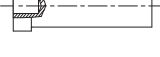
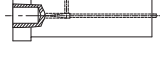
HEADED PUNCHES

P_-PPN		Standard ISO 8020 Without ejector	01
P_-PPE		Standard ISO 8020 With ejector	02
P_-PPD		Center dowel Without ejector	03
P_-PPF		Center dowel With ejector	04
P_-PTN		For heavy duty Without ejector	05
P_-PTE		For heavy duty With ejector	06
P_-PTD		Center dowel Without ejector	07
P_-PTF		Center dowel With ejector	08
PB-PAN		Standard DIN 9844 Without ejector	09
P_-PSN		Micro punches	10
PB-PPNP P_-PPNZ		Pilots	11

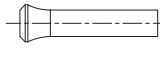
TAPERED HEAD PUNCHES

PB-RFN		Without ejector DIN 5118	12
PB-RFE		With ejector DIN 5118	13

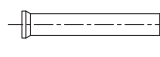
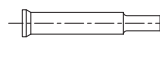
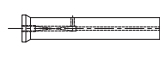
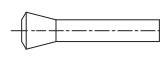
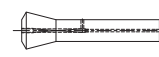

CONICAL HEAD PUNCHES

P_-TFNB		60° - Standard DIN 9861D Without ejector - Blank	14
P_-TFN		60° - Standard DIN 9861D Without ejector	15
P_-TFE		60° - Standard DIN 9861D With ejector	16
P_-TTN		30° - Without ejector	17
P_-TTE		30° - With ejector	18

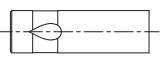
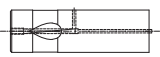
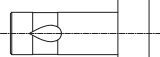

BALL-LOCK PUNCHES

P_-BLN	Light duty		Ball-Lock - Without ejector	19
P_-BHN	Heavy duty			
P_-BLE	Light duty		Ball-Lock - With ejector	20
P_-BHE	Heavy duty			
P_-BJN	Light duty		Point larger than shank	21
P_-BKN	Heavy duty			

STRAIGHT DIE BUTTON - STANDARD ISO 8977

D_-SMWB		Blank	22
D_-SMD		Taper relief	22
D_-SMC		Counterbore relief	23



HEADED DIE BUTTON - STANDARD ISO 8977

D_-HMWB		Blank	24
D_-HMD		Taper relief	24
D_-HMC		Counterbore relief	25

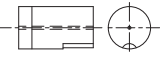
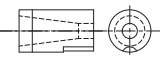
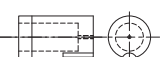
KEY LOCATED DIE BUTTON - STANDARD ISO 8977

DA-SCWB		Blank	26
DA-SCD		Taper relief	26
DA-SCC		Counterbore relief	27







LOW PROFILE DIE BUTTON

DA-SR__		Key located - reversible	28
D_-SS__		Key located	29

BALL-LOCK DIE BUTTON - STANDARD NFE 63-102

DA-BLC		Ball-lock die button	30
---------------	--	----------------------	-----------

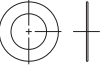
ACCESSORIES

YR-SRSC		Precision screw	31
YR-SCCL		Clamp for headless die button	31
YR-SSCL		Clamp for SS die button	31
YR-RFSE		Seat for tapered head punches	31
Y_-RFMT		Machining tool for tapered head punches	31
YF-SAC		Sharpening spacers	32
YU-SSCR		Urethane strippers	33

ISO PUNCH RETAINERS FOR HEADED PUNCHES

RR-PPT		Standard ISO Light duty	34
RR-PPV		Standard ISO High height	35
RR-PTH		Standard ISO Heavy duty	36





PUNCH RETAINERS FOR TAPERED HEAD PUNCHES

RR-RFFS		Reduced punch retainers	37
----------------	---	-------------------------	-----------



BALL-LOCK PUNCH RETAINERS

RR-BLTN Light duty		NFE 63 -103	38
RR-BHTN Heavy duty		Ball-Lock	38
RT-BLSN Light duty		NFE 63 -103	39
		Ball-Lock with shock plate	
RT-BLRN Light duty		NFE 63 -103	39
		Ball-Lock with shock plate	

AFNOR PUNCH RETAINERS FOR HEADED PUNCHES

RT-PPT		NFE 63 -117 Reduced dimensions	40
RT-PPS		NFE 63-108 Square shape	41
RT-PPR		NFE 63-107 Rectangle shape	42
RZ-PPPH		Punch retainers Retractable	43
RR-XXXX		Special punch retainers	44

DIE RETAINERS

RR-BLSN Light duty		NFE 63 -103	45
		Ball-Lock without shock plate	
RR-BLRN Light duty		NFE 63 -104	45
		Ball-Lock without shock plate	

CLASSIFIED SHAPED CONCAVE - CONVEX

TMX AND TMY SHAPED PUNCHES AND DIES - SPECIALS	46
---	-----------

PUNCHES - TECHNICAL OPTIONS

FLAT LOCATION	48
DOWEL LOCATION	48
OPTIMISATION	48
TOLERANCE MODIFICATIONS	49
DIMENSIONAL MODIFICATIONS	50
SHEAR ANGLES	50

DIE BUTTONS - TECHNICAL OPTIONS

FLAT LOCATION	51
DOWEL LOCATION	52
WASTE RETENTION	53
TOLERANCE MODIFICATIONS	53
DIMENSIONAL MODIFICATIONS	54

ADDITIONAL TECHNICAL INFORMATIONS

COATINGS	55
CUTTING CLEARANCE - RECOMMANDATIONS	55

PUNCHES CODIFICATIONS

B = Material

X155CrVMo12.1/1.2379/HWS/D2	A
Z90/HSS/1.3343/M2/HS 6.5.2	B
Carbure	C
ASP23/1.3395/M32/HS 6.5.3	E
XII0CrMoV8-2	K
M4/1.3351/HS 6.5.4	S

N =

Solid punch	N
Ejector punch	E
Center dowel without ejector	D
Center dowel with ejector	F

P = Metric Punch
(Q = inches dimensions)

Ø Body (mm)

Total length (mm)

L2 Working Length

PB-PPNL-10-120-25-P6.2-W4.8

P - W Shape dimensions

PP = Type

Special	XX
Headed punches, 3mm Thick Body tol m5	PS
Headed punches , Body tol h6 (DIN 9844)	PA
Headed punches, 5mm Thick Body tol m5 (ISO 8020)	PP
Headed punches , 5mm Thick Body tol m4	PV
Headed punches, 5mm Thick Body tol m5 (CNOMO)	PM
Headed punches , 8mm Thick Body tol m5	PT
Headed punches, 10mm Thick Body tol m5	PN
Conical head punches 60° Body tol h6 ISO 6752	TF
Conical head punches 30° Body tol h6	TT
Tapered head punches Body tol h6	RF
Headless punches Body tol h6	LH
Ball-lock punches, heavy duty	BH
Ball-lock punches, light duty	BL
Ball-lock punches, heavy duty "knob"	BK
Ball-lock punches, light-duty "knob"	BJ

L = Shapes

Blank	B
Blank with alteration	A
Round	S
Oblong	L
Square	V
Rectangle	R
Rounded rectangle	F
Hexagon	H
Positive Pick-up Pilots	Y
Straight Pilots	P
Pilots - PPNZ type	Z
Classified Shapes - TMX	T
Classified Shapes - TMY	E
Special	X

P_-PPNB
Blank

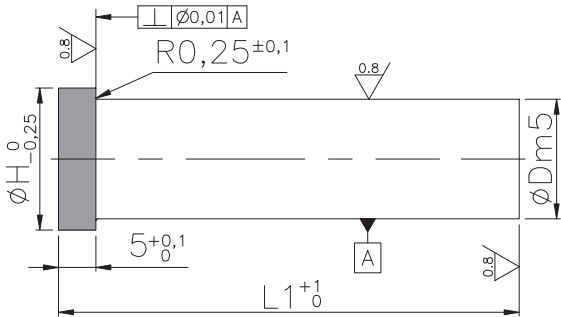

ØH = ØD + 3mm

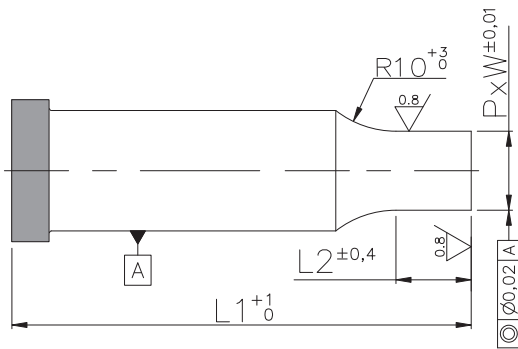

! $G = \sqrt{P^2 + W^2}$. $G \leq \text{ØD} - 0,1$

P_-PPNS
Round

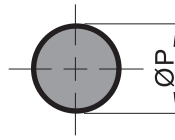

P_-PPNF
Rounded rectangle

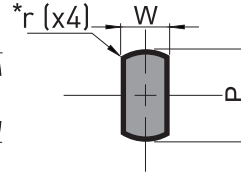

P_-PPNV
Square

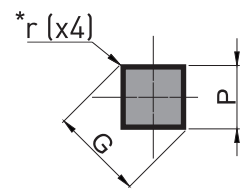

P_-PPNL
Oblong

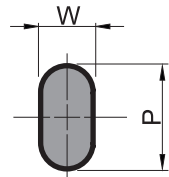

P_-PPNR
Rectangle

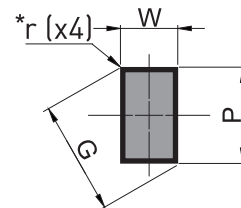

P_-PPNH
Hexagon

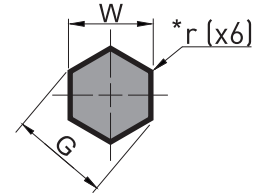

*Angle radius is r=0 by default
(If you want a radius of 1.5mm please specify r1.5)



Flat location on demand
Example : R2T0 Flat tangent to the body at 0°.

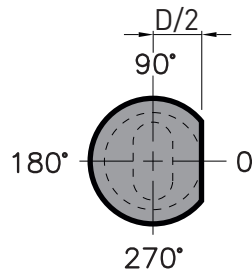

Alternate locations page 48

Reference	Ø D	L1				L2	P_-PPNS		Others shapes	
		71	80	100	120		ØP	W (min)	P / G (max)	
	4	B	B	B	B	10	1,0 - 3,9	1,5	3,9	
	5	B+E	B+E	B+E	B	10	1,0 - 4,9	1,5	4,9	
	6	B+E	B+E	B+E	B	10	1,5 - 5,9	1,5	5,9	
	7	B+E	B+E	B+E	B	10	2,0 - 6,9	1,7	6,9	
	8	B+E	B+E	B+E	B	13	2,5 - 7,9	2	7,9	
	9	B	B	B	B	13	3,5 - 8,9	2,7	8,9	
	10	A+B+E+S	A+B+E+S	A+B+E+S	B	13	4,5 - 9,9	3,5	9,9	
	11	B	B	B	B	13	5,1 - 10,9	3,8	10,9	
	12	B	B	B	B	16	5,8 - 11,9	4,2	11,9	
	13	A+B+E+S	A+B+E+S	A+B+E+S	B	16	6,5 - 12,9	4,5	12,9	
	14	B	B	B	B	16	7,5 - 13,9	5,1	13,9	
	15	B	B	B	B	20	8,5 - 14,9	5,7	14,9	
	16	A+B+E+S	A+B+E+S	A+B+E+S	B	20	9,5 - 15,9	6	15,9	
	20	A+B+E+S	A+B+E+S	A+B+E+S	B	20	12,5 - 19,9	8	19,9	
	25	A+B+E+S	A+B+E+S	A+B+E+S	B	20	16,5 - 24,9	10	24,9	
	32	A+B	A+B	A+B	B	20	22,5 - 31,9	12	31,9	
	40	B	B	B	B	20	30,5 - 39,9	14	39,9	

ØD and length "L1" : Others dimensions on request.

Length L2 applied by default, others dimensions on request.

Material	Body	Head
A = (X155CrVMo.12.1)	58 - 62	40 - 50 HRc
B = (Z90 WDCV 06050402)	60 - 64	47 - 57 HRc
E = (ASP23)	62 - 66	47 - 57 HRc
S = (M4)	62 - 66	47 - 57 HRc

To order :

Punch HSS ISO 8020 Solid Blank D/body L1
P B - P P N B - 16 - 71 Blank

Punch HSS ISO 8020 Solid Rectangle D/body L1 L2 Shape dimensions Flat Position
P B - P P N R - 16 - 71 - 20 - P12.2 - W7.2 - R2 - T90 Shaped

+ Other materials on request.
 Other cutting shapes (E ; T ; X) : page 46
 Available coatings : page 55
 Technical options : page 48

P_-PPEB
Blank

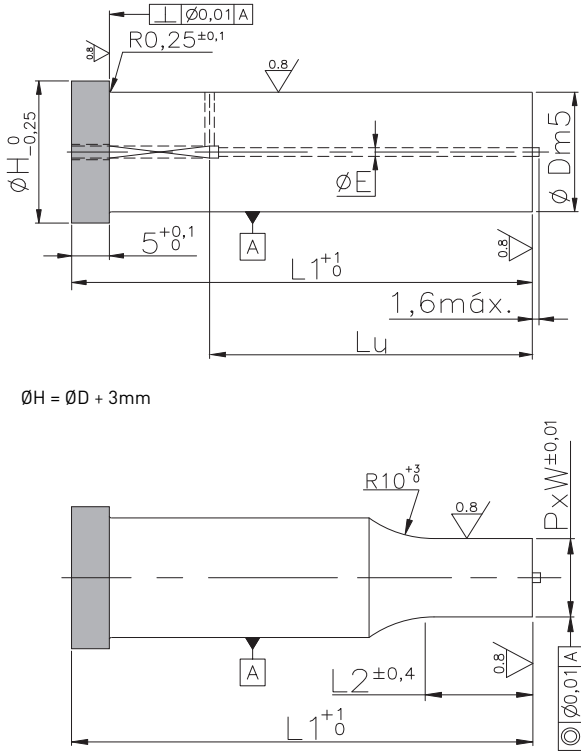

$\varnothing H = \varnothing D + 3\text{mm}$

! $G = \sqrt{P^2 + W^2}$. $G \leq \varnothing D - 0,1$

P_-PPES
Round

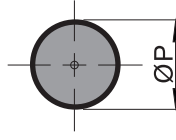

P_-PPEF
Rounded rectangle

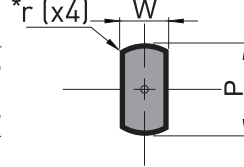

P_-PPEV
Square

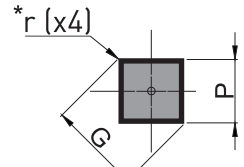

P_-PPEL
Oblong

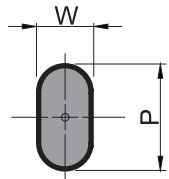

P_-PPER
Rectangle

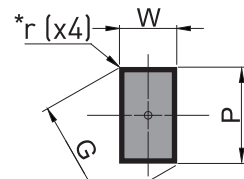

P_-PPEH
Hexagon

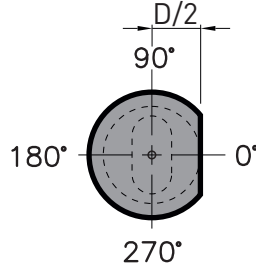
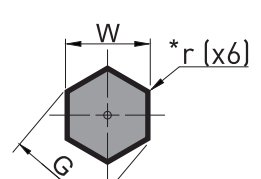

*Angle radius is r=0 by default
(If you want a radius of 1.5mm please specify r1.5)

Flat location on demand
Example : R2T0 Flat tangent to the body at 0°.



Alternate locations page 48

Reference	Ø D	L1				L2	ØE	P_-PPES	Others shapes	
		71	80	100	120			ØP	W (min)	P / G (max)
Shapes Material PB - PPER S L F V H (TMY) = E (TMX) = T (SPECIALS) = X	5	B	B	B		10	1,1	1,0 - 4,9	2,5	4,9
	6	B	B	B		10	1,1	1,5 - 5,9	2,5	5,9
	8	B	B	B	B	13	1,1	2,5 - 7,9	3	7,9
	10	B	B	B	B	13	1,3	4,5 - 9,9	4,5	9,9
	13	B	B	B	B	16	1,3	6,5 - 12,9	6	12,9
	16	B	B	B	B	20	2,2	9,5 - 15,9	7	15,9
	20	B	B	B	B	20	2,2	12,5 - 19,9	8	19,9
	25	B	B	B	B	20	2,2	16,5 - 24,9	10	24,9
	32	B	B	B	B	20	2,2	22,5 - 31,9	12	31,9
	40	B	B	B	B	20	2,2	30,5 - 39,9	14	39,9
ØD and length "L1" : Others dimensions on request.		LU				<div style="border: 1px solid black; display: inline-block; width: 10px; height: 10px; margin-right: 5px;"></div> Length L2 applied by default, others dimensions on request.				
		39	48	68	68					

Material	Body	Head
B = (Z90 WDCV 06050402)	60 - 64	47 - 57 HRc

+ Other materials on request.
Other cutting shapes (E ; T ; X) : page 46
Available coatings : page 55
Technical options : page 48

To order :

Punch HSS ISO 8020 Ejector Blank D/body L1
PB - PPEB - 16 - 71 Blank

Punch HSS ISO 8020 Ejector Rectangle D/body L1 L2 Shape dimensions Flat Position
PB - PPER - 16 - 71 - 20 - P12.2 - W8.2 - R2 - T90 Shaped

NEW

P_-PPDB
Blank

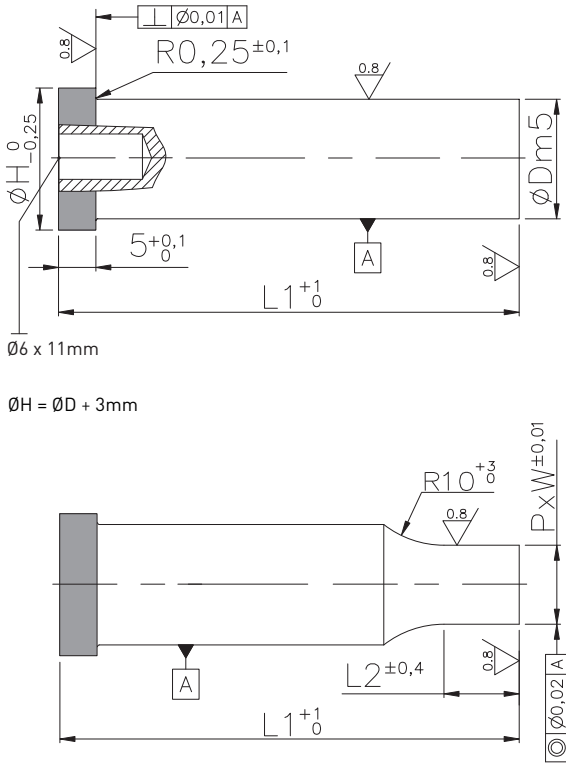

P_-PPDS
Round

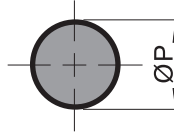

P_-PPDF
Rounded rectangle

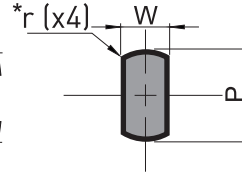

P_-PPDV
Square

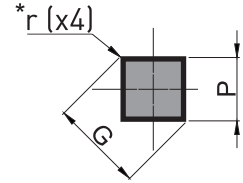

P_-PPDL
Oblong

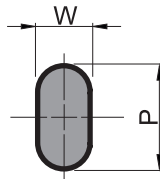

P_-PPDR
Rectangle

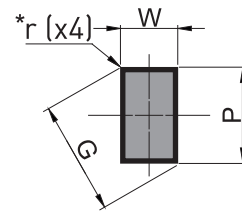

P_-PPDH
Hexagon

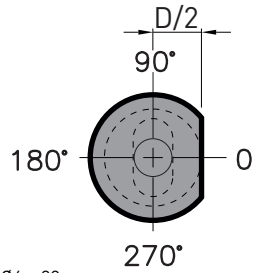
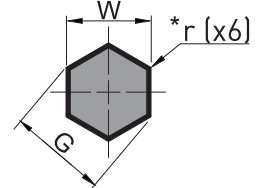

*Angle radius is r=0 by default
(If you want a radius of 1.5mm please specify r1.5)

Flat location on demand
Example : R2T0 Flat tangent to the body at 0°.



Alternate locations page 48



$$G = \sqrt{P^2 + W^2} \cdot G \leq \text{ØD} - 0,1$$

Delivered with dowel pins - Ø6 x 20mm
A20.006.020

Reference	Ø D	L1				L2	Others shapes		
		71	80	100	120		P_-PPDS ØP	W (min)	P / G (max)
<p>Shapes</p> <ul style="list-style-type: none"> S L PB - PPDR A E S <p>Material</p> <ul style="list-style-type: none"> F V H <p>(TMY) = E (TMX) = T (SPECIALS) = X</p>	10	A+B+E+S	A+B+E+S	A+B+E+S	B	13	4,5 - 9,9	3,5	9,9
	11	B	B	B	B	13	5,1 - 10,9	3,8	10,9
	12	B	B	B	B	16	5,8 - 11,9	4,2	11,9
	13	A+B+E+S	A+B+E+S	A+B+E+S	B	16	6,5 - 12,9	4,5	12,9
	14	B	B	B	B	16	7,5 - 13,9	5,1	13,9
	15	B	B	B	B	20	8,5 - 14,9	5,7	14,9
	16	A+B+E+S	A+B+E+S	A+B+E+S	B	20	9,5 - 15,9	6	15,9
	20	A+B+E+S	A+B+E+S	A+B+E+S	B	20	12,5 - 19,9	8	19,9
	25	A+B+E+S	A+B+E+S	A+B+E+S	B	20	16,5 - 24,9	10	24,9
	32	A+B	A+B	A+B	B	20	22,5 - 31,9	12	31,9
	40	B	B	B	B	20	30,5 - 39,9	14	39,9

ØD and length "L1" : Others dimensions on request.

Length L2 applied by default, others dimensions on request.

Material	Body	Head
A = (X155CrVMo.12.1)	58 - 62	40 - 50 HRc
B = (Z90 WDCV 06050402)	60 - 64	47 - 57 HRc
E = (ASP23)	62 - 66	47 - 57 HRc
S = (M4)	62 - 66	47 - 57 HRc

To order :

Blank

Punch HSS 150 8020 Dowel Blank D/body L1
PB - PPDB - 16 - 71

Shaped

Punch HSS 150 8020 Dowel Rectangle D/body L1 L2 Shape dimensions Flat Position
PB - PPDR - 16 - 71 - 20 - P12.2 - W8.2 - R2 - T90



Other materials on request.
Other cutting shapes (E ; T ; X) : page 46

Available coatings : page 55
Technical options : page 48

NEW

P_-PPFB
Blank

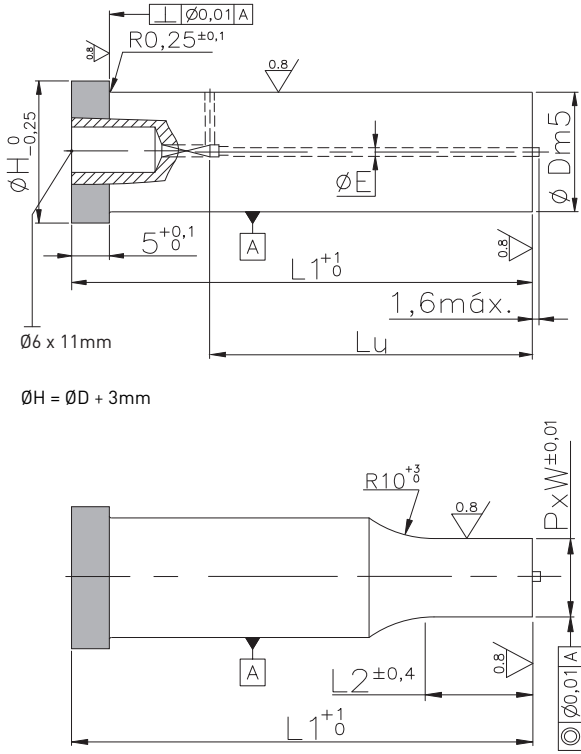

$\text{ØH} = \text{ØD} + 3\text{mm}$

P_-PPFS
Round

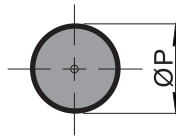

P_-PPFF
Rounded rectangle

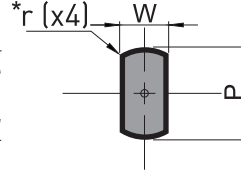

P_-PPFV
Square

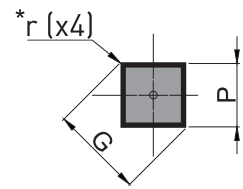

P_-PPFL
Oblong

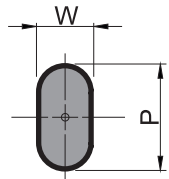

P_-PPFR
Rectangle

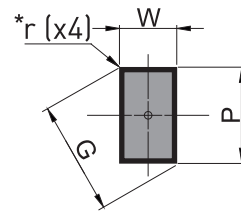

P_-PPFH
Hexagon

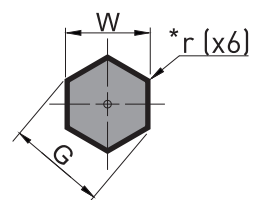

*Angle radius is r=0 by default
(If you want a radius of 1.5mm please specify r1.5)

Flat location on demand
Example : R2T0 Flat tangent to the body at 0°.

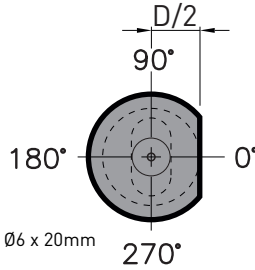

Alternate locations page 48



$G = \sqrt{P^2 + W^2}$. $G \leq \text{ØD} - 0,1$

Delivered with dowel pins - Ø6 x 20mm
A20.006.020

270°

Reference	Ø D	L1				L2	ØE	P_-PPFS	Others shapes	
		71	80	100	120			ØP	W (min)	P / G (max)
<p>Shapes</p> <p>Material</p> <p>PB - P_PFR</p> <p>S L F V H</p> <p>(TMY) = E (TMX) = T (SPECIALS) = X</p>	10	B	B	B	B	13	1,3	4,5 - 9,9	4,5	9,9
	13	B	B	B	B	16	1,3	6,5 - 12,9	6	12,9
	16	B	B	B	B	20	2,2	9,5 - 15,9	7	15,9
	20	B	B	B	B	20	2,2	12,5 - 19,9	8	19,9
	25	B	B	B	B	20	2,2	16,5 - 24,9	10	24,9
	32	B	B	B	B	20	2,2	22,5 - 31,9	12	31,9
	40	B	B	B	B	20	2,2	30,5 - 39,9	14	39,9
	ØD and length "L1" : Others dimensions on request.		LU				Length L2 applied by default, others dimensions on request.			
		39	48	68	68					

Material	Body	Head
B = (Z90 WDCV 06050402)	60 - 64	47 - 57 HRc



Other materials on request.
Other cutting shapes (E ; T ; X) : page 46

Available coatings : page 55
Technical options : page 48

To order :

Punch HSS	ISO 8020	Dowel Blank	D-body	L1	Blank
PB - P_PFB - 16 - 71					
Punch HSS	ISO 8020	Dowel	Rectangle	D-body	L1
PB - P_PFR - 16 - 71 - 20 - P11.2 - W8.2 - R2 - T90					
Shape dimensions					
Flat Position					

NEW

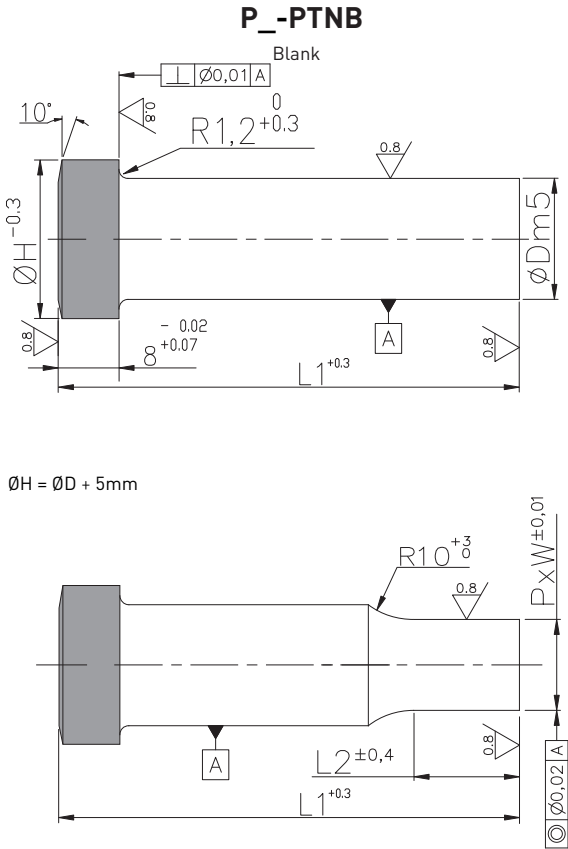

ØH = ØD + 5mm

! $G = \sqrt{P^2 + W^2}$. $G \leq \text{ØD} - 0,1$

P_-PTNS
Round

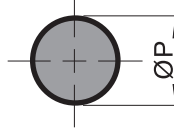

P_-PTNF
Rounded rectangle

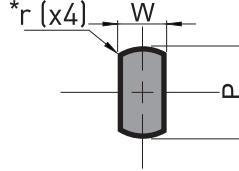

P_-PTNV
Square

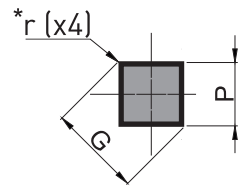

P_-PTNL
Oblong

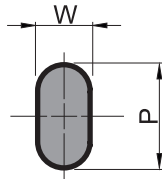

P_-PTNR
Rectangle

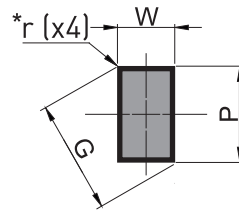

P_-PTNH
Hexagon

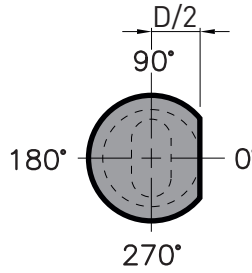
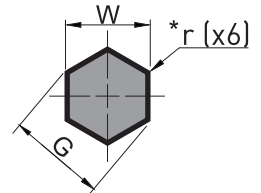

*Angle radius is r=0 by default
(If you want a radius of 1.5mm please specify r1.5)



Flat location on demand
Example : R2T0 Flat tangent to the body at 0°.

Alternate locations page 48

Reference	Ø D	L1			L2	P_-PTNS	Others shapes	
		71	80	100		ØP	W (min)	P / G (max)
<p>Shapes</p> <p>Material</p> <p>P B - P T N R</p> <p>S</p> <p>(TMY) = E</p> <p>(TMX) = T</p> <p>(SPECIALS) = X</p>	8	B+S	B+S	B+S	13	3 - 7,9	3	7,9
	10	B+S	B+S	B+S	13	4,5 - 9,9	4,5	9,9
	13	B+S	B+S	B+S	16	8 - 12,9	6	12,9
	16	B+S	B+S	B+S	20	9,5 - 15,9	6	15,9
	20	B+S	B+S	B+S	20	12,5 - 19,9	8	19,9
	25	B+S	B+S	B+S	20	18 - 24,9	10	24,9
	32	B+S	B+S	B+S	20	22,5 - 31,9	12	31,9

ØD and length "L1" : Others dimensions on request Length L2 applied by default, others dimensions on request.

Material	Body	Head
B = (Z90 WDCV 06050402)	60 - 64	47 - 57 HRc
S = (M4)	62 - 66	47 - 57 HRc

+ Other materials on request.
Other cutting shapes (E ; T ; X) : page 46
Available coatings : page 55
Technical options : page 48

To order :

Punch HSS Heavy duty Solid Blank D/body L1
P B - P T N B - 16 - 71 Blank

Punch HSS Heavy duty Solid Rectangle D/body L1 L2 Shape dimensions Flat Position
P B - P T N R - 16 - 71 - 20 - P10.2 - W7.2 - R2 - T90

NEW

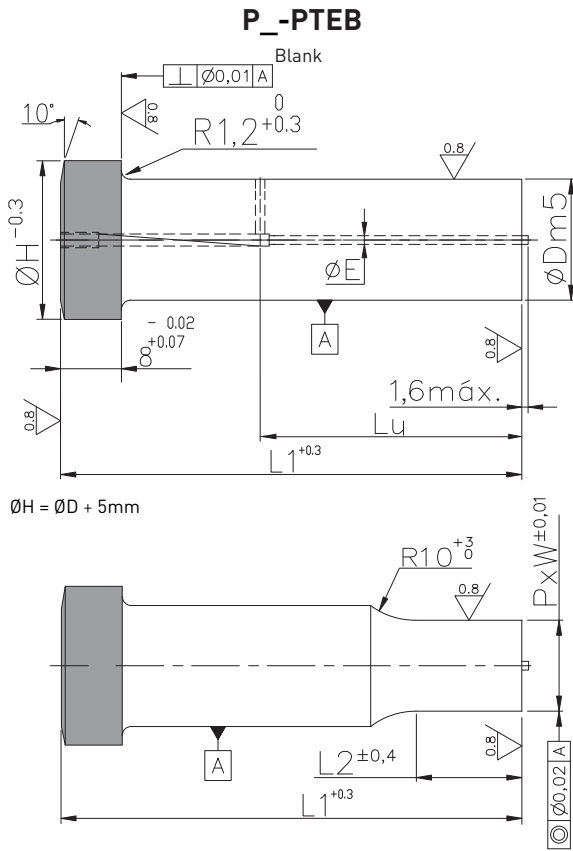

ØH = ØD + 5mm

! $G = \sqrt{P^2 + W^2}$. $G \leq \text{ØD} - 0,1$

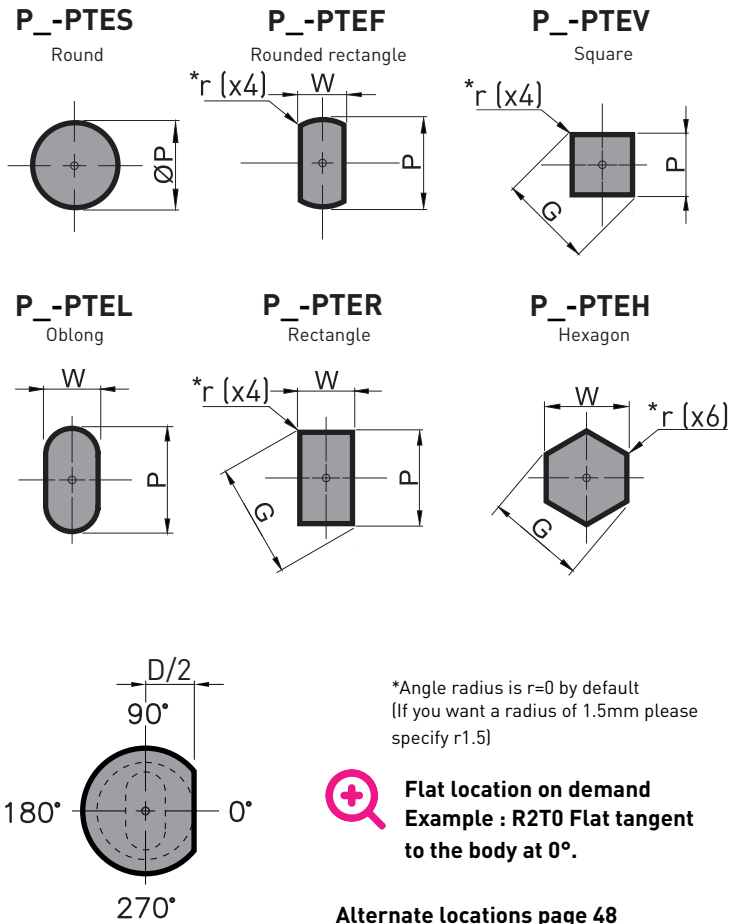

Reference	Ø D	L1			L2	ØE	P_-PTES	Others shapes	
		71	80	100			ØP	W (min)	P / G (max)
Shapes S L PB - PTER F V H S (TMY) = E (TMX) = T (SPECIALS) = X	8	B+S	B+S	B+S	13	1,1	4 - 7,9	3	7,9
	10	B+S	B+S	B+S	13	1,3	5,5 - 9,9	4,5	9,9
	13	B+S	B+S	B+S	16	1,3	8 - 12,9	6	12,9
	16	B+S	B+S	B+S	20	2,2	9,5 - 15,9	6	15,9
	20	B+S	B+S	B+S	20	2,2	12,5 - 19,9	8	19,9
	25	B+S	B+S	B+S	20	2,2	18 - 24,9	10	24,9
	32	B+S	B+S	B+S	20	2,2	22,5 - 31,9	12	31,9
ØD and length "L1" : Others dimensions on request.		LU			Length L2 applied by default, others dimensions on request.				
		39	48	68					

Material	Body	Head
B = (Z90 WDCV 06050402)	60 - 64	47 - 57 HRc
S = (M4)	62 - 66	47 - 57 HRc

+ Other materials on request.
Other cutting shapes (E ; T ; X) : page 46
Available coatings : page 55
Technical options : page 48

To order :

Punch HSS Heavy duty Ejector Blank D/body L1
PB - PTEB - 16 - 71

Punch HSS Heavy duty Ejector Rectangle D/body L1 L2 Shape dimensions Flat Position
PB - PTER - 16 - 71 - 20 - P9.2 - W6.2 - R2 - T90

NEW

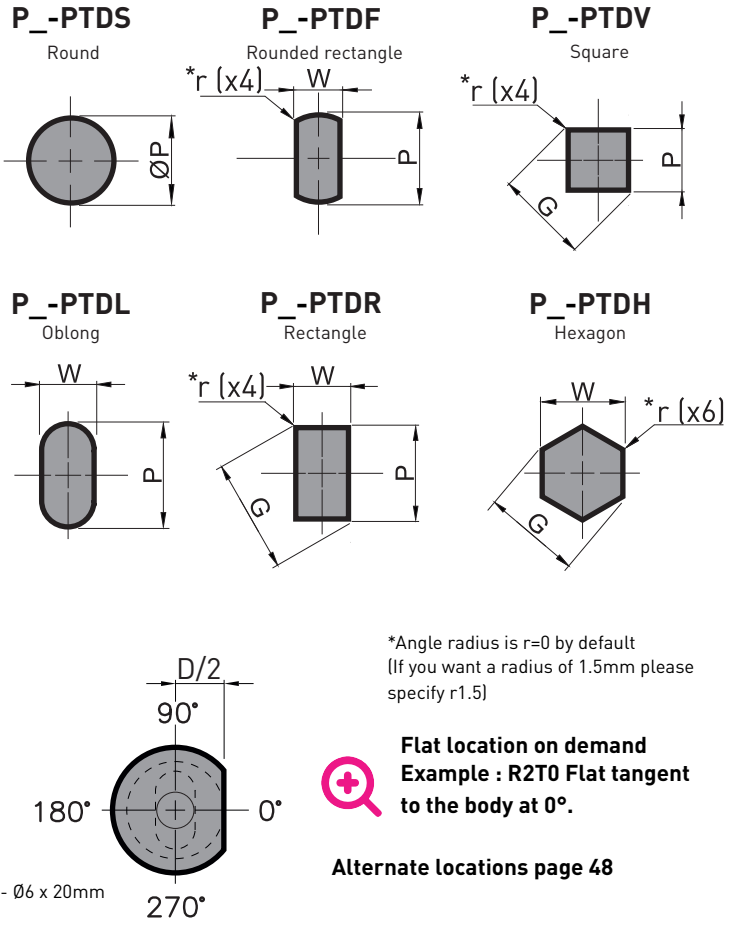
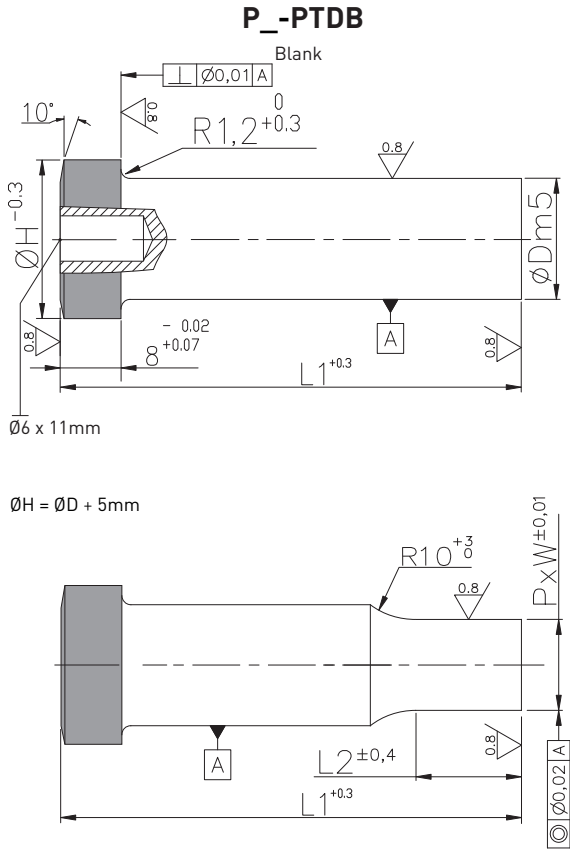

*Angle radius is r=0 by default
(If you want a radius of 1.5mm please specify r1.5)

Flat location on demand
Example : R2T0 Flat tangent to the body at 0°.

Alternate locations page 48

! $G = \sqrt{P^2 + W^2}$. $G \leq \text{ØD} - 0,1$

Delivered with dowel pins - Ø6 x 20mm
A20.006.020

Reference	Ø D	L1			L2	P_-PTDS	Others shapes	
		71	80	100		ØP	W (min)	P / G (max)
<p>Shapes</p> <p>Material</p> <p>PB - PTDR</p> <p>S</p> <p>(TMY) = E</p> <p>(TMX) = T</p> <p>(SPECIALS) = X</p>	8	B+S	B+S	B+S	13	3 - 7,9	3	7,9
	10	B+S	B+S	B+S	13	4,5 - 9,9	4,5	9,9
	13	B+S	B+S	B+S	16	8 - 12,9	6	12,9
	16	B+S	B+S	B+S	20	9,5 - 15,9	6	15,9
	20	B+S	B+S	B+S	20	12,5 - 19,9	8	19,9
	25	B+S	B+S	B+S	20	18 - 24,9	10	24,9
	32	B+S	B+S	B+S	20	22,5 - 31,9	12	31,9

ØD and length "L1" : Others dimensions on request Length L2 applied by default, others dimensions on request.

Material	Body	Head
B = (Z90 WDCV 06050402)	60 - 64	47 - 57 HRc
S = (M4)	62 - 66	47 - 57 HRc

To order :

Punch HSS Heavy duty Dowel Blank D body L1
PB - PTDB - 16 - 71

Punch HSS Heavy duty Dowel Rectangle D body L1 L2 Shape dimensions Flat Position
PB - P T D R - 16 - 71 - 20 - P9.2 - W6.2 - R2 - T90

+ Other materials on request.
Other cutting shapes (E ; T ; X) : page 46
Available coatings : page 55
Technical options : page 48

NEW

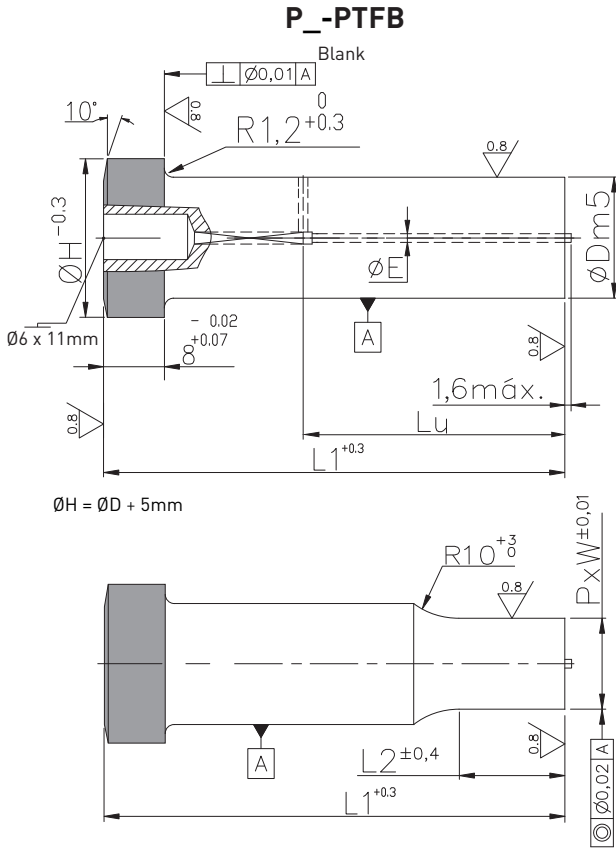

P_-PTFS
Round

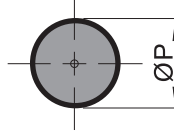

P_-PTFF
Rounded rectangle

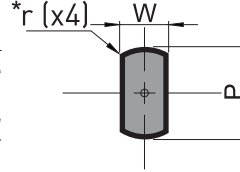

P_-PTFV
Square

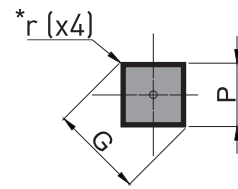

P_-PTFL
Oblong

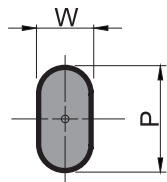

P_-PTFR
Rectangle

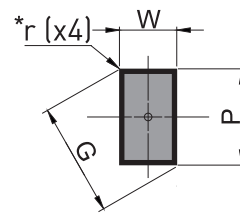

P_-PTFH
Hexagon

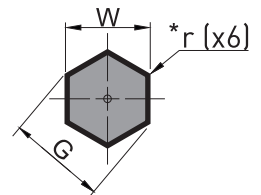

*Angle radius is r=0 by default
(If you want a radius of 1.5mm please specify r1.5)

Flat location on demand
Example : R2T0 Flat tangent to the body at 0°.



Alternate locations page 48



$$G = \sqrt{P^2 + W^2} \cdot G \leq \text{ØD} - 0,1$$

Delivered with dowel pins - Ø6 x 20mm
A20.006.020

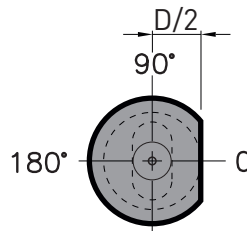

Reference	Ø D	L1			L2	ØE	P_-PTFS	Others shapes	
		71	80	100			ØP	W (min)	P / G (max)
Shapes Material PB - PTFR S (TMY) = E (TMX) = T (SPECIALS) = X	8	B+S	B+S	B+S	13	1,1	4 - 7,9	3	7,9
	10	B+S	B+S	B+S	13	1,3	5,5 - 9,9	4,5	9,9
	13	B+S	B+S	B+S	16	1,3	8 - 12,9	6	12,9
	16	B+S	B+S	B+S	20	2,2	9,5 - 15,9	6	15,9
	20	B+S	B+S	B+S	20	2,2	12,5 - 19,9	8	19,9
	25	B+S	B+S	B+S	20	2,2	18 - 24,9	10	24,9
	32	B+S	B+S	B+S	20	2,2	22,5 - 31,9	12	31,9
ØD and length "L1" : Others dimensions on request.		LU			Length L2 applied by default, others dimensions on request.				
		39	48	68					

Material	Body	Head
B = (Z90 WDCV 06050402)	60 - 64	47 - 57 HRc
S = (M4)	62 - 66	47 - 57 HRc

To order :

Punch HSS Heavy duty Dowel Ejector Blank D/body L1
PB - PTFB - 16 - 71

Punch HSS Heavy duty Dowel Ejector Rectangle D/body L1 L2 Shape dimensions Flat Position
PB - PTFR - 16 - 71 - 20 - P10.2 - W8.2 - R2 - T90

+ Other materials on request.
 Other cutting shapes (E ; T ; X) : page 46
 Available coatings : page 55
 Technical options : page 48

NEW

PB-PANB

Blank

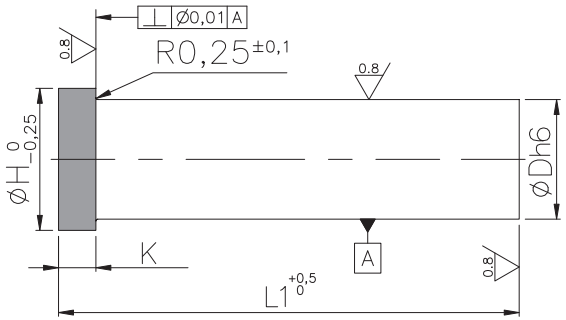

$\emptyset H = \emptyset D + 3\text{mm}$

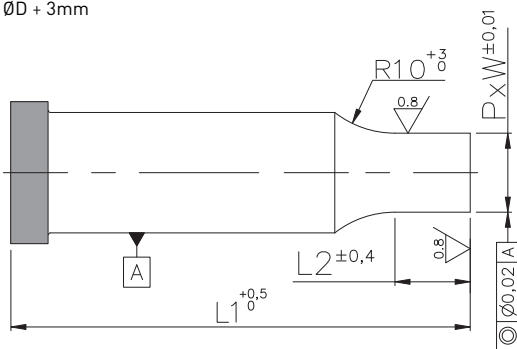

! $G = \sqrt{P^2 + W^2} . G \leq \emptyset D - 0,1$

PB-PANS

Round

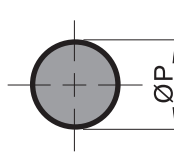

PB-PANF

Rounded rectangle

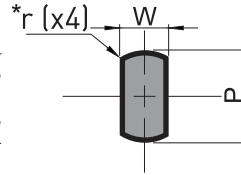

PB-PANV

Square

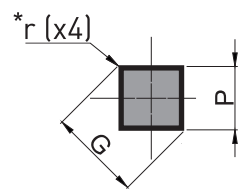

PB-PANL

Oblong

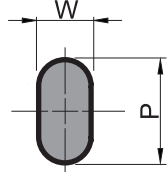

PB-PANR

Rectangle

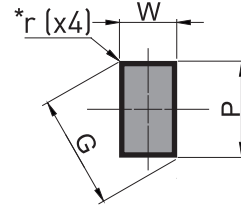

PB-PANH

Hexagon

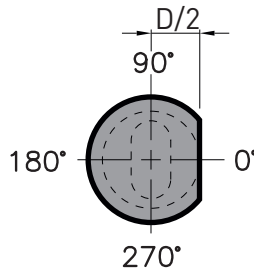
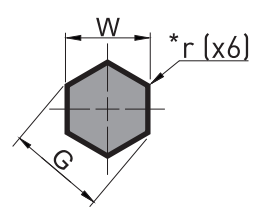

*Angle radius is r=0 by default
(If you want a radius of 1.5mm please specify r1.5)



Flat location on demand
Example : R2T0 Flat tangent to the body at 0°.

Alternate locations page 48

Reference	Ø D	L1			L2	PB-PANS		Others shapes		ØH	K
		71	80	100		ØP	W (min)	P / G (max)			
<p>Shapes</p> <p>Material</p> <p>PB-PANR</p> <p>S L F V H</p> <p>(TMY) = E (TMX) = T (SPECIALS) = X</p>	4	B	B	B	10	1,0 - 3,9	1,5	3,9	6	4	
	4,5	B	B	B	10	1,2 - 4,4	1,5	4,4	7		
	5	B	B	B	10	1,0 - 4,9	1,5	4,9	8		
	5,5	B	B	B	10	1,2 - 5,4	1,5	5,4	9		
	6	B	B	B	10	1,5 - 5,9	1,5	5,9	9		
	6,5	B	B	B	10	1,7 - 6,4	1,6	6,4	10		
	7	B	B	B	10	2,0 - 6,9	1,7	6,9	10		
	7,5	B	B	B	13	2,1 - 7,4	1,9	7,4	11		
	8	B	B	B	13	2,5 - 7,9	2	7,9	11		
	8,5	B	B	B	13	3 - 8,4	2,4	8,4	12		
	9	B	B	B	13	3,5 - 8,9	2,7	8,9	12		
	10	B	B	B	13	4,5 - 9,9	3,5	9,9	13		
	11	B	B	B	13	5,1 - 10,9	3,8	10,9	14		
	12	B	B	B	16	5,8 - 11,9	4,2	11,9	15		
	13	B	B	B	16	6,5 - 12,9	4,5	12,9	16		
	14	B	B	B	16	7,5 - 13,9	5,1	13,9	17		
15	B	B	B	20	8,5 - 14,9	5,7	14,9	18			
16	B	B	B	20	9,5 - 15,9	6	15,9	19	5		

ØD and length "L1" : Others dimensions on request.

Length L2 applied by default, others dimensions on request.

Material	Body	Head
B = (Z90 WDCV 06050402)	60 - 64	47 - 57 HRc

To order :

Blank

Punch HSS DIN 9844 Solid Blank D.body L1
PB-PANB-10-71

Punch HSS DIN 9844 Solid Rectangle D.body L1 L2
PB-PANR-10-71-20-P6.2-W4.2-R2-T90

Shape dimensions Flat Position

+ Other materials on request.
Other cutting shapes (E ; T ; X) : page 46
Available coatings : page 55
Technical options : page 48

P_-PSNB
Blank

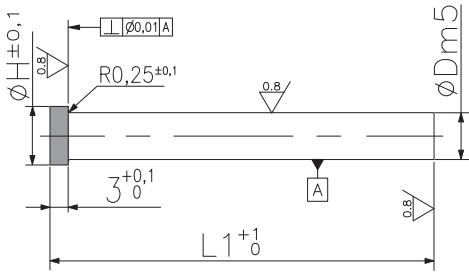

$\varnothing H = \varnothing D + 1,5\text{mm}$

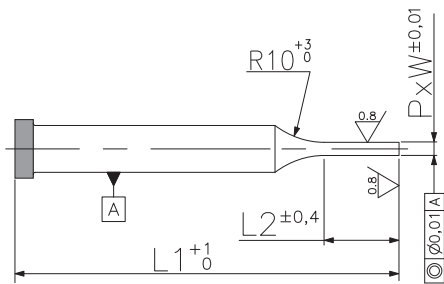

! $G = \sqrt{P^2 + W^2}$. $G \leq \varnothing D - 0,1$

P_-PSNS
Round

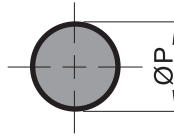

P_-PSNF
Rounded rectangle

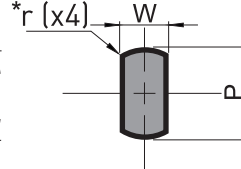

P_-PSNV
Square

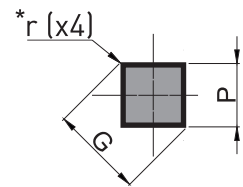

P_-PSNL
Oblong

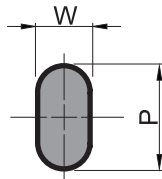

P_-PSNR
Rectangle

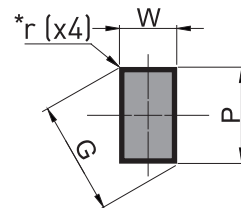

P_-PSNH
Hexagon

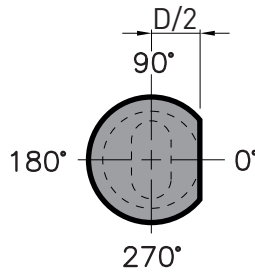
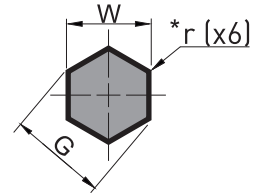

*Angle radius is r=0 by default
(If you want a radius of 1.5mm please specify r1.5)



Flat location on demand
Example : R2T0 Flat tangent to the body at 0°.

Alternate locations page 48

Reference	Ø D	L1			L2	P_-PSNS	Others shapes	
		71	80	100		ØP	W (min)	P / G (max)
<p>Shapes</p> <p>Material</p> <p>PB - PSNR</p> <p>(TMY) = E</p> <p>(TMX) = T</p> <p>(SPECIALS) = X</p>	2	A+B	A+B	A+B	10	0,7 - 1,95	0,7	1,95
	3	A+B	A+B	A+B	13	1,6 - 2,95	0,7	2,95
	4	A+B	A+B	A+B	16	2 - 3,95	1	3,95
	5	A+B	A+B	A+B	20	2 - 4,95	1	4,95
	6	A+B	A+B	A+B	20	3 - 5,95	1,5	5,95
	ØD and length "L1" : Others dimensions on request					Length L2 applied by default, others dimensions on request.		

Material	Body	Head
A = (X155CrVMo.12.1)	58 - 62	40 - 50 HRc
B = (Z90 WDCV 06050402)	60 - 64	47 - 57 HRc

+ Other materials on request.
Other cutting shapes (E ; T ; X) : page 46
Available coatings : page 55
Technical options : page 48

To order :

Punch HSS Micro Solid Blank D.body L1 L2

PB - PSNB - 6 - 71

Punch HSS Micro Solid Rectangle D.body L1 L2 Shape dimensions Flat Position

PB - PSNR - 6 - 71 - 20 - P5.2 - W3.2 - R2 - T90

Straight pilots

Reference	∅ D	L1	L2
Material PB - PPNP	8	25	14
8	30	19	
10	25	14	
10	30	19	
12	25	14	
12	30	19	

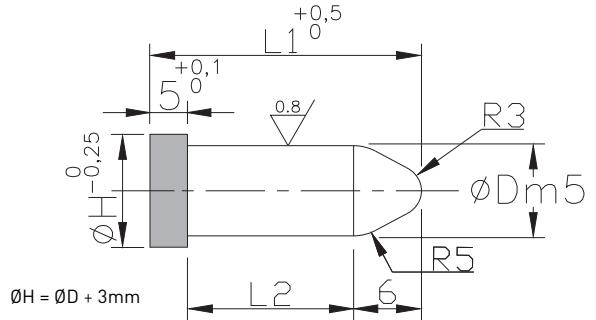

To order :

Punch HSS Heated Solid Pilot D.body L1
PB - PPNP - 12 - 30

Standard pilots

⚠ $LV = L1 + 6,5$

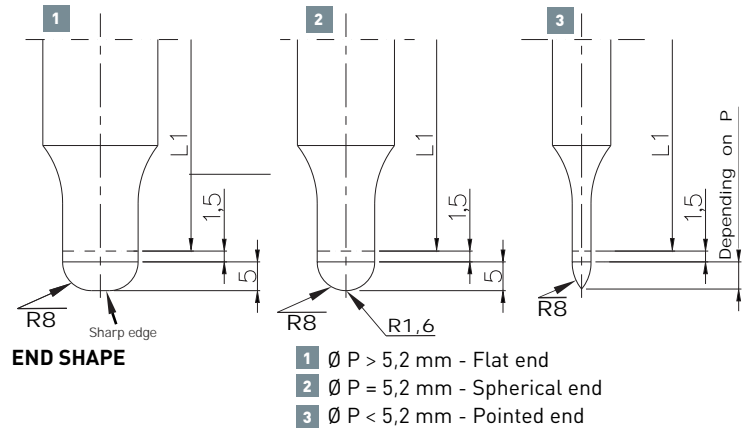
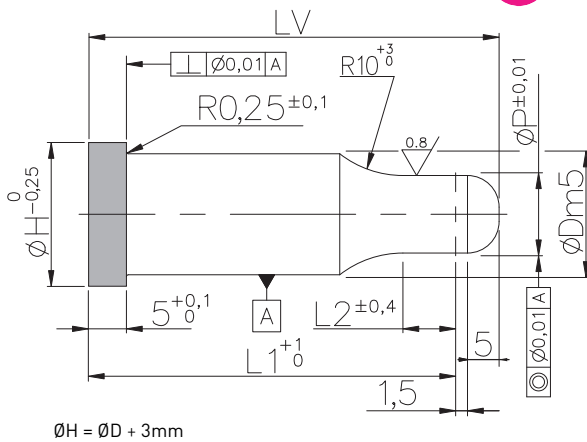

END SHAPE

- 1 ∅ P > 5,2 mm - Flat end
- 2 ∅ P = 5,2 mm - Spherical end
- 3 ∅ P < 5,2 mm - Pointed end

Reference	∅ D	L1				L2	∅ P
		71	80	90	110		
Material PB - PPNZ A	5	B	B	B	B	13	0,8 - 4,9
6	B	B	B	B	B	13	1,5 - 5,9
8	B	B	B	B	B	16	2,5 - 7,9
10	A+B	A+B	A+B	A+B	B	16	4,5 - 9,9
13	A+B	A+B	A+B	A+B	B	16	6,5 - 12,9
16	A+B	A+B	A+B	A+B	B	20	9,5 - 15,9
20	A+B	A+B	A+B	A+B	B	20	12,5 - 19,9
25	A+B	A+B	A+B	A+B	B	20	16,5 - 24,9

∅D and length "L1" : Others dimensions on request. Length L2 applied by default, others dimensions on request.

Material	Body	Head
A = (X155CrVMo.12.1)	58 - 62	40 - 50 HRc
B = (Z90 WDCV 06050402)	60 - 64	47 - 57 HRc

To order :

Punch HSS Heated Solid Pilot D.body L1 L2 Dimensions
PB - PPNZ - 16 - 71 - 20 - P12.5

➕ Other materials on request.

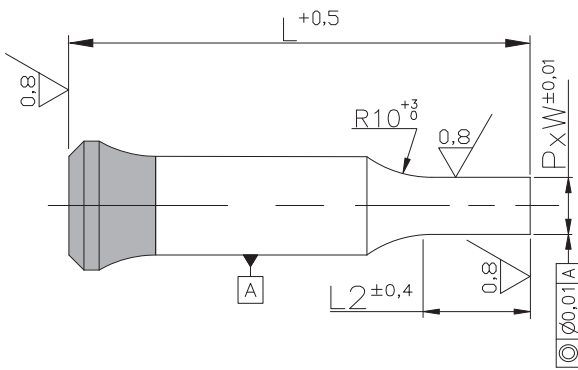
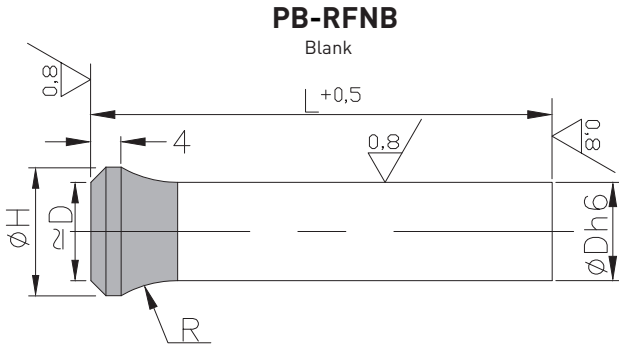

! $G = \sqrt{P^2 + W^2}$. $G \leq \text{ØD} - 0,1$

PB-RFNS
Round

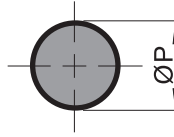

PB-RFNF
Rounded rectangle

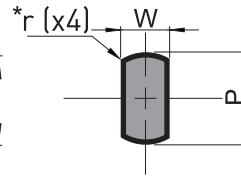

PB-RFNV
Square

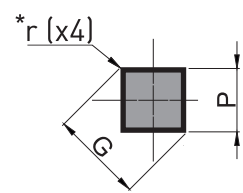

PB-RFNL
Oblong

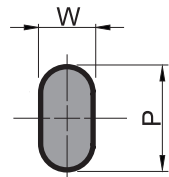

PB-RFNR
Rectangle

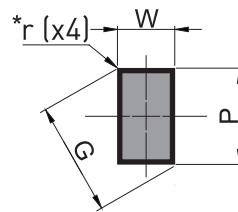

PB-RFNH
Hexagon

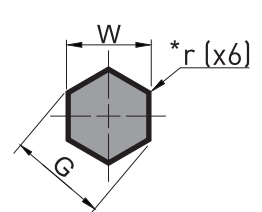

*Angle radius is r=0 by default
(If you want a radius of 1.5mm please specify r1.5)

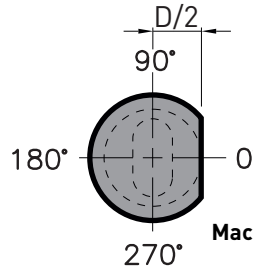

+ Flat location on demand
Example : R2T0 Flat tangent to the body at 0°.

Alternate locations page 48

Machining tool and seat for tapered head page 31

Reference	Ø D	L1				L2	PB-RFNS			Others shapes		Ø H	R
		71	80	100	120		ØP	W (min)	P / G (max)				
	5	B	B	B	B	10	1,0 - 4,9	1,5	4,9	7	10		
	5,5	B	B	B	B	10	1,2 - 5,4	1,5	5,4	8	10		
	6	B	B	B	B	10	1,5 - 5,9	1,5	5,9	9	10		
	6,5	B	B	B	B	10	1,7 - 6,4	1,6	6,4	9,5	12		
	7	B	B	B	B	10	2,0 - 6,9	1,7	6,9	10	12		
	7,5	B	B	B	B	13	2,1 - 7,4	1,9	7,4	11	12		
	8	B	B	B	B	13	2,5 - 7,9	2	7,9	11	12		
	8,5	B	B	B	B	13	3,0 - 8,4	2,4	8,4	13	15		
	9	B	B	B	B	13	3,5 - 8,9	2,7	8,9	13	15		
	9,5	B	B	B	B	13	4,0 - 9,4	3,1	9,4	14	15		
	10	B	B	B	B	13	4,5 - 9,9	3,5	9,9	14	15		
	10,5	B	B	B	B	13	4,9 - 10,4	3,7	10,4	15	15		
	11	B	B	B	B	13	5,1 - 10,9	3,8	10,9	15	15		
	11,5	B	B	B	B	16	5,7 - 11,4	4	11,4	16	15		
	12	B	B	B	B	16	5,8 - 11,9	4,2	11,9	16	15		
	13	B	B	B	B	16	6,5 - 12,9	4,5	12,9	17	15		
	14	B	B	B	B	16	7,5 - 13,9	5,1	13,9	18	15		
	15	B	B	B	B	20	8,5 - 14,9	5,7	14,9	19	15		
	16	B	B	B	B	20	9,5 - 15,9	6	15,9	20	15		
	17	B	B	B	B	20	9,5 - 16,9	6,5	16,9	21	15		
	18	B	B	B	B	20	10,5 - 17,9	7	17,9	22	15		
	19	B	B	B	B	20	10,5 - 18,9	7,5	18,9	23	15		
	20	B	B	B	B	20	12,5 - 19,9	8	19,9	25	15		
	25	B	B	B	B	20	16,5 - 24,9	10	24,9	30	15		

ØD and length "L1" : Others dimensions on request.

Length L2 applied by default, others dimensions on request.

Material	Body	Head
B = (Z90 WDCV 06050402)	60 - 64	47 - 57 HRc

To order :

Punch HSS Tapered Solid Blank D.body L1 L2

PB - RFNB - 16 - 71

Punch HSS Tapered Solid Rectangle D.body L1 L2 Shape dimensions Flat Position

PB - RFNR - 16 - 71 - 20 - P10.2 - W7.2 - R2 - T90

+ Other materials on request.
Other cutting shapes (E ; T ; X) : page 46
Available coatings : page 55
Technical options : page 48

NEW

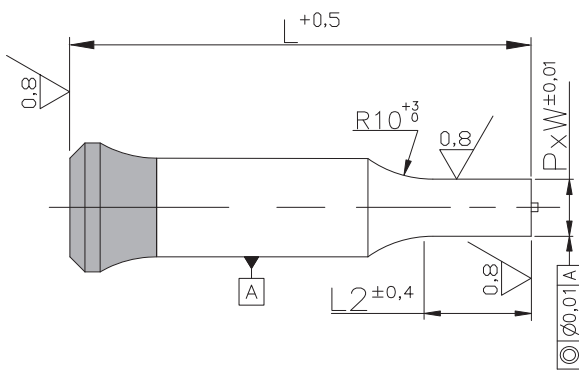
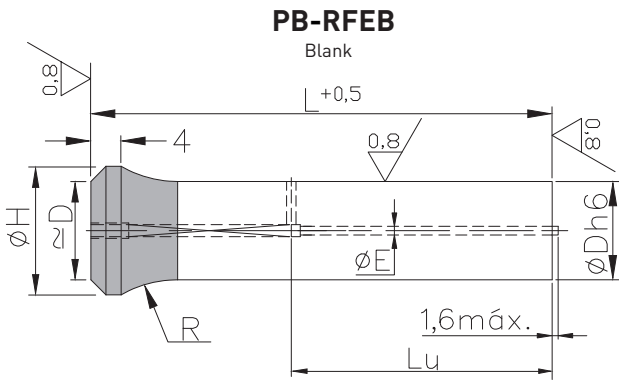

! $G = \sqrt{P^2 + W^2}$. $G \leq \text{ØD} - 0,1$

PB-RFES
Round

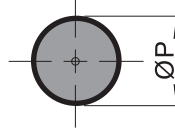

PB-RFEF
Rounded rectangle

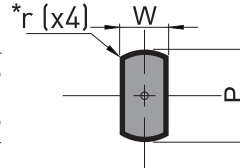

PB-RFEV
Square

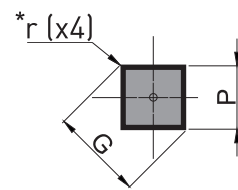

PB-RFEL
Oblong

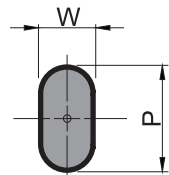

PB-RFER
Rectangle

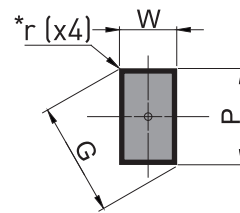

PB-RFEH
Hexagon

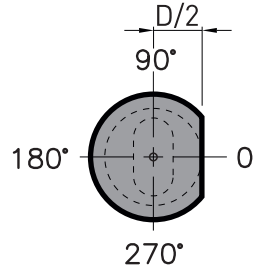
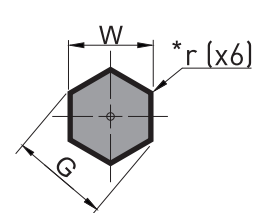

*Angle radius is r=0 by default
(If you want a radius of 1.5mm please specify r1.5)



Flat location on demand
Example : R2T0 Flat tangent to the body at 0°.

Alternate locations page 48
Machining tool and seat for tapered head page 31

Reference	Ø D	L1			L2	ØE	PB-RFES	Others shapes		Ø H	R
		71	80	100			ØP	W (min)	P / G (max)		
PB - RFER Shapes: S, L, F, V, H Material: (TMY) = E, (TMX) = T, (SPECIALS) = X	8	B	B	B	13	1,1	2,5 - 7,9	3	7,9	11	12
	10	B	B	B	13	1,3	4,5 - 9,9	4,5	9,9	14	15
	13	B	B	B	16	2,2	6,5 - 12,9	6	12,9	17	15
	16	B	B	B	20	2,2	9,5 - 15,9	7	15,9	20	15
	20	B	B	B	20	2,2	12,5 - 19,9	8	19,9	25	15
	25	B	B	B	20	2,2	16,5 - 24,9	10	24,9	30	15
ØD and length "L1" : Others dimensions on request.		LU			Length L2 applied by default, others dimensions on request.						
		39	48	68							

Material	Body	Head
B = (Z90 WDCV 06050402)	60 - 64	47 - 57 HRc

+ Other materials on request.
Other cutting shapes (E ; T ; X) : page 46
Available coatings : page 55
Technical options : page 48

To order :									
Punch H2S	Tapered	Solid	Blank	D.body	L1	L2	Shape dimensions	Flat	Shaped Position
PB - RFEB - 16 - 71									
Punch H2S	Tapered	Solid	Oblong	D.body	L1	L2	Shape dimensions	Flat	Shaped Position
PB - RFEL - 16 - 71 - 20 - P10.2 - W7.2 - R2 - T0									

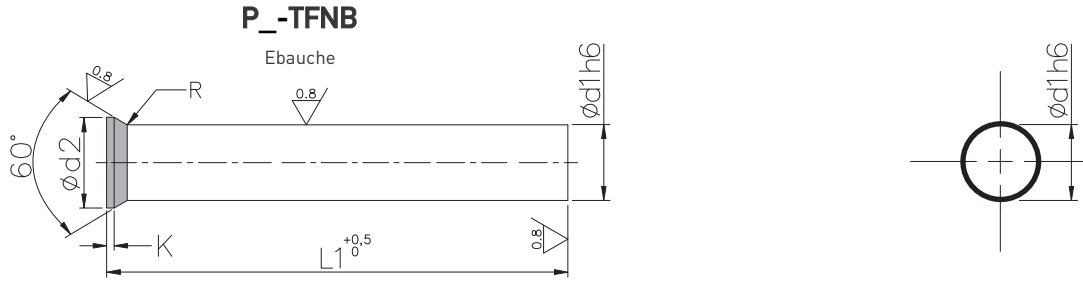

Reference	Ø d1	Ø d2	K	L1		Ø d1	Ø d2	K	L1		Ø d1	Ø d2	K	L1	
				71	100				71	100				71	100
Material PB - TFNB - Ød1 - L1 A	0,5	0,9	0,2	A+B	A	5,8	7	0,5	A+B	A+B	11,1	13	1	A	A
	0,6	1,1		A+B	A	5,9	8		A+B	A+B	11,2			A	A
	0,7	1,3		A+B	A	6			A+B	A+B	11,3			A	A
	0,8	1,4	A+B	A	6,1	9		A+B	A+B	11,4	A	A			
	0,9	1,6	A+B	A	6,2		A+B	A+B	11,5	A+B	A+B				
	1	1,8	A+B	A+B	6,3		A+B	A+B	11,6	A	A				
	1,1	2	0,4	A+B	A+B	6,4	10	A+B	A+B	11,7	A	A			
	1,2			A+B	A+B	6,5		A+B	A+B	11,8	A	A			
	1,3			A+B	A+B	6,6		A+B	A+B	11,9	A	A			
	1,4	2,2	0,5	A+B	A+B	6,7	11	A+B	A+B	12	A+B	A+B			
	1,5	A+B		A+B	6,8	A+B		A+B	12,1	A	A				
	1,6	2,5		A+B	A+B	6,9		A+B	A+B	12,2	A	A			
	1,7	2,8	0,4	A+B	A+B	7	12	A+B	A+B	12,3	A	A			
	1,8			A+B	A+B	7,1		A+B	A+B	12,4	A	A			
	1,9			A+B	A+B	7,2		A+B	A+B	12,5	A+B	A+B			
	2	3	A+B	A+B	7,3	13	A+B	A+B	12,6	A	A				
	2,1	3,2	0,5	A+B	A+B		7,4	A+B	A+B	12,7	A	A			
	2,2			A+B	A+B		7,5	A+B	A+B	12,8	A	A			
	2,3			A+B	A+B	7,6	A+B	A+B	12,9	A	A				
	2,4	3,5	0,5	A+B	A+B	7,7	14	A+B	A+B	13	A+B	A+B			
	2,5	A+B		A+B	7,8	A+B		A+B	13,1	A	A				
	2,6	A+B		A+B	7,9	A+B		A+B	13,2	A	A				
	2,7	4	0,5	A+B	A+B	8	15	A+B	A+B	13,3	A	A			
	2,8			A+B	A+B	8,1		A+B	A+B	13,4	A	A			
	2,9			A+B	A+B	8,2		A+B	A+B	13,5	A+B	A+B			
	3	4,5	0,5	A+B	A+B	8,3	16	A+B	A+B	13,6	A	A			
	3,1			A+B	A+B	8,4		A+B	A+B	13,7	A	A			
	3,2			A+B	A+B	8,5		A+B	A+B	13,8	A	A			
	3,3	5	0,5	A+B	A+B	8,6	17	A+B	A+B	13,9	A	A			
	3,4			A+B	A+B	8,7		A+B	A+B	14	A+B	A+B			
	3,5			A+B	A+B	8,8		A+B	A+B	14,1	A	A			
	3,6	5,5	0,5	A+B	A+B	8,9	18	A+B	A+B	14,2	A	A			
	3,7			A+B	A+B	9		A+B	A+B	14,3	A	A			
	3,8			A+B	A+B	9,1		A+B	A+B	14,4	A	A			
	3,9	6	1,5	A+B	A+B	9,2	19	A+B	A+B	14,5	A+B	A+B			
	4			A+B	A+B	9,3		A+B	A+B	14,6	A	A			
	4,1			A+B	A+B	9,4		A+B	A+B	14,7	A	A			
	4,2	6,5	1,5	A+B	A+B	9,5	20	A+B	A+B	14,8	A	A			
	4,3			A+B	A+B	9,6		A+B	A+B	14,9	A	A			
	4,4			A+B	A+B	9,7		A+B	A+B	15	A+B	A+B			
	4,5	7	1,5	A+B	A+B	9,8	21	A+B	A+B	15,1	A	A			
	4,6			A+B	A+B	9,9		A+B	A+B	15,2	A	A			
	4,7			A+B	A+B	10		A+B	A+B	15,3	A	A			
	4,8	7,5	1,5	A+B	A+B	10,1	22	A	A	15,4	A	A			
	4,9			A+B	A+B	10,2		A	A	15,5	A+B	A+B			
	5			A+B	A+B	10,3		A	A	15,6	A	A			
	5,1	8	1,5	A+B	A+B	10,4	23	A	A	15,7	A	A			
	5,2			A+B	A+B	10,5		A+B	A+B	15,8	A	A			
	5,3			A+B	A+B	10,6		A	A	15,9	A	A			
	5,4	8,5	1,5	A+B	A+B	10,7	24	A	A	16	A+B	A+B			
5,5	A+B			A+B	10,8	A		A							
5,6	A+B			A+B	10,9	A		A							
5,7	9		A+B	A+B	11										

ØD and length "L1" : Others dimensions on request.

Material	Body	Head
A = (X155CrVMo.12.1)	58 - 62	40 - 50 HRc
B = (Z90 WDCV 06050402)	60 - 64	47 - 57 HRc

To order :

Punch HSS
Conical head 60°
Solid
Blank
D.body
L1
PB - TFNB - 3.4 - 100

Blank

Other materials on request

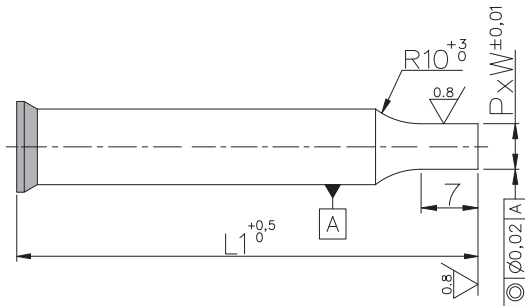

P_-TFNS
Round

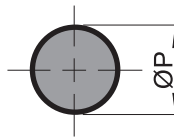

P_-TFNF
Rounded rectangle

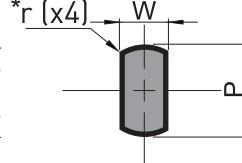

P_-TFNV
Square

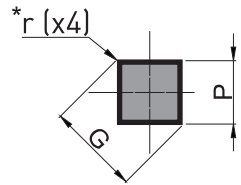

P_-TFNL
Oblong

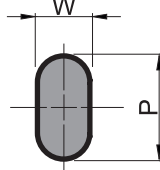

P_-TFNR
Rectangle

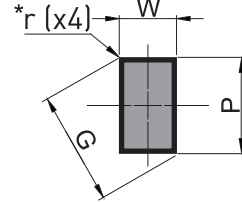

P_-TFNH
Hexagon

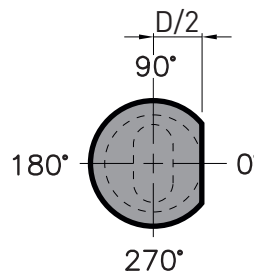
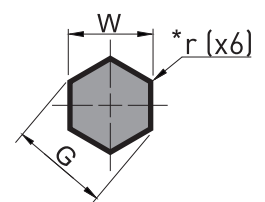

*Angle radius is r=0 by default
(If you want a radius of 1.5mm please specify r1.5)



Flat location on demand
Example : R2T0 Flat tangent to the body at 0°.

Alternate locations page 48

! $G = \sqrt{P^2 + W^2}$. $G \leq \text{ØD} - 0,1$

Reference	Ø d1	L1		P_-TFNS	Others shapes		Ø d2	K
		71	80	ØP	W (min)	P / G (max)		
	2	A+B	A+B	0,7 - 1,9	0,7	1,9	3	0,5
	3	A+B	A+B	1,0 - 2,9	1	2,9	4,5	0,5
	4	A+B	A+B	1,0 - 3,9	1,5	3,9	5,5	0,5
	5	A+B	A+B	1,0 - 4,9	1,5	4,9	6,5	0,5
	6	A+B	A+B	1,5 - 5,9	1,5	5,9	8	0,5
	7	A+B	A+B	2,0 - 6,9	1,7	6,9	9	1
	8	A+B	A+B	2,5 - 7,9	2	7,9	10	1
	9	A+B	A+B	3,5 - 8,9	2,7	8,9	11	1
	10	A+B	A+B	4,5 - 9,9	3,5	9,9	12	1
	11	A+B	A+B	5,1 - 10,9	3,8	10,9	13	1
	12	A+B	A+B	5,8 - 11,9	4,2	11,9	14	1
	13	A+B	A+B	6,5 - 12,9	4,5	12,9	15	1
	14	A+B	A+B	7,5 - 13,9	5,1	13,9	16	1,5
	15	A+B	A+B	8,5 - 14,9	5,7	14,9	17	1,5
	16	A+B	A+B	9,5 - 15,9	6	15,9	18	1,5

ØD and length "L1" : Others dimensions on request. Length L2 applied by default is 7mm, others dimensions on request.

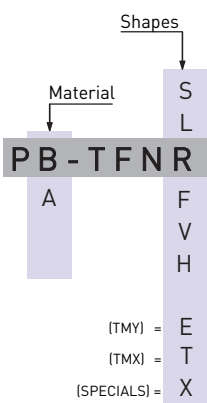

Material	Body	Head
A = (X155CrVMo.12.1)	58 - 62	40 - 50 HRc
B = (Z90 WDCV 06050402)	60 - 64	47 - 57 HRc

To order :

Punch	HSS	Conical head tip	Solid	Oblong	D body	L1	L2	Shape dimensions	Flat	Position	Shaped	
P	B	T	F	N	L	- 10	- 71	- 7	- P9	- W5	- R2	- T0

+ Other materials on request.
Other cutting shapes (E ; T ; X) : page 46
Available coatings : page 55
Technical options : page 48

NEW

PB-TFEB

Blank

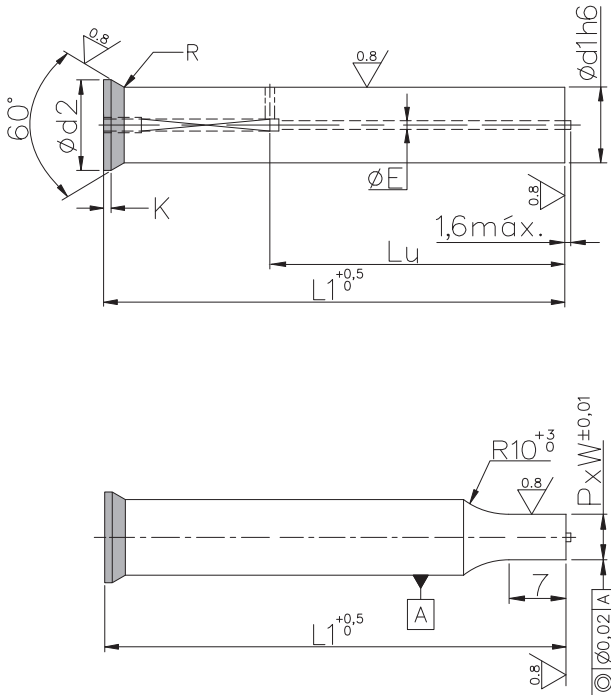

! $G = \sqrt{P^2 + W^2} \cdot G \leq \text{ØD} - 0,1$

PB-TFES

Round

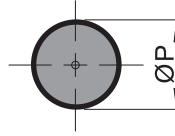

PB-TFEF

Rounded rectangle

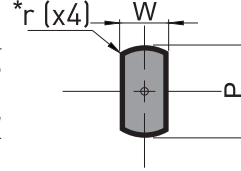

PB-TFEV

Square

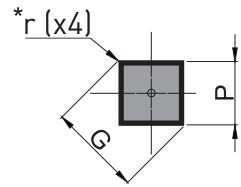

PB-TFEL

Oblong

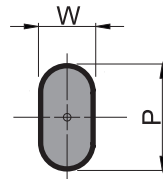

PB-TFER

Rectangle

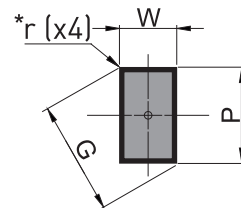

PB-TFEH

Hexagon

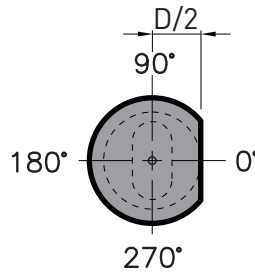
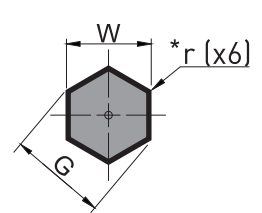

*Angle radius is r=0 by default
(If you want a radius of 1.5mm please specify r1.5)



Flat location on demand
Example : R2T0 Flat tangent to the body at 0°.

Alternate locations page 48

Reference	Ø D	L1		P_TFES	Others shapes		ØE	Ød2	K
		71	100	ØP	W (min)	P / G (max)			
Shapes S L PB-TFER F V H (TMY) = E (TMX) = T (SPECIALS) = X	8	B	B	3 - 7,9	3	7,9	1,1	10	1
	10	B	B	4,5 - 9,9	4,5	9,9	1,3	12	1
	12	B	B	5,8 - 11,9	5,8	11,9	1,3	14	1
	14	B	B	7,5 - 13,9	6	13,9	1,3	16	1,5
	16	B	B	9,5 - 15,9	7	15,9	2,2	18	1,5
ØD and length "L1" : Others dimensions on request.		LU		Length L2 applied by default is 7mm, others dimensions on request.					
		39	68						

Material	Body	Head
B = (Z90 WDCV 06050402)	60 - 64	47 - 57 HRc

+ Other materials on request.
Other cutting shapes (E ; T ; X) : page 46
Available coatings : page 55
Technical options : page 48

To order :									
Punch HSS	Conical head 60°	Ejector	Blank	D.body	L1	Blank			
PB-TFEB-10-71									
Punch HSS	Conical head 60°	Ejector	Oblong	D.body	L1	L2	Shape dimensions	Flat	Position
PB-TFEL-10-71-7-P7-W5-R2-T0									

NEW

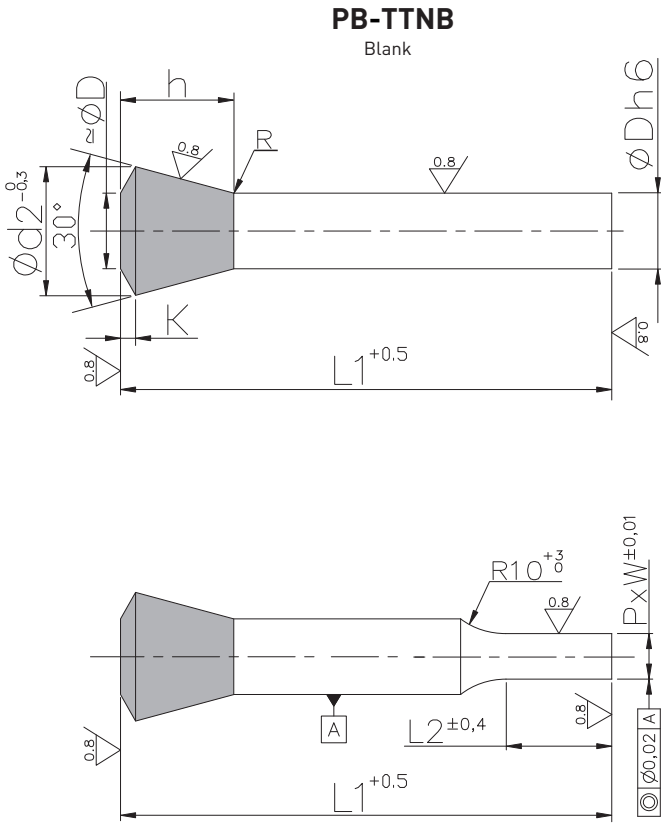

PB-TTNS
Round

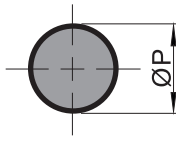

PB-TTNF
Rounded rectangle

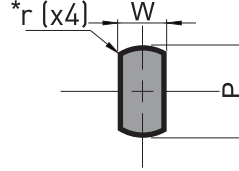

PB-TTNV
Square

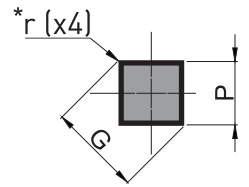

PB-TTNL
Oblong

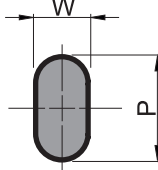

PB-TTNR
Rectangle

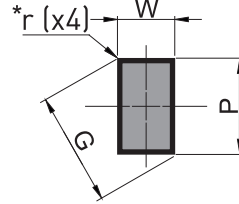

PB-TTNH
Hexagon

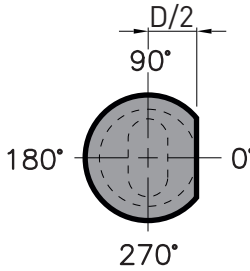
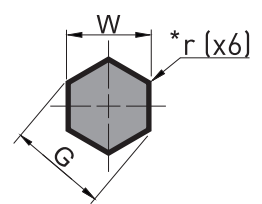

*Angle radius is r=0 by default
(If you want a radius of 1.5mm please specify r1.5)

Flat location on demand
Example : R2T0 Flat tangent to the body at 0°.



Alternate locations page 48



$$G = \sqrt{P^2 + W^2} \cdot G \leq \text{ØD} - 0,1$$

Reference	Ø D	L1		L2	PB-TTNS	Others shapes		Ød2	K	h
		100	120		ØP	W (min)	P / G (max)			
Shapes S L PB-TTNR F V H (TMY) = E (TMX) = T (SPECIALS) = X	6	B	B	13	1,5 - 5,9	1,5	5,9	10	1	8
	8	B	B	13	2,5 - 7,9	2	7,9	13	1	10
	9	B	B	20	3,5 - 8,9	2,7	8,9	14,5	1	11
	10	B	B	20	4,5 - 9,9	3,5	9,9	16	1	12
	12		B	20	5,8 - 11,9	4,2	11,9	19	1,5	14
	14		B	20	7,5 - 13,9	5,1	13,9	22	1,5	16
	16		B	20	9,5 - 15,9	6	15,9	24,7	1,5	18
ØD and length "L1" : Others dimensions on request					Length L2 applied by default, others dimensions on request.					

Material	Body	Head
B = (Z90 WDCV 06050402)	60 - 64	47 - 57 HRc



Other materials on request.
Other cutting shapes (E ; T ; X) : page 46

Available coatings : page 55
Technical options : page 48

To order :

Blank

Punch HSS Conical head 30° Solid Blank D.body L1
PB-TTNB-10-100

Shaped

Punch HSS Conical head 30° Solid Rectangle D.body L1 L2 Shape dimensions Flat Position
PB-TTNR-10-100-20-P5.5-W4.1-R2-T90

NEW

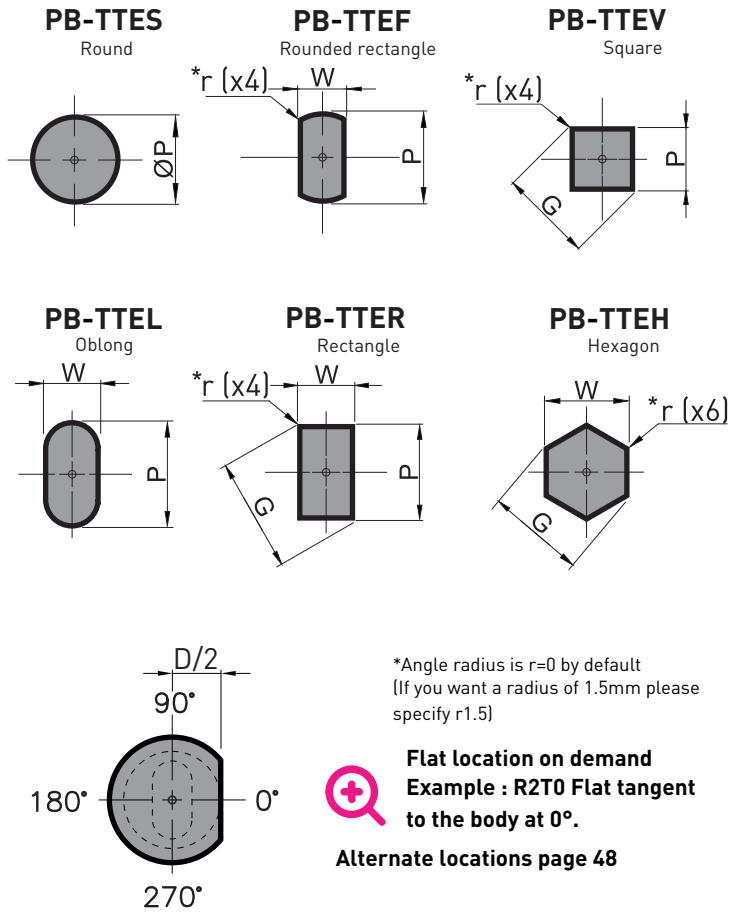
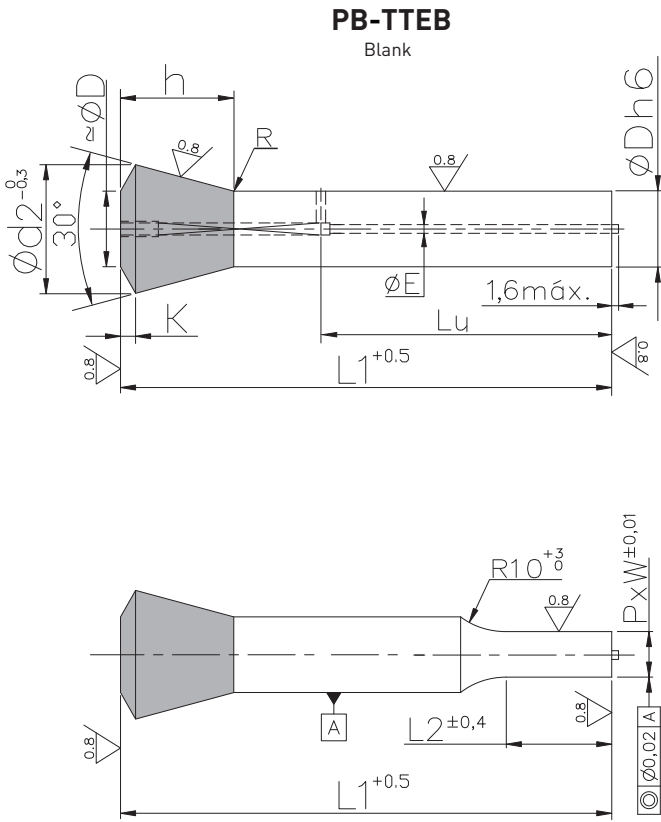

*Angle radius is r=0 by default
(If you want a radius of 1.5mm please specify r1.5)

Flat location on demand
Example : R2T0 Flat tangent to the body at 0°.



Alternate locations page 48

! $G = \sqrt{P^2 + W^2} \cdot G \leq \text{ØD} - 0,1$

Reference	Ø D	L1		L2	PB-TTES ØP	Others shapes		Ød2	K	h	ØE
		100	120			W (min)	P / G (max)				
Shapes Material PB-TTER S L F V H (TMY) = E (TMX) = T (SPECIALS) = X	6	B		13	2,5 - 5,9	2,5	5,9	10	1	8	1,1
	8	B	B	16	3 - 7,9	3	7,9	13	1	10	1,1
	10	B	B	20	4,5 - 9,9	4,5	9,9	16	1	12	1,3
	12	B	B	20	5,8 - 11,9	5,8	11,9	19	1,5	14	1,3
	14	B	B	20	7,5 - 13,9	6	13,9	22	1,5	16	2,2
	16	B	B	20	9,5 - 15,9	7	15,9	24,7	2	18	2,2
ØD and length "L1" : Others dimensions on request.		LU		Length L2 applied by default , others dimensions on request.							
		68	68								

Matière:	Corps	Tête
B = [Z90 WDCV 06050402]	60 - 64	47 - 57 HRc

+ Other materials on request.
Other cutting shapes (E ; T ; X) : page 46
Available coatings : page 55
Technical options : page 48

To order :									
Punch HSS	Conical head 30°	Solid	Blank	D.body	L1	Blank			
PB-TTEB - 10 - 100									
Punch HSS	Conical head 30°	Solid	Rectangle	D.body	L1	L2	Shape dimensions	Flat	Position
PB-TTER - 10 - 100 - 20 - P6.5 - W5.1 - R2 - T90									

P_-BLNB / P_-BHNБ

Blank
Light duty / Heavy duty

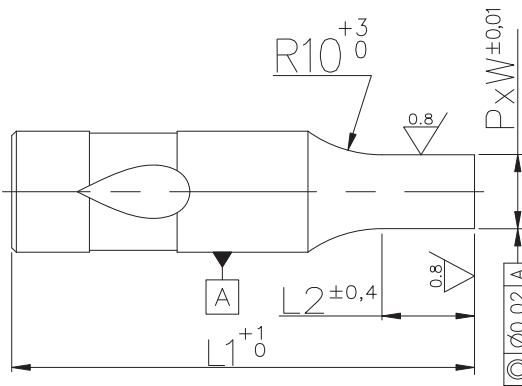
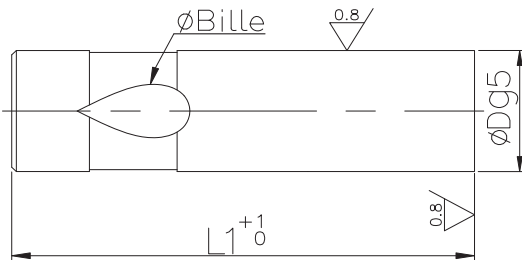

! $G = \sqrt{P^2 + W^2}$. $G \leq \text{ØD} - 0,1$

P_-BLNS / P_-BHNS P_-BLNF / P_-BHNF P_-BLNV / P_-BHNV

Round Rounded rectangle Square

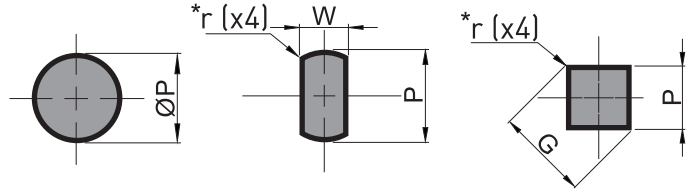

P_-BLNL / P_-BHNL P_-BLNR / P_-BHNR P_-BLNH / P_-BHNH

Oblong Rectangle Hexagon

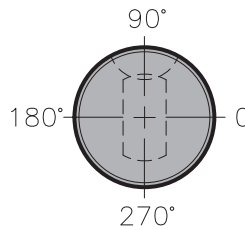
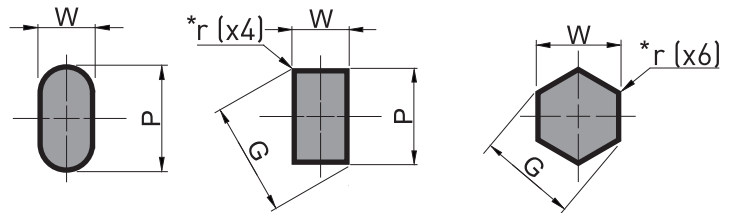

*Angle radius is r=0 by default
(If you want a radius of 1.5mm please specify r1.5)

! Shape made by default at T=90°
from the ball seat as shown in
the drawings following drawing
opposite

Reference	Ø D	L1				L2	P_-B_NS		Others shapes		Ø Ball
		71	80	100	125		ØP	W (min)	P / G (max)		
LIGHT DUTY											
Material PA - BLNR Shapes	10	A+B	A+B	B	B	13	4,5 - 9,9	3,5	9,9	8	
	13	A+B	A+B	B	B	16	6,5 - 12,9	4,5	12,9	8	
	16	A+B	A+B	B	B	20	9,5 - 15,9	6	15,9	8	
	20	A+B	A+B	B	B	20	12,5 - 19,9	8	19,9	8	
	25	A+B	A+B	B	B	20	16,5 - 24,9	10	24,9	8	
HEAVY DUTY											
Material PB - BHNВ Shapes	10	B	B	B	B	13	4,5 - 9,9	4,5	9,9	10	
	13	B	B	B	B	16	6,5 - 12,9	6	12,9	12	
	16	B	B	B	B	20	9,5 - 15,9	6	15,9	12	
	20	B	B	B	B	20	12,5 - 19,9	8	19,9	12	
	25	B	B	B	B	20	18 - 24,9	10	24,9	12	
	40	B	B	B	B	20	30,5 - 39,9	14	39,9	12	

ØD and length "L1" : Others dimensions on request. Length L2 applied by default, others dimensions on request.

Material	Body	Head
A = (X155CrVMo.12.1)	58 - 62	40 - 50 HRc
B = (Z90 WDCV 06050402)	60 - 64	47 - 57 HRc

To order :

Punch HSS Heavy duty Solid Blank D.body L1 L2 Shaped

PB - BHNБ - 16 - 71

Punch HSS Heavy duty Solid Square D.body L1 L2 Shape dimensions Position

PB - BHNВ - 16 - 71 - 20 - P10.2 - r1.5 - T90

+ Other materials on request.
Other cutting shapes (E ; T ; X) : page 46
Available coatings : page 55
Technical options : page 48

P_-BLEB / P_-BHEB

Blank
Light duty / Heavy duty

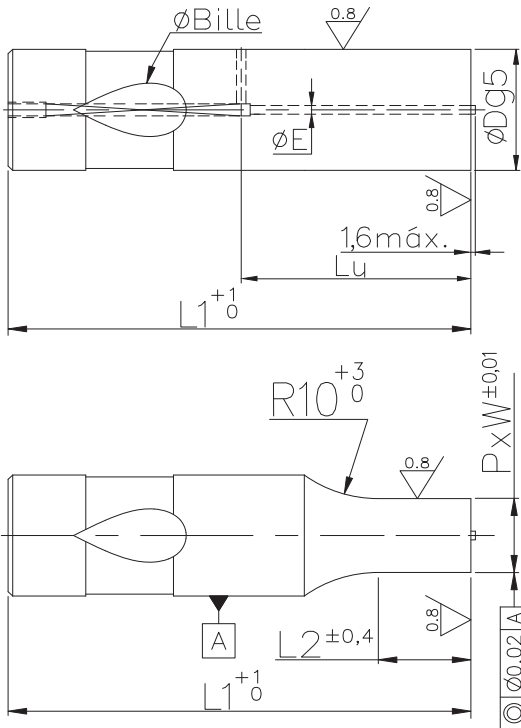

! $G = \sqrt{P^2 + W^2}$. $G \leq \text{ØD} - 0,1$

P_-BLES / P_-BHES

Round

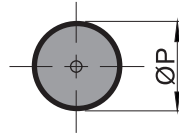

P_-BLEF / P_-BHEF

Rounded rectangle

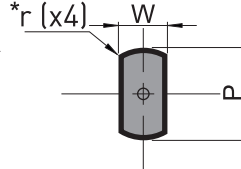

P_-BLEV / P_-BHEV

Square

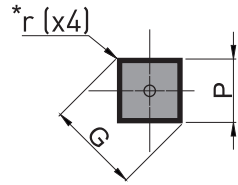

P_-BLEL / P_-BHEL

Oblong

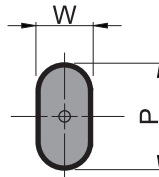

P_-BLER / P_-BHER

Rectangle

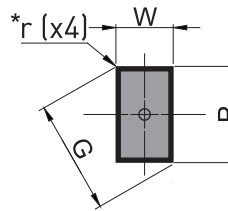

P_-BLEH / P_-BHEH

Hexagon

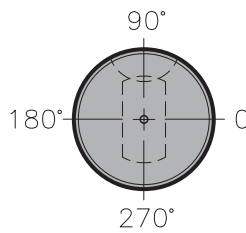
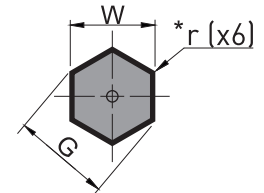

*Angle radius is r=0 by default
(If you want a radius of 1.5mm please specify r1.5)

! Shape made by default at T=90° from the ball seat as shown in the drawings following drawing opposite

Reference	Ø D	L1				L2	P_-B_ES		Others shapes		Ø E	Ø Ball
		71	80	100	125		ØP	W (min)	P / G (max)			
LIGHT DUTY												
PB-BLER	10	B	B	B		13	4,5 - 9,9	4,5	9,9	1,3	8	
	13	B	B	B		16	6,5 - 12,9	6	12,9	1,3	8	
	16	B	B	B		20	9,5 - 15,9	7	15,9	2,2	8	
	20	B	B	B		20	12,5 - 19,9	8	19,9	2,2	8	
	25	B	B	B		20	16,5 - 24,9	10	24,9	2,2	8	
HEAVY DUTY												
PB-BHEV	10	B	B	B		13	5,5 - 9,9	5,5	9,9	1,3	10	
	13	B	B	B	B	16	8 - 12,9	8	12,9	1,3	12	
	16	B	B	B	B	20	9,5 - 15,9	9,5	15,9	2,2	12	
	20	B	B	B	B	20	12,5 - 19,9	12,5	19,9	2,2	12	
	25	B	B	B	B	20	18 - 24,9	18	24,9	2,2	12	
	32	B	B	B	B	20	24 - 31,9	18	31,9	2,2	12	
40	B	B	B	B	20	30,5 - 39,9	18	39,9	2,2	12		
ØD and length "L1" : Others dimensions on request.		LU				Length L2 applied by default, others dimensions on request.						
		39	48	68	68							

Matière:	Corps	Tête
B = [Z90 WDCV 06050402]	60 - 64	47 - 57 HRC

+ Other materials on request.
Other cutting shapes (E ; T ; X) : page 46
Available coatings : page 55
Technical options : page 48

To order :

Punch HSS Light duty Ejector Blank D.body L1
PB-BLEB-16-71 Blank

Punch HSS Light duty Ejector Oblong D.body L1 L2 Shape dimensions Position
PB-BLEL-16-71-20-P15.2-W8.2-T0 Shaped

P_-BJNB / P_-BKNB

Blank
Light duty / Heavy duty

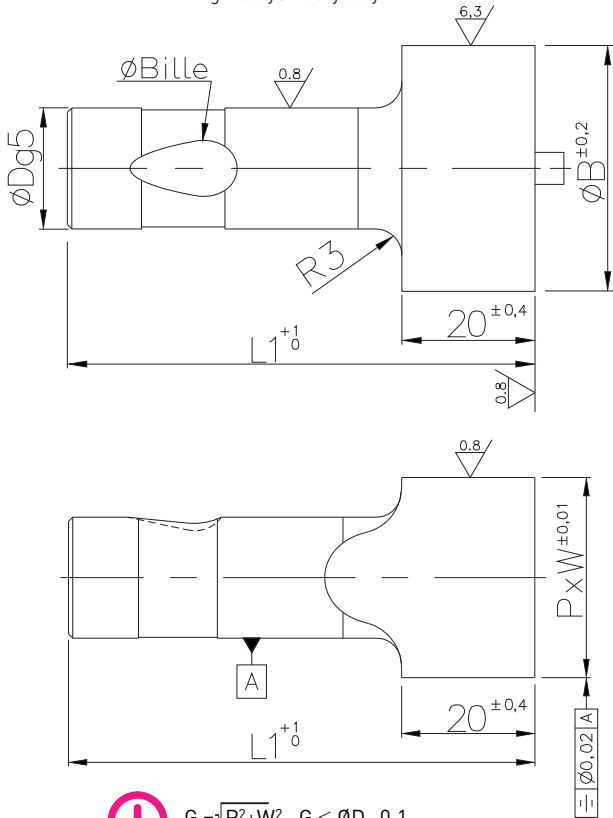

! $G = \sqrt{P^2 + W^2} \cdot G \leq \varnothing D - 0,1$

P_-BJNS / P_-BKNS

Round

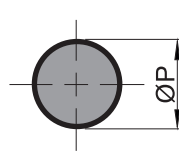

P_-BJNF / P_-BKNF

Rounded rectangle

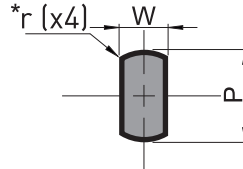

P_-BJNV / P_-BKNV

Square

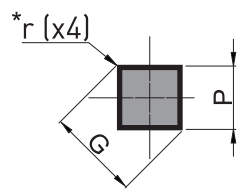

P_-BJNL / P_-BKNL

Oblong

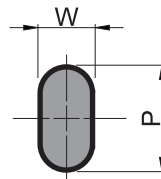

P_-BJNR / P_-BKNR

Rectangle

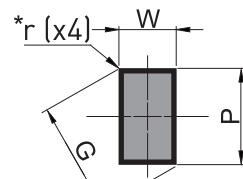

P_-BJNH / P_-BKNH

Hexagon

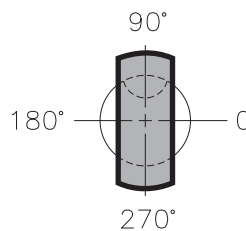
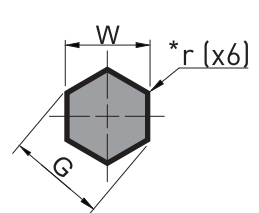

*Angle radius is $r=0$ by default
(If you want a radius of 1.5mm please specify $r1.5$)

! Shape made by default at $T=90^\circ$ from the ball seat as shown in the drawings following drawing opposite

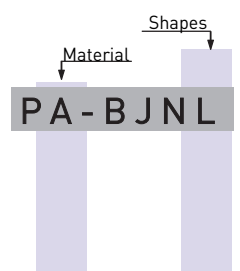
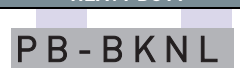
Reference	$\varnothing D$	L1		P_-B_NS	Others shapes	$\varnothing B$	\varnothing Ball
		71	80	$\varnothing P$	G (max)		
LIGHT DUTY							
 <p>PA - BJNL</p>	10	B	A+B	12 - 20	20	20,5	8
	13	B	A+B	15 - 29,5	29,5	30	8
	16	B	A+B	18 - 32	32	32,5	8
	20	B	A+B	22 - 38	38	38,5	8
	25	B	A+B	28 - 47,5	47,5	48	8
	32	B	A+B	35 - 49,5	49,5	50	8
	40	B	A+B	43 - 55,5	55,5	56	8
HEAVY DUTY							
 <p>PB - BKNL</p>	32	B	B	35 - 49,5	49,5	50	12
	40	B	B	43 - 55,5	55,5	56	12

Material	Body	Head
A = (X155CrVMo.12.1)	58 - 62	40 - 50 HRc
B = (Z90 WDCV 06050402)	60 - 64	47 - 57 HRc

To order :

Punch HSS Light duty Solid Blank D.body L1
PB - BJNB - 16 - 71 Blank

Punch HSS Light duty Solid Oblong D.body L1 Shape dimensions Position
PB - BJNL - 16 - 71 - P28.2 - W20.5 - T0 Shaped

+ Other materials on request.
 Other cutting shapes (E ; T ; X) : page 46
 Available coatings : page 55
 Technical options : page 48

DIE BUTTONS CODIFICATIONS

A = Material

X155CrVMo12.1/1.2379/HWS/D2	A
Z90/HSS/1.3343/M2/HS 6.5.2	B
Carbure	C
ASP23/1.3395/M32/HS 6.5.3	E
XII0CrMoV8-2	K
M4/1.3351/HS 6.5.4	S

C = Type of relief

WEDM Blank	W
Counterbore relief	C
Taper relief	D
Solid	N

Ø Body (mm)

Total length (mm)

H
Working Height

D = Metric die
(E = inches dimensions)

DA-HMCR-10-32-8-P6.3-W4.9

P - W
Shape dimensions

HM = Type

Headed, m5 Body (ISO8977)	HM
Headed, h5 Body (CNOMO)	HH
Straight, m5 Body (ISO8977)	SM
Straight, h5 Body (CNOMO)	SH
Straight, n5 Body/j6 (NAAMS)	SN
Straight, h5 Body, Screw Lock (CNOMO)	SC
Low profile straight reversible, h5 Body (CNOMO)	SR
Low Profile Straight Non-Reversible, h5 Body (CNOMO)	SS
Ball-lock	BL

R = Shapes

Blank	B
Blank with alteration	A
Round	S
Oblong	L
Square	V
Rectangle	R
Rounded rectangle	F
Hexagon	H
Classified Shapes - TMX	T
Classified Shapes - TMY	E
Special	X

HEADLESS DIE BUTTON TAPER RELIEF

ISO 8977 Standard - AFNOR NFE 63080

D_-SMWB
D_-SMD
D_-SHWB
D_-SHD

D_-SMWB ØDm5

D_-SHWB ØDh5

Blank

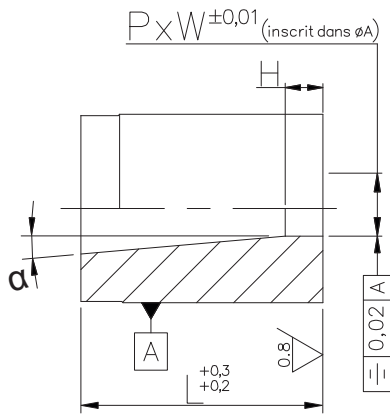
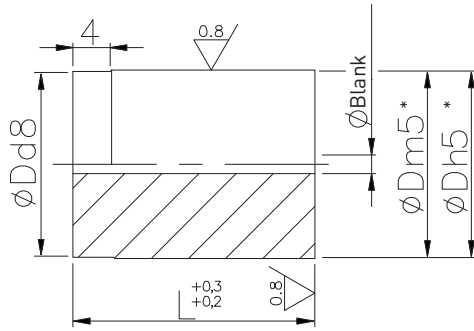

α = 1° by default
H = 5 by default

D_-SMDS ØDm5

D_-SHDS ØDh5

Round

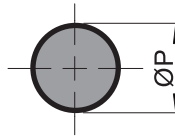

D_-SMDL ØDm5

D_-SHDL ØDh5

Oblong

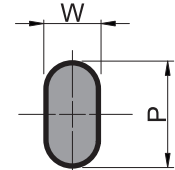

D_-SMDF ØDm5

D_-SHDF ØDh5

Rounded rectangle

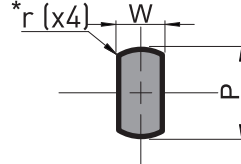

D_-SMDF ØDm5

D_-SHDF ØDh5

Rectangle

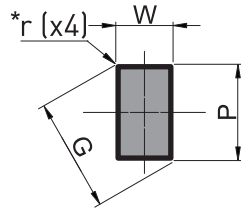

D_-SMDV ØDm5

D_-SHDV ØDh5

Square

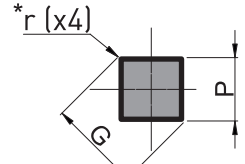

D_-SMDH ØDm5

D_-SHDH ØDh5

Hexagon

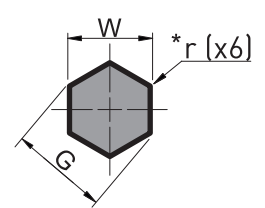

*Minimum Angle radius is r=0.15 by default
(If you want a radius of 2mm please specify r2)

Flat location on demand
Example : R2T0 Flat 1.5 x 5mm at 0°.



Alternate locations page 48



$$G = \sqrt{P^2 + W^2} ; G \leq A$$

Reference	Ø D	L				D_-S_DS	Others shapes		Ø Blank	Ø A Max
		20	25	32	35	ØP	W (min)	P / G (max)		
<p>Shapes</p> <p>Tol. ØD</p> <p>Material</p> <p>DA-SMDR</p> <p>B H F V H</p> <p>(TMY) = E</p> <p>(TMX) = T</p> <p>(SPECIALS) = X</p>	6	A+B	A+B			1,5 - 2,5	1,5	2,5	1	2,5
	8	A+B	A+B			1,5 - 3,5	1,5	3,5	1	3,5
	10	A+B	A+B	A+B		2 - 4,5	2	4,5	1,5	4,5
	13	A+B	A+B	A+B		2 - 6,7	2	6,7	1,5	6,7
	16	A+B	A+B	A+B	A+B	2,5 - 8,2	2,5	8,2	2	8,2
	20	A+B	A+B	A+B	A+B	2,5 - 10,7	2,5	10,7	2	10,7
	22	A+B	A+B	A+B	A+B	2,5 - 13	2,5	13	2	13
	25		A+B	A+B	A+B	2,5 - 16	2,5	16	2	16
	32			A+B		2,5 - 19,4	2,5	19,4	2	19,4
	38			A+B		2,5 - 23	2,5	23	2	23
	40			A+B		2,5 - 26,4	2,5	26,4	2	26,4
	45			A+B		2,5 - 27	2,5	27	2	27
	50			A+B		2,5 - 35,7	2,5	35,7	2	35,7

ØD and length "L" : Others dimensions on request. * Height H is 5mm by default

Material	Body	Head
A = (X155CrVMo.12.1)	58 - 62	40 - 50 HRc
B = (Z90 WDCV 06050402)	60 - 64	47 - 57 HRc

To order :

Die HWS	Straight Body (m5)	EDM	Blank	D body	L	Blank
DA-SMWB-16-25						
Die HWS	Straight Body (m5)	Tapered	Oblong	D body	L	H
DA-SMDL-16-25-5-P8.2-W5.2-PA1-R2-T0						

+ Other materials on request.
Other cutting shapes (E ; T ; X) : page 46
Available coatings : page 55
Technical options : page 48

D_-SMCB ØDm5
D_-SHCB ØDh5
Blank

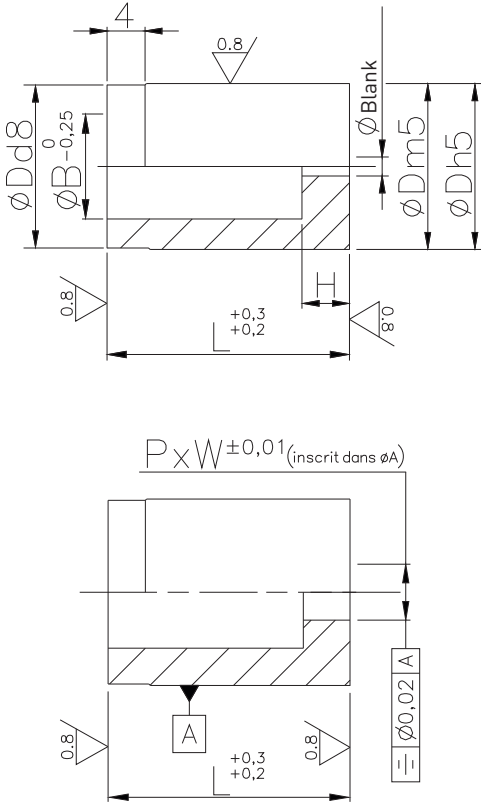

D_-SMCS ØDm5
D_-SHCS ØDh5
Round

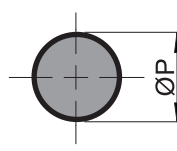

D_-SMCF ØDm5
D_-SHCF ØDh5
Rounded rectangle

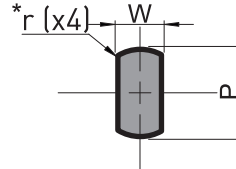

D_-SMCV ØDm5
D_-SHCV ØDh5
Square

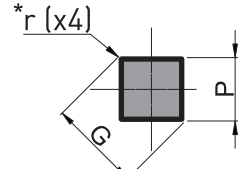

D_-SMCL ØDm5
D_-SHCL ØDh5
Oblong

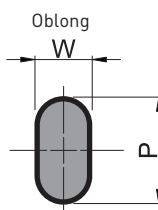

D_-SMCF ØDm5
D_-SHCF ØDh5
Rectangle

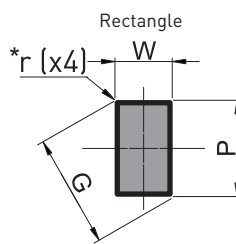

D_-SMCH ØDm5
D_-SHCH ØDh5
Hexagon

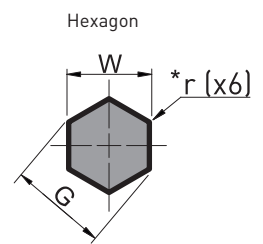

*Minimum Angle radius is r=0.15 by default
(If you want a radius of 2mm please specify r2)

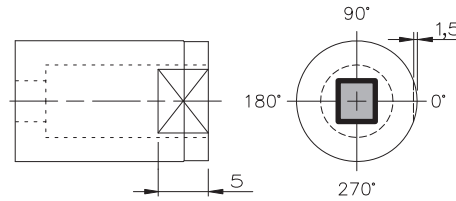

Flat location on demand
Example : R2T0 Flat 1.5 x 5mm at 0°.

Alternate locations page 48

! $G = \sqrt{P^2 + W^2}$; $G \leq A$

Reference	Ø D	L				H	D_-S_CS	Others shapes		Ø B	Ø E	Ø A Max
		20	25	32	35		ØP	W (min)	P / G (max)			
Shapes Tol. ØD Material DA - SMCR B H F V H (TMY) = E (TMX) = T (SPECIALS) = X	6	A+B	A+B			3	1,5 - 3	1,5	3	3,5	1	3
	8	A+B	A+B			4	1,5 - 3,5	1,5	3,5	4	1	3,5
	10	A+B	A+B	A+B		5 8	2 - 5,0	2	5	5,8	1,5	5
	13	A+B	A+B	A+B		5 8	2 - 7,0	2	7	8	1,5	7
	16	A+B	A+B	A+B	A+B	5 8	2,5 - 9,0	2,5	9	9,5	2	9
	20	A+B	A+B	A+B	A+B	5 8	2,5 - 11	2,5	11	12	2	11
	22	A+B	A+B	A+B	A+B	8	2,5 - 13	2,5	13	14	2	13
	25		A+B	A+B	A+B	5 8	2,5 - 16	2,5	16	17,3	2	16
	32			A+B		8	2,5 - 20	2,5	20	20,7	2	20
	38			A+B		8	2,5 - 26	2,5	26	27	2	26
	40			A+B		8	2,5 - 27	2,5	27	27,7	2	27
	45			A+B		8	2,5 - 35	2,5	35	36	2	35
	50			A+B		8	2,5 - 36	2,5	36	37	2	36

ØD and length "L" : Others dimensions on request. Height H applied by default others dimensions on request.

Material	Body	Head
A = (X155CrVMo.12.1)	58 - 62	40 - 50 HRc
B = (Z90 WDCV 06050402)	60 - 64	47 - 57 HRc

To order :

Die	HWS	Straight Body (rns)	Countersbore	Blank	D body	L	H	Blank			
DA - SMCB - 16 - 25 - 5											
Die	HWS	Straight Body (rns)	Tapered	Square	D body	L	H	Shape dimensions	Radius	Flat	Position
DA - SMCV - 16 - 25 - 5 - P6 - r1.5 - R2 - T90											

+ Other materials on request.
Other cutting shapes (E ; T ; X) : page 46
Available coatings : page 55
Technical options : page 48

D_-HMWB ØDm5
D_-HHWB ØDh5
Blank

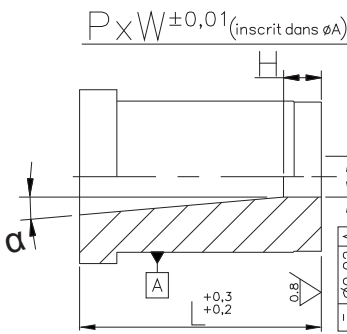
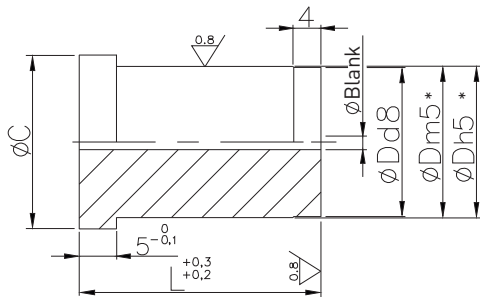

α = 1° by default
H = 5 by default

D_-HMDS ØDm5
D_-HHDS ØDh5
Round

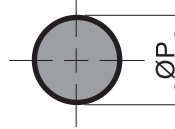

D_-HMDL ØDm5
D_-HHDL ØDh5
Oblong

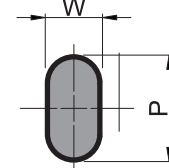

D_-HMDF ØDm5
D_-HHDF ØDh5
Rounded rectangle

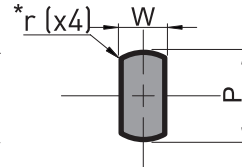

D_-HMDR ØDm5
D_-HHR ØDh5
Rectangle

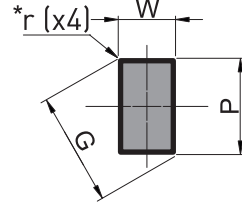

D_-HMDV ØDm5
D_-HHDV ØDh5
Square

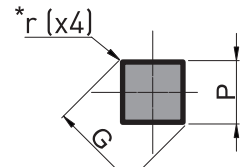

D_-HMDH ØDm5
D_-HHDH ØDh5
Hexagon

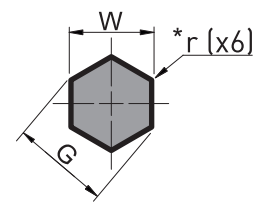

*Minimum Angle radius is r=0.15 by default
(If you want a radius of 2mm please specify r2)

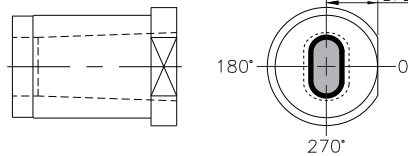

Flat location on demand
Example : R2T0 Flat 1.5 x 5mm at 0°.

Alternate locations page 48



$$G = \sqrt{P^2 + W^2} ; G \leq A$$

Reference	Ø D	L				D -H DS ØP	Others shapes		Ø C	Ø Blank	Ø A Max
		20	25	32	35		W (min)	P / G (max)			
Shapes Tol. ØD Material DA - HMDR B H F V H [TMY] = E [TMX] = T [SPECIALS] = X	6	A+B				1,5 - 2,5	1,5	2,5	9	1	2,5
	8	A+B	A+B			1,5 - 3,5	1,5	3,5	11	1	3,5
	10	A+B	A+B	A+B	A+B	2 - 4,5	2	4,5	13	1,5	4,5
	13	A+B	A+B	A+B	A+B	2 - 6,7	2	6,7	16	1,5	6,7
	16	A+B	A+B	A+B	A+B	2,5 - 8,2	2,5	8,2	19	2	8,2
	20	A+B	A+B	A+B	A+B	2,5 - 10,7	2,5	10,7	23	2	10,7
	22	A+B	A+B	A+B	A+B	2,5 - 13	2,5	13	25	2	13
	25		A+B	A+B	A+B	2,5 - 16	2,5	16	28	2	16
	32			A+B		2,5 - 19,4	2,5	19,4	35	2	19,4
	40			A+B		2,5 - 26,4	2,5	26,4	43	2	26,4
	50			A+B		2,5 - 35,7	2,5	35,7	53	2	35,7

ØD and length "L" : Others dimensions on request.

* Height H is 5mm by default

Material	Body	Head
A = (X155CrVMo.12.1)	58 - 62	40 - 50 HRc
B = (Z90 WDCV 06050402)	60 - 64	47 - 57 HRc

To order :

Die HWS	Headed Body (InS)	EDM	Blank	D body	L	Blank
DA - HMWB - 20 - 25						
Die HWS	Headed Body (InS)	Tapered	Oblong	D body	L	H
DA - HMDL - 20 - 25 - 5 - P8 - W5 - PA2 - R2 - T0						
						Shape dimensions
						Relief 2°
						Flat
						Position

+ Other materials on request.
Other cutting shapes (E ; T ; X) : page 46
Available coatings : page 55
Technical options : page 48

D_-HM CB ØDm5
D_-HH CB ØDh5
Blank

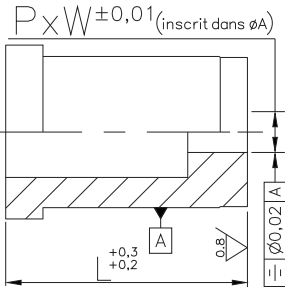
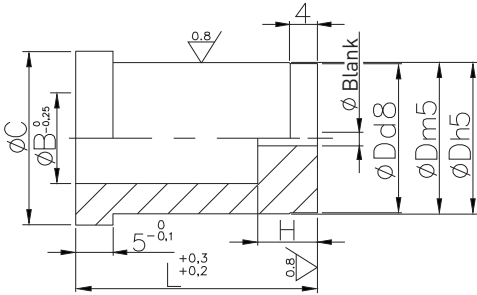

D_-HM CS ØDm5
D_-HH CS ØDh5
Round

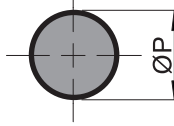

D_-HM CL ØDm5
D_-HH CL ØDh5
Oblong

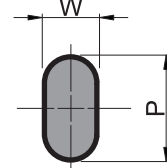

D_-HM CF ØDm5
D_-HH CF ØDh5
Rounded rectangle

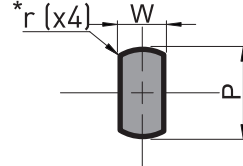

D_-HM CR ØDm5
D_-HH CR ØDh5
Rectangle

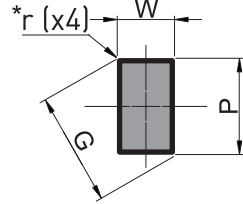

D_-HM CV ØDm5
D_-HH CV ØDh5
Square

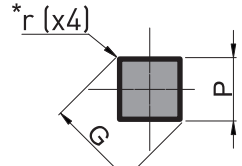

D_-HM CH ØDm5
D_-HH CH ØDh5
Hexagon

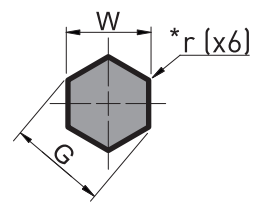

*Minimum Angle radius is r=0.15 by default
(If you want a radius of 2mm please specify r2)

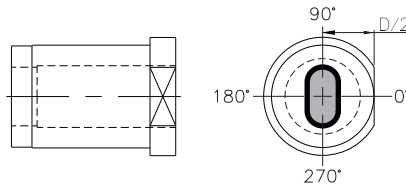

Flat location on demand
Example : R2T0 Flat 1.5 x 5mm at 0°.



$$G = \sqrt{P^2 + W^2} ; G \leq A$$

Alternate locations page 48

Reference	Ø D	L				H	D_-H_CS		Others shapes		Ø E	Ø C	Ø B	Ø A Max
		20	25	32	35		Ø P	W (min)	P / G (max)					
Shapes Tol. ØD Material DA - HM CR B H F V H (TMY) = E (TMX) = T (SPECIALS) = X	6	A+B				3	1,5 - 3	1,5	3	1	9	3,5	3	
	8	A+B	A+B			4	1,5 - 3,5	1,5	3,5	1	11	4	3,5	
	10	A+B	A+B	A+B	A+B	5 8	2 - 5,0	2	5	1,5	13	5,8	5	
	13	A+B	A+B	A+B	A+B	5 8	2 - 7,0	2	7	1,5	16	8	7	
	16	A+B	A+B	A+B	A+B	5 8	2,5 - 9,0	2,5	9	2	19	9,5	9	
	20	A+B	A+B	A+B	A+B	5 8	2,5 - 11	2,5	11	2	23	12	11	
	22	A+B	A+B	A+B	A+B	8	2,5 - 13	2,5	13	2	25	14	13	
	25		A+B	A+B	A+B	5 8	2,5 - 16	2,5	16	2	28	17,3	16	
	32			A+B		8	2,5 - 20	2,5	20	2	35	20,7	20	
	40			A+B		8	2,5 - 27	2,5	27	2	43	27,7	27	
50			A+B		8	2,5 - 36	2,5	36	2	53	37	36		

ØD and length "L" : Others dimensions on request. Height H applied by default others dimensions on request.

Material	Body	Head
A = (X155CrVMo.12.1)	58 - 62	40 - 50 HRc
B = (Z90 WDCV 06050402)	60 - 64	47 - 57 HRc

To order :

Die HWS Headed Body (min) Counterbore Blank D.body L H
DA - HM CB - 16 - 25 - 5

Die HWS Headed Body (min) Counterbore Oblong D.body L H Shape dimensions Flat Position
DA - HM CL - 16 - 25 - 5 - P8.2 - W5.2 - R2 - T90

+ Other materials on request.
 Other cutting shapes (E ; T ; X) : page 46
 Available coatings : page 55
 Technical options : page 48

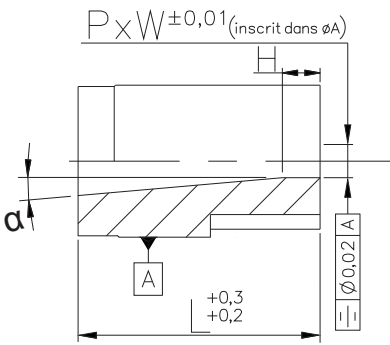
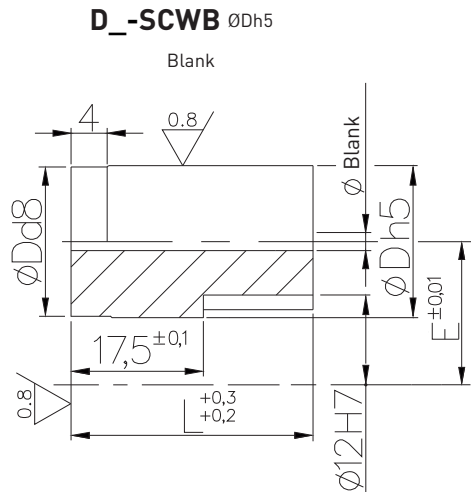

$\alpha = 1^\circ$ by default
H = 5 by default

! $G = \sqrt{P^2 + W^2}$; $G \leq A$

D_-SCDS ØDh5
Round

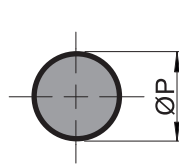

D_-SCDF ØDh5
Rounded rectangle

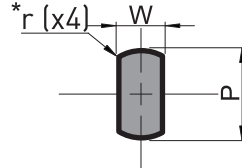

D_-SCDV ØDh5
Square

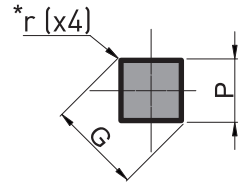

D_-SCDL ØDh5
Oblong

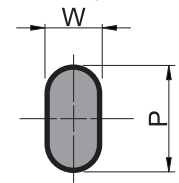

D_-SCDR ØDh5
Rectangle

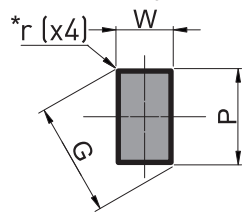

D_-SCDH ØDh5
Hexagon

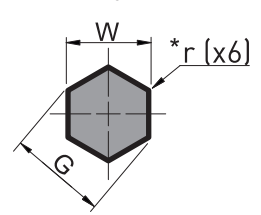

*Minimum Angle radius is $r=0.15$ by default
(If you want a radius of 2mm please specify r2)

Possible die mounting

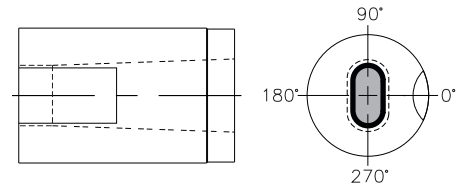
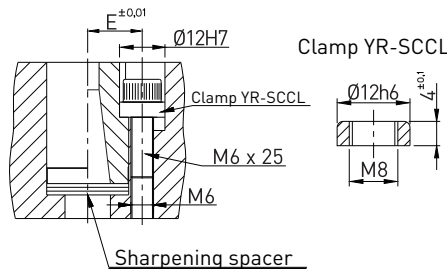

! Shape is made at $T=0^\circ$ by default as per drawing above

+ Sharpening spacers page 32
Mounting accessories page 31

Reference	Ø D	L		D_-SCDS		Others shapes		E	Ø Blank	Ø A Max
		32		ØP		W (min)	P / G (max)			
Shapes Material DA - SCDR K (TMY) = E (TMX) = T (SPECIALS) = X	16	A+K		2,5 - 8,2		2,5	8,2	11,5	2	8,2
	20	A+K		2,5 - 10,7		2,5	10,7	13,5	2	10,7
	25	A+K		2,5 - 16		2,5	16	16	2	16
	32	A+K		2,5 - 19,4		2,5	19,4	19,5	2	19,4
	40	A+K		2,5 - 26,4		2,5	26,4	23,5	2	26,4
	50	A+K		2,5 - 35,7		2,5	35,7	28,5	2	35,7
ØD and length "L" : Others dimensions on request.										* Height H is 5mm by default

Material	Body
A = (X155CrVMo.12.1)	58 - 62 HRc
K = (X110CrMoV8-T6)	62 - 66 HRc

+ Other materials on request.
Other cutting shapes (E ; T ; X) : page 46
Available coatings : page 55
Technical options : page 48

To order :

Die	HWS	Key located	Body (H5)	EDM	Blank	D body	L					
DA - SCWB - 20 - 32												
Die	HWS	Key located	Body (H5)	Tapered	Oblong	D body	L	H	Shape dimensions	Relief 1°	Shaped	Position
DA - SCDL - 20 - 32 - 5 - P7.2 - W5.2 - PA1 - T0												

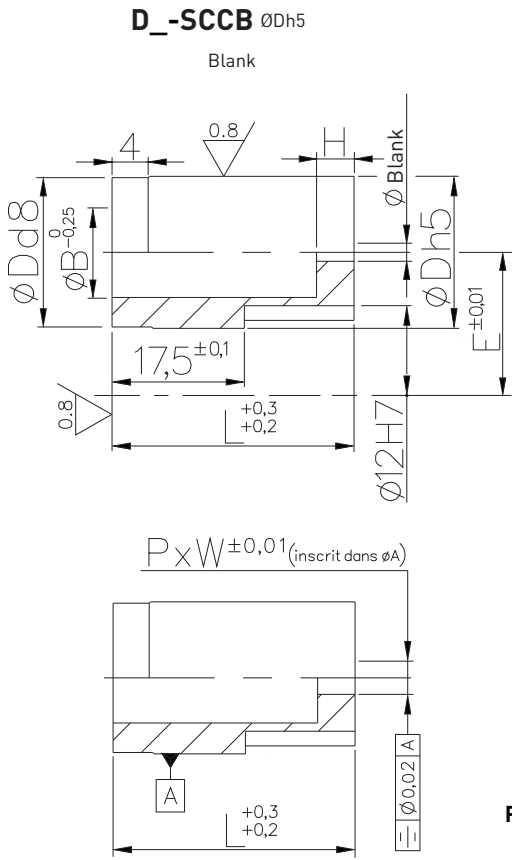

! $G = \sqrt{P^2 + W^2}$; $G \leq A$

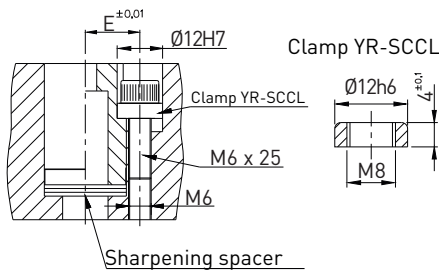

D_-SCCS $\varnothing Dh5$
Round

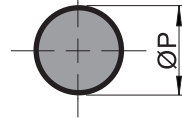

D_-SCCL $\varnothing Dh5$
Oblong

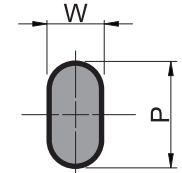

D_-SCCF $\varnothing Dh5$
Rounded rectangle

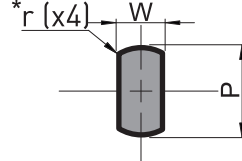

D_-SCCR $\varnothing Dh5$
Rectangle

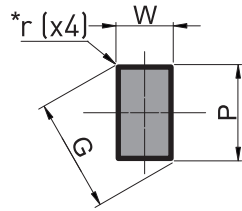

D_-SCCV $\varnothing Dh5$
Square

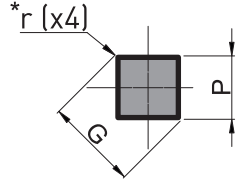

D_-SCCH $\varnothing Dh5$
Hexagon

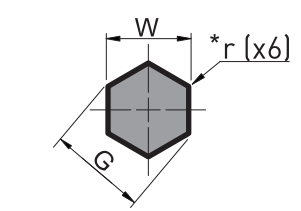

*Minimum Angle radius is $r=0.15$ by default
(If you want a radius of 2mm please specify r2)

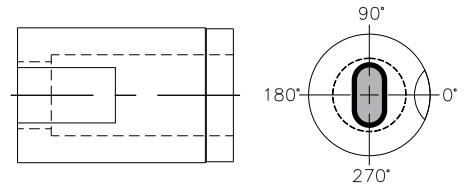

Shape is made at T=0° by default as per drawing above



**Sharpening spacers page 32
Mounting accessories page 31**

Reference	$\varnothing D$	L 32	H		D_-SCCS			Others shapes		$\varnothing B$	E	$\varnothing A$	$\varnothing \text{Blank}$
					$\varnothing P$	W (min)	P / G (max)						
Shapes Material DA - SCCR K (TMY) = E (TMX) = T (SPECIALS) = X	16	A+K	5	8	2,5 - 9,0	2,5	9	9,5	11,5	9	2		
	20	A+K	5	8	2,5 - 11	2,5	11	12	13,5	11	2		
	25	A+K	5	8	2,5 - 16	2,5	16	17,3	16	16	2		
	32	A+K	5	8	2,5 - 20	2,5	20	20,7	19,5	20	2		
	40	A+K	5	8	2,5 - 27	2,5	27	27,7	23,5	27	2		
	50	A+K	5	8	2,5 - 36	2,5	36	37	28,5	36	2		

$\varnothing D$ and length "L" : Others dimensions on request. Height H applied by default others dimensions on request.

Material	Body
A = (X155CrVMo.12.1)	58 - 62 HRc
K = (X110CrMoV8-T6)	62 - 66 HRc

To order :

Die HWS Key located Body (H5) Counter-bore Blank D.body L H
DA - S C C B - 20 - 32 - 5

Die HWS Key located Body (H5) Counter-bore Oblong D.body L H Shape dimensions Position
DA - S C C L - 20 - 32 - 5 - P8.2 - W5.2 - T0

+ **Other materials on request.**
Other cutting shapes (E ; T ; X) : page 46
Available coatings : page 55
Technical options : page 48

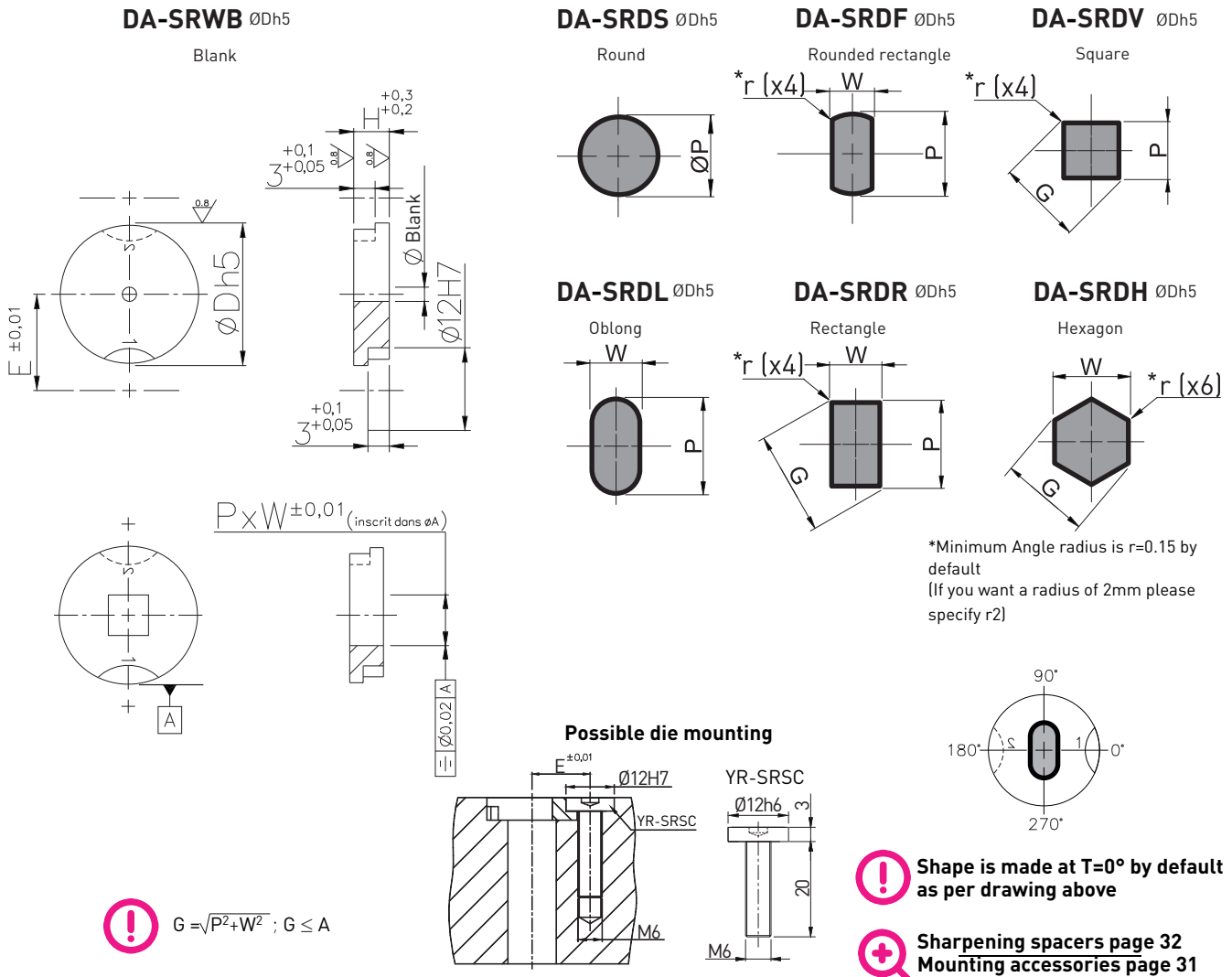

Reference	Ø D	H			DA-SRDS		Others shapes		E	Ø Blank	Ø A
					Ø P	W (min)	P / G (max)				
Shapes Material DA-SRDR (TMY) = E (TMX) = T (SPECIALS) = X	13	5	8		2,5 - 7,0	2	7	10,5	1,5	7	
	16	5	8	10	2,5 - 9,0	2,5	9	11,5	2	9	
	20	5	8	10	2,5 - 11	2,5	11	13,5	2	11	
	25	5	8	10	2,5 - 16	2,5	16	16	2	16	
	32	5	8	10	2,5 - 20	2,5	20	19,5	2	20	
	40	5	8		2,5 - 27	2,5	27	23,5	2	27	
	50	5	8		2,5 - 36	2,5	36	28,5	2	36	
ØD and length "L" : Others dimensions on request.					□ Height H applied by default others dimensions on request.						

Material	Body
A = [X155CrVMo.12.1]	58 - 62 HRc

+ Other materials on request.
Other cutting shapes (E ; T ; X) : page 46
Available coatings : page 55
Technical options : page 48

To order :

Die HW/S Reversible Blank D.body H
DA-SRWB-20-5

Die HW/S Reversible Rectangle D.body H Shape dimensions Radius Position
DA-SRDR-20-5-P8.2-W5.2-r1.2-T90

D_-SSWB ØDh5

Blank

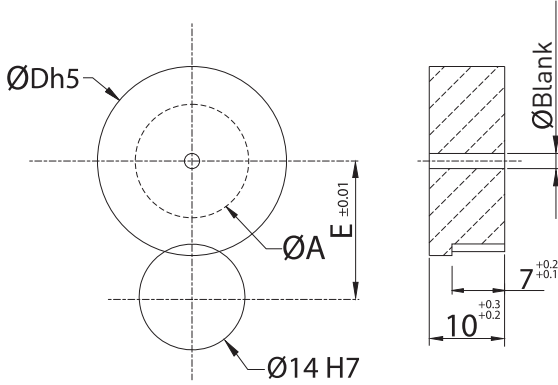

Clamp YR-SCCL

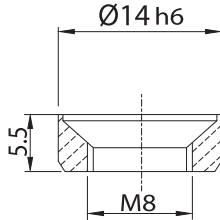

D_-SSDS ØDh5

Round

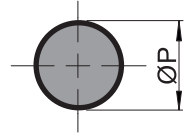

D_-SSDF ØDh5

Rounded rectangle

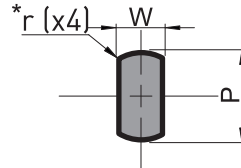

D_-SSDV ØDh5

Square

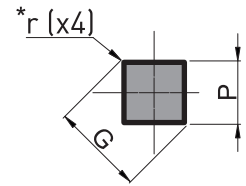

D_-SSDL ØDh5

Oblong

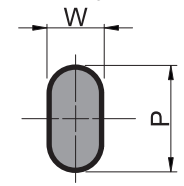

D_-SSDR ØDh5

Rectangle

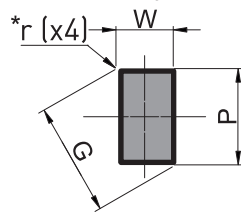

D_-SSDH ØDh5

Hexagon

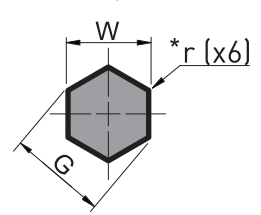

*Minimum Angle radius is r=0.15 by default
(If you want a radius of 2mm please specify r2)



**Fastened by screw M6 (FHC)
M8 screw extraction**

Not supplied

Clamp YR-SSCL : page 31

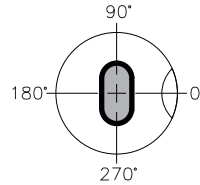

**Shape is made at T=0° by default
as per drawing above**

Reference	Ø D	Ø E	Ø Blank	Ø A Max
13	13	11,5	1,5	7
16	16	12,5	2	9
20	20	14	2	10
25	25	16,5	2	15
32	32	20	2	19
40	40	24,5	2	27
50	50	29,5	2	36

Material: **DA-SSDR**

Shapes: S, L, F, V, H, E, T, X

(TMY) = E, (TMX) = T, (SPECIALS) = X

Material	Body
A = (X155CrVMo.12.1)	58 - 62 HRc
K = (X110CrMoV8-T6)	62 - 66 HRc



**Other materials on request.
Other cutting shapes (E ; T ; X) : page 46**

**Available coatings : page 55
Technical options : page 48**

To order :

Die HWS	No - Reversible	Blank	D.body	H	Blank
DA-SSWB-25-10					
Die HWS	No - Reversible	Oblong	D.body	H	Shaped
DA-SSDL-25-10-P8.2-W5.2-T90					

DA-BLCB ØDg5

Blank

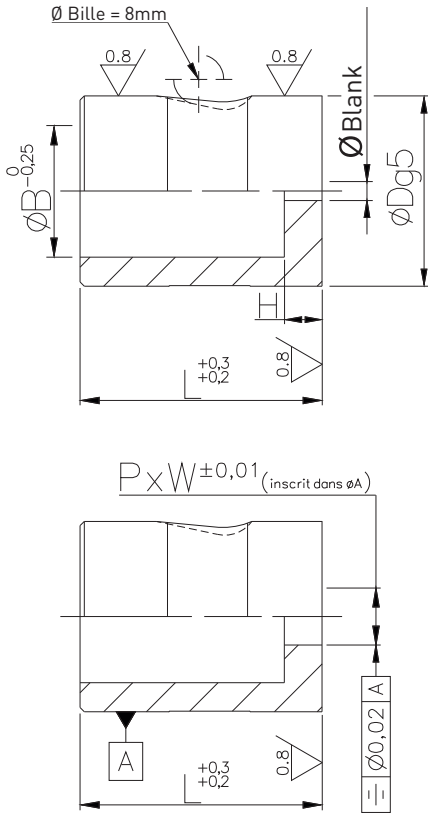

$P \times W \pm 0,01$ (inscrit dans ØA)

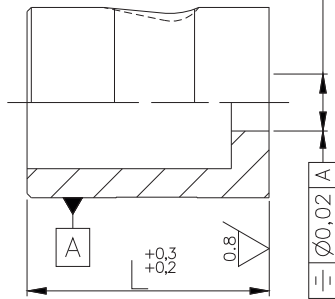

$$G = \sqrt{P^2 + W^2} ; G \leq A$$

DA-BLCS ØDg5

Round

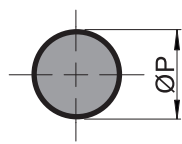

DA-BLCF ØDg5

Rounded rectangle

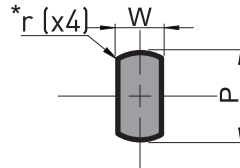

DA-BLCV ØDg5

Square

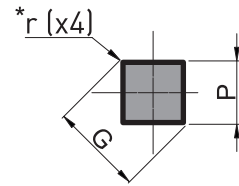

DA-BLCL ØDg5

Oblong

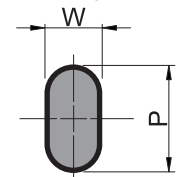

DA-BLCR ØDg5

Rectangle

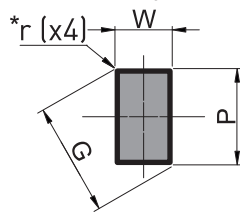

DA-BLCH ØDg5

Hexagon

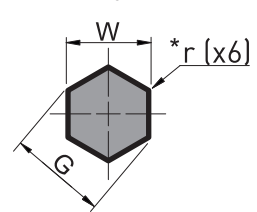

*Angle radius is r=0 by default
(If you want a radius of 1.5mm please specify r1.5)

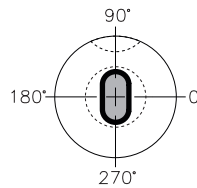

Shape made by default at T=90° from the ball seat as shown in the drawings following drawing opposite

Reference	Ø D	L	H	DA-BLCS		Others shapes		Ø B	Ø Blank	Ø A
		32		ØP	W (min)	P / G (max)				
<p>Shapes</p> <ul style="list-style-type: none"> S L DA - BLCR F V H <p>(TMY) = E (TMX) = T (SPECIALS) = X</p>	13	A	5	2-5,5	2	5,5	6,5	1,5	5,5	
	16	A	5	2,5-6,9	2,5	6,9	8	2	9	
	20	A	5	2,5 - 11	2,5	11	12	2	11	
	25	A	5	2,5-16,3	2,5	16,3	17,5	2	16	
	32	A	5	2,5 - 20,5	2,5	20,5	21,5	2	20	
	40	A	5	2,5 - 27	2,5	27	28	2	27	

ØD and length "L" : Others dimensions on request. Height H applied by default others dimensions on request.

Material	Body
A = [X155CrVMo.12.1]	58 - 62 HRc

+ Other materials on request.
Other cutting shapes (E ; T ; X) : page 46
Available coatings : page 55
Technical options : page 48

To order :

Die HWS	Ball-lock	Counter-bore	Blank	D.body	L	H	Blank
DA - BLCB - 20 - 32 - 5							
Die HWS	Ball-lock	Counter-bore	Oblong	D.body	L	H	Shaped
DA - BLC L - 20 - 32 - 5 - P8.2 - W5.2 - T90							

Fastening of key located dies button :

DIE BUTTON D_-SCC_

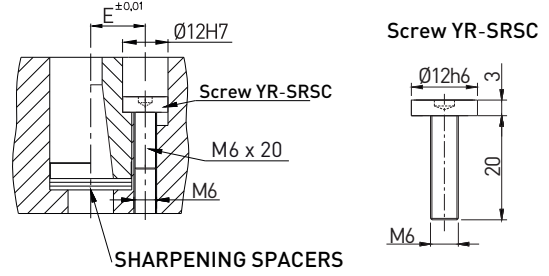
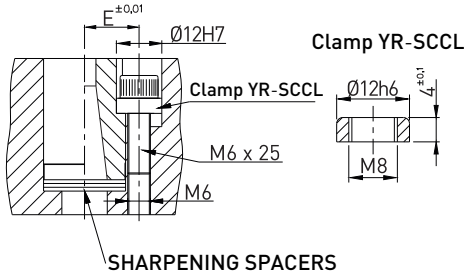

DIE BUTTON D_-SR_

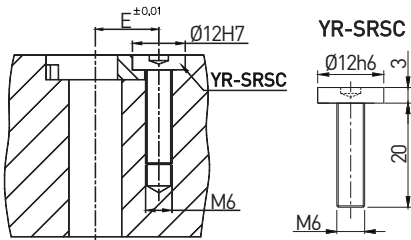

DIE BUTTON D_-SR_

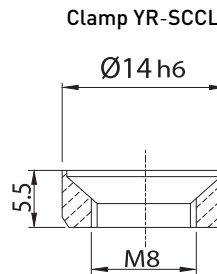

Fastened by screw M6 (FHC)
M8 screw extraction
Not supplied

Fitting of tapered head punches :

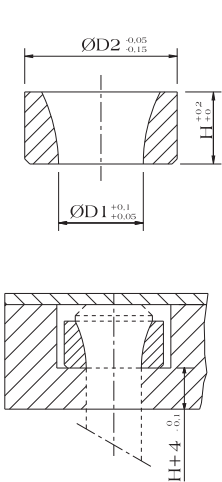

Seat for tapered head punches.

Reference	Ø D1	Ø D2	H
	5	12	6
	6	13	7
	8	16	8
	10	20	9
	13	25	9
	16	32	9
	20	32	10

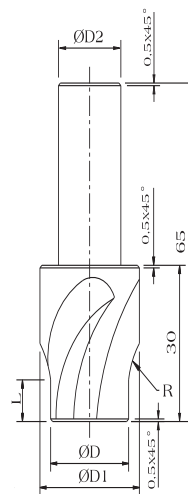

Machining tool for the housing of tapered head punches
Material : High speed = B
Material : Carbure = C

Reference	Ø Df7	Ø D1	Ø D2	R	L
Material	5	7,4	8	10	5
	6	9,5	8	10	5
	8	11,5	8	12	5
	10	14,5	10	15	8
	13	17,5	10	15	8
	16	20,5	10	15	8
	20	25,5	16	15	8

Punch retainers for tapered head punches are available on request page 37.
Standard tapered head punches page 12
Others dimensions on request

To order :

Qty = 15 ; for punches ØD = 10 mm
15 YR-RFSE-10

To order :

Qty = 1 ; ØD = 10 mm in high speed steel
1 YB-RFMT-10

FOR HEADLESS DIE BUTTON
D_-SMC_/D_-SMC_/DA-SCC_
YF-SACB series

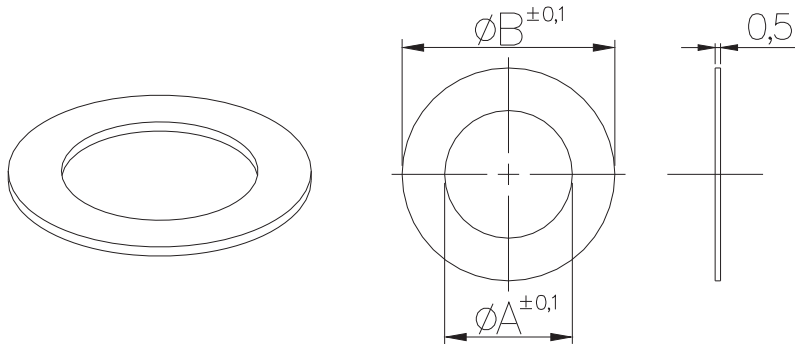

To order :

Qty = 3 ; for die button ØD = 20 mm
3 YF-SACB-20

Reference	Ø D Die button	Ø A	Ø B
YF-SACB (XC70 (1.1249))	10	6	9,7
	13	8	12,7
	16	10	15,7
	20	12,5	19,7
	25	18	24,7
	32	21,5	31,7
	40	28,5	39,7
	50	37,5	49,7

FOR HEADED DIE BUTTON
D_-HMC_/D_-HHC_
YF-SACA series

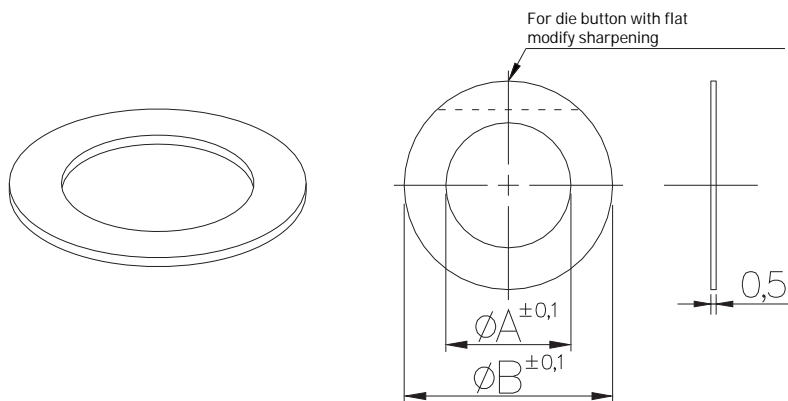

To order :

Qty = 3 ; for die button ØD = 20 mm
3 YF-SACA-20

Reference	Ø D Die button	Ø A	Ø B
YF-SACB (XC70 (1.1249))	10	6,5	13,7
	13	8,5	16,7
	16	10	19,7
	20	12,5	23,7
	25	18	38,7
	32	21,5	35,7
	40	28,5	43,7
	50	37,5	53,7

French patent
REF.1.454.836



Available material
Polyuréthane 90 Shore

To order :

Qty = 2 ; for die button ØD = 16 mm x L = 45mm
3 YU-SSCR-16-45

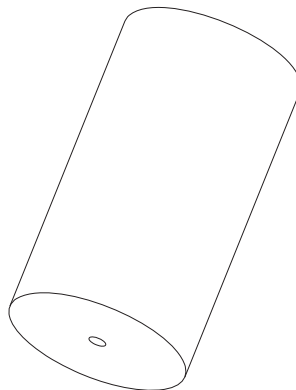

YU-SSCR series

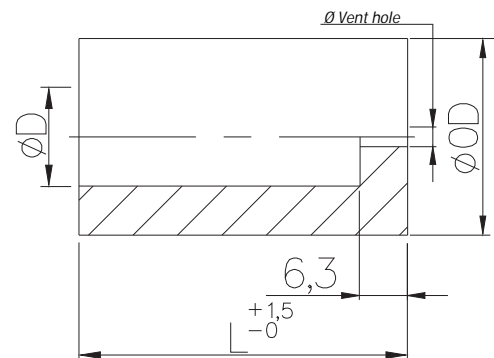

Reference	Ø D (mm)	Ø OD (mm)	L (mm)	Ø Vent hole	Approx stripping pressure (in daN) with distortion of :		
					3mm	6,5mm	9,5mm
* YU-SSCR-5-55	5	18	35	1,6	125	200	
			45		115	175	
			55		105	150	
* YU-SSCR-6-65	6	19	35	1,6	140	240	
			45		135	230	
			55		110	190	240
			65		90	130	200
* YU-SSCR-8-75	8	21	35	1,6	160	250	
			45		150	225	
			55		135	200	300
			65		120	185	290
* YU-SSCR-10-75	10	23	35	2,5	160	270	
			45		175	285	
			47		160	270	
			55		145	250	325
			65		130	220	290
* YU-SSCR-13-75	13	26	35	3	210	350	
			38		190	310	
			45		175	285	
			47		165	270	
			55		150	240	300
			65		130	200	250
* YU-SSCR-16-75	16	30	35	3	260	390	
			38		225	360	
			45		215	340	
			47		165	270	
			55		150	240	300
			65		130	200	250
			75		105	160	200
* YU-SSCR-20-75	20	38	35	3	300	460	
			38		260	420	
			45		240	390	
			47		235	385	
			55		220	360	460
			65		200	330	420
* YU-SSCR-25-75	25	50	38	3	280	420	
			47		240	390	
			55		200	350	550
			65		165	300	450
			75		150	270	400
* YU-SSCR-25-75	25	50	35	3	1200	1800	
			38		1100	1600	
			45		1000	1500	
			47		900	1400	
			55		700	1150	1650
			65		600	1000	1450
			75		500	850	1300

*Intermediate length L



RR-PPTS

For round shaped punches

RR-PPTF

For shaped punches

Ø D	C ±0,10	
	RR-PPTS	RR-PPTF
8	12	10
10	14	12,3
13	17	15
16	20	18
20	25	22,5
25	30	27,8
32	37	34

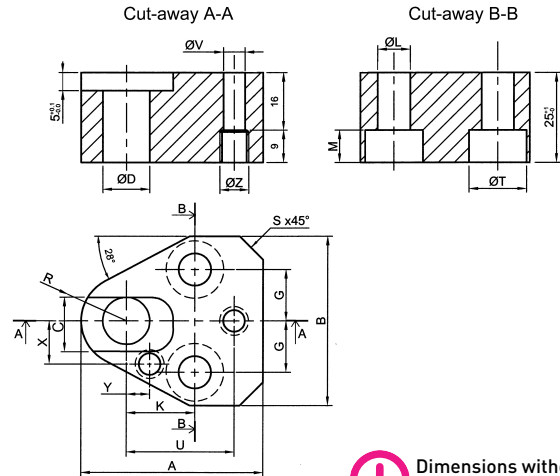
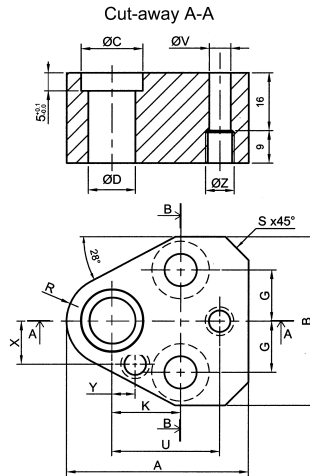

! Dimensions without tolerance ±0,25 mm.

Reference	ØD	A	B	R	S	G	K	Y	U	X	V	L	T	M	Z
	G6	±0,25	±0,25	±0,25	±0,25	±0,10	±0,10	±0,01	±0,01	±0,01	G6	H12	H13	±0,25	
Serie RR-PPTS F	8	44,3	41	9,5	5	11,12	19,05	7,5	26,92	9	6	9	16	9	M8
	10	44,3	41	9,5	5	11,12	19,05	7,5	26,92	9	6	9	16	9	M8
	13	50,4	47	12,5	7,5	14,27	19,05	6,5	29,97	12	6	9	16	9	M8
	16	53,5	50	14	8,5	15,87	19,05	6	31,75	13,5	6	9	16	9	M8
	20	60,1	55	17,4	10	17,47	19,05	5	33,53	16,5	6	11	18	11	M8
	25	69,7	63	22	12	19,84	23,82	7	40,64	22	6	14	20	13	M8
	32	69,7	63	22	12	19,84	23,82	7	40,64	22	6	14	20	13	M8

To order :

Punch retainers without shock plate

Qty = 3 RR-PPT

Shock plate :

ØD (punch)	H=4,8	H=5,8
	8	RR-BPTT-8-4,8
10	RR-BPTT-10-4,8	RR-BPTT-10-5,8
13	RR-BPTT-13-4,8	RR-BPTT-13-5,8
16	RR-BPTT-16-4,8	RR-BPTT-16-5,8
20	RR-BPTT-20-4,8	RR-BPTT-20-5,8
25	RR-BPTT-25-4,8	RR-BPTT-25-5,8
32	RR-BPTT-32-4,8	RR-BPTT-32-5,8

Material	Hardness
Punch retainer	43 - 48 HRc
Shock plate {40CrMo8 T4 / 4140T}	32 - 38 HRc

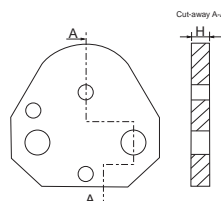

To order :

Shock plate

Qty = 3 RR-BPTT-16-4,8



RR-PPVS

For round shaped punches

RR-PPVF

For shaped punches

Ø D	Ø C RR-PPVS	C RR-PPVF
8	12	10
10	14,5	12,3
13	18,5	15,8
16	20,5	18,3
20	25,5	22,8
25	30,5	27,8
32	38,5	35,3

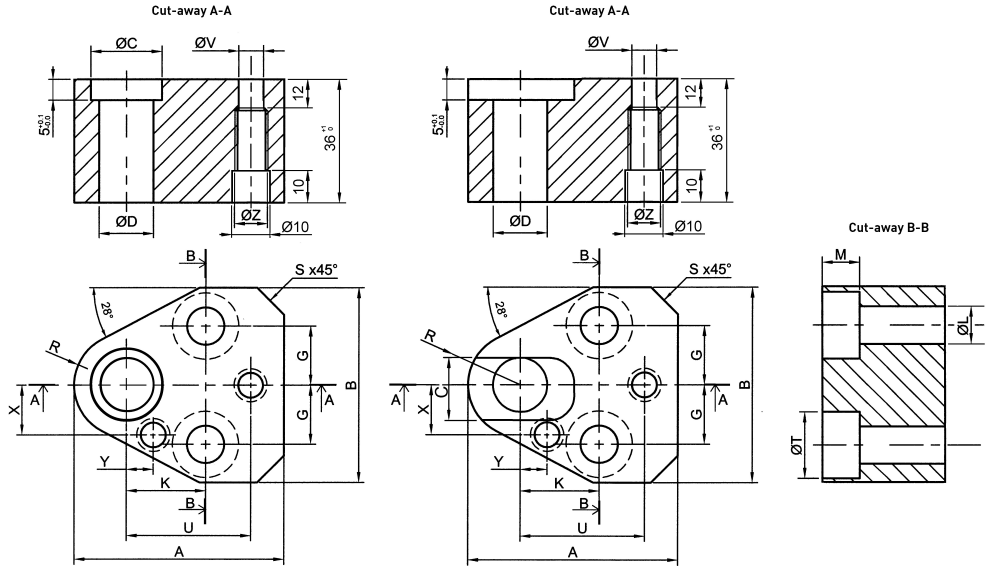

Reference	ØD	A	B	R	S	G	K	Y	U ±0,01	X ±0,01	V Ø6	L	T	M	a°
Serie RR-PPVS F	8	44,3	41	9,5	5	11,12	19,05	7,5	26,92	9	6	9	16	9	30
	10	44,3	41	9,5	5	11,12	19,05	7,5	26,92	9	6	9	16	9	30
	13	50,4	47	12,5	7,5	14,27	19,05	6,5	29,97	12	6	9	16	9	28
	16	53,5	50	14	8,5	15,87	19,05	6	31,75	13,5	6	9	16	9	28
	20	60,1	55	17,5	10	17,47	19,05	5	33,53	16,5	6	11	18	11	28
	25	69,7	63	22	12	19,84	23,82	7	40,64	22	6	14	20	13	28
	32	69,7	63	22	12	19,84	23,82	7	40,64	22	6	14	20	13	28

To order :

Punch retainers without shock plate

Qty = 3 RR-PPVS-20

Shock plate :

ØD (punch)	H=4,8	H=5,8
8	RR-BPTT-8-4,8	RR-BPTT-8-5,8
10	RR-BPTT-10-4,8	RR-BPTT-10-5,8
13	RR-BPTT-13-4,8	RR-BPTT-13-5,8
16	RR-BPTT-16-4,8	RR-BPTT-16-5,8
20	RR-BPTT-20-4,8	RR-BPTT-20-5,8
25	RR-BPTT-25-4,8	RR-BPTT-25-5,8
32	RR-BPTT-32-4,8	RR-BPTT-32-5,8

Material	Hardness
Punch retainer	43 - 48 HRc
Shock plate {40CrMo8 T4 / 4140T}	32 - 38 HRc

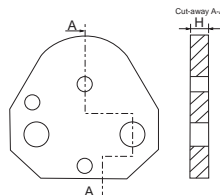

To order :

Shock plate

Qty = 3 RR-BPTT-16-4.8

NEW

RR-PTHS

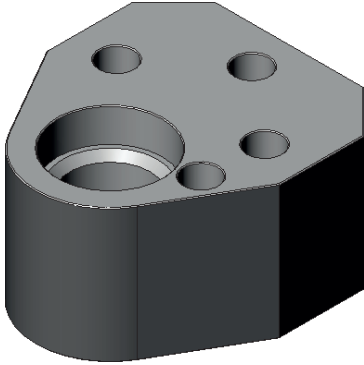

RR-PTHS

For round shaped punches

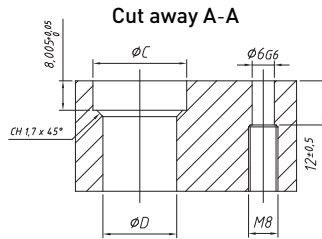

RR-PTHF

For shaped punches

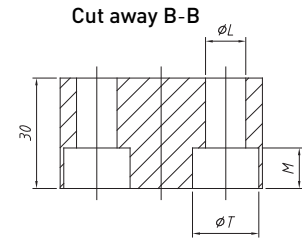

RR-PTHF

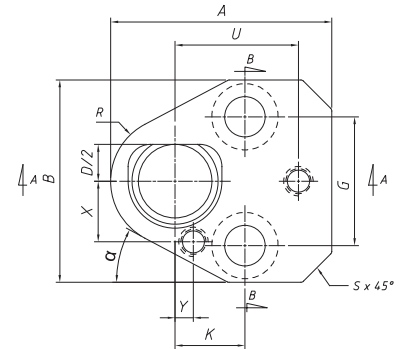
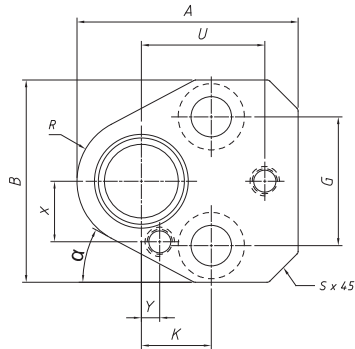
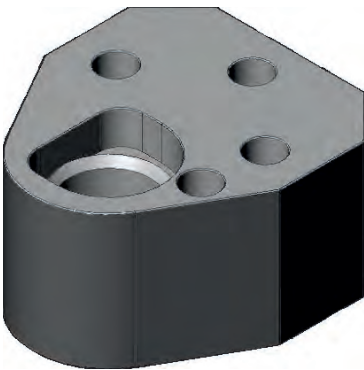

Reference	ØD	C	A	B	R	S	G	K	Y	U	X	L	T	M	a°
	G6	±0,10	±0,25	±0,25	±0,25	±0,25	±0,10	±0,10	±0,01	±0,01	±0,01	H12	H13	±0,25	
Serie ↓ RR-PTHS F	10	15,5	44,5	43,7	9,5	12	22,2	19	7,5	26,92	9	9	14,5	9	30
	13	18,5	50,8	50	12,7	15,2	28,6	19	6,5	29,97	12	9	14,5	9	28
	16	21,5	54	53,2	14,3	16,8	31,8	19	6	31,75	13,5	9	14,5	9	28
	20	25,5	60,3	59,5	17,5	20	35	19	5	33,53	16,5	11	18,5	11	28
	25	30,5	69,9	69,1	22,2	24,7	39,6	23,8	7	40,64	22	14	16,5	13	28

To order :

Punch retainers without shock plate

Qty = 3 RR-PTHS - 20

Shock plate :

ØD (punch)	H=4,8	H=5,8
8	RR-BPHT-8-4,8	RR-BPHT-8-5,8
10	RR-BPHT-10-4,8	RR-BPHT-10-5,8
13	RR-BPHT-13-4,8	RR-BPHT-13-5,8
16	RR-BPHT-16-4,8	RR-BPHT-16-5,8
20	RR-BPHT-20-4,8	RR-BPHT-20-5,8
25	RR-BPHT-25-4,8	RR-BPHT-25-5,8
32	RR-BPHT-32-4,8	RR-BPHT-32-5,8

Material	Hardness
Punch retainer	43 - 48 HRc
Shock plate {40CMD8 T4 / 4140T}	32 - 38 HRc

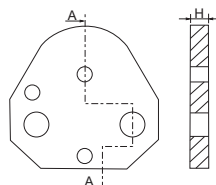

To order :

Shock plate

Qty = 3 RR-BPHT - 16 - 4.8

RR-RFFS

For round shaped punches

Cut away A-A

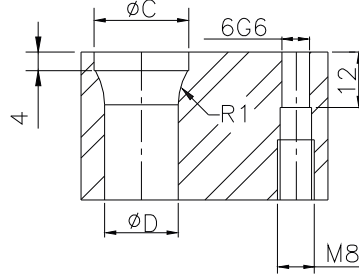

Cut away B-B

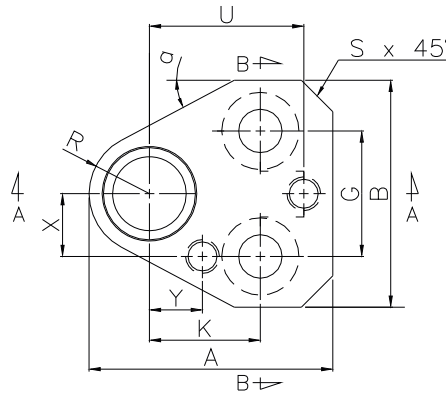
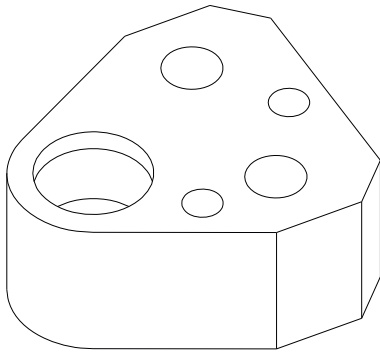
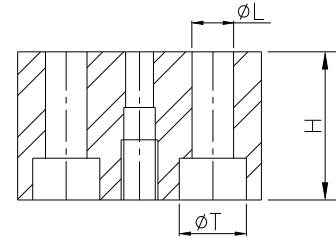

Reference	ØD K6	C ±0,25	A ±0,25	B ±0,25	H	R ±0,25	S ±0,25	G ±0,25	K ±0,25	Y ±0,01	U ±0,01	X ±0,01	L H13	T H13	M ±0,25	a°
RR-RFFS	6	9,5	35	37,5	25	8	5	11,1	19	9	23	8	7	12	9	30
	8	11,5	44,3	41	25	9,5	5	11,12	19,05	7,5	26,92	9	9	16	9	30
	10	14,5	44,3	41	32	9,5	5	11,12	19,05	7,5	26,92	9	9	16	9	30
	13	17,5	50,4	47	32	12,5	7,5	14,27	19,05	6,5	29,97	12	9	16	9	28
	16	20,5	53,5	50	32	14	8,5	15,87	19,05	6	31,75	13,5	9	16	9	28
	20	25,5	60,1	55	41	17,5	10	17,47	19,05	5	33,53	16,5	11	18	11	28
	25	30,5	69,7	63	41	22	12	19,84	23,82	7	40,64	22	14	20	13	28

To order :

Punch retainers without shock plate

Qty = 3 RR - RFFS - 20

Shock plate :

ØD (punch)	H=4,8	H=5,8
8	RR-BPTT-8-4,8	RR-BPTT-8-5,8
10	RR-BPTT-10-4,8	RR-BPTT-10-5,8
13	RR-BPTT-13-4,8	RR-BPTT-13-5,8
16	RR-BPTT-16-4,8	RR-BPTT-16-5,8
20	RR-BPTT-20-4,8	RR-BPTT-20-5,8
25	RR-BPTT-25-4,8	RR-BPTT-25-5,8
32	RR-BPTT-32-4,8	RR-BPTT-32-5,8

Material	Hardness
Punch retainer	43 - 48 HRc
Shock plate {40CMD8 T4 / 4140T}	32 - 38 HRc

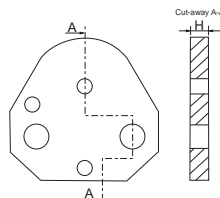

To order :

Shock plate

Qty = 3 RR - BPTT - 16 - 4.8

RR-BLTN

Light duty height = 32mm

RR-BHTN

Heavy duty height = 41mm



Cut away A-A

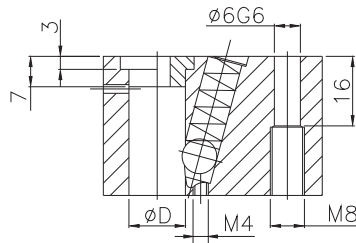

Cut away B-B

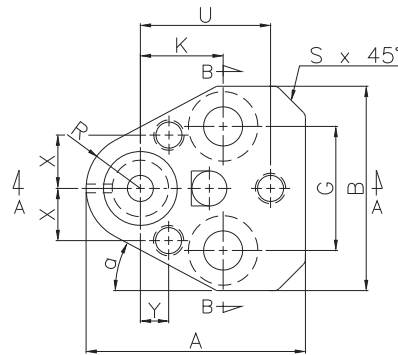
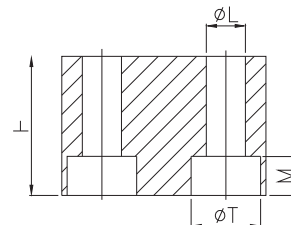

Ball-lock release tool



YZ-BLRT

Ref	ØD H6	Ø Ball	A ±0,25	B ±0,25	H ^{+1/0}	L ^{+0,3}	U ±0,01	Y ±0,01	K ±0,1	G ±0,2	X ±0,01	M ±0,2	T ^{+0,3}	R ±0,25	S	a°
LIGHT DUTY																
RR-BLTN	10	8	44,3	41	32	9	26,924	7,5	19,05	22,24	9	9	16	9,5	5	30
	13	8	50,4	47	32	9	29,972	6,5	19,05	28,54	12	9	16	12,5	6,5	28
	16	8	53,5	50	32	9	31,75	6	19,05	31,74	13,5	9	16	14,5	7	28
	20	8	60,1	55	32	11	33,528	5	19,05	34,94	16,5	11	18	17,4	8	28
	25	8	69,7	63	32	14	40,64	7	23,82	39,68	22	13	20	22,2	9	28
HEAVY DUTY																
RR-BHTN	10	10	44,3	41	41	9	26,924	7,5	19,05	22,24	9	9	15	9,5	5	30
	13	12	50,4	47	41	9	29,972	6,5	19,05	28,54	12	9	15	12,5	6,5	28
	16	12	53,5	50	41	9	31,75	6	19,05	31,74	13,5	9	15	14,5	7	28
	20	12	60,1	55	41	11	33,528	5	19,05	34,94	16,5	11	18	17,4	8	28
	25	12	69,7	63	41	14	40,64	7	23,82	39,68	22	13	20	22,2	9	28
	32	12	69,7	63	41	14	40,64	7	23,82	39,68	22	13	20	22,2	9	28
	40	12	76,4	73	41	14	43,993	10	27	48	26	13	20	26	10	28

Material	Hardness
Punch retainer 40CrMo8 T4 / 4140T	43 - 48 HRc

To order :
Punch retainers without shock plate
Qty = 3 RR-BLTN-16

RT-BLSN



Cut-away A-A

Cut-away B-B

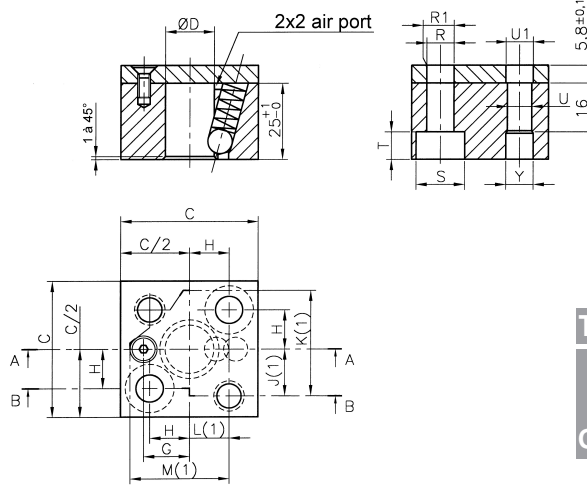

! Shock plate included

To order :

Qty = 3 RT-BLSN-20

Ref.	ØD H6	C ±0,25	G ±0,1	H ±0,1	J ±0,01	K ±0,01	L ±0,01	M ±0,01	R H13	R1 H13	S H13	T ±0,25	U G6	U1 H13	Y H13
RT-BLSN	10	45	15	13	15,5	28,5	13	26	9	9	16	9	8	9	9
	13	45	15	13	15,5	28,5	13	26	9	9	16	9	8	9	9
	16	45	15	13	15,5	28,5	13	26	9	9	16	9	8	9	9
	20	56	19	16	19	35	16	32	11	11	18	11	10	11	11
	25	63	22	20	22,5	42,5	20	40	14	14	20	13	10	11	11

RT-BLRN



Cut-away A-A

Cut-away B-B

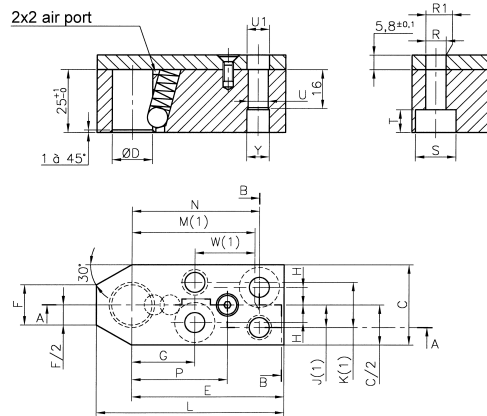

! Shock plate included

To order :

Qty = 3 RT-BLRN-20

Ref.	ØD H6	L ±0,25	C ±0,25	E ±0,2	F ±0,25	G ±0,1	H ±0,1	J ±0,01	K ±0,01	M ±0,01	W ±0,01	N ±0,1	P ±0,1	R H13	R1 H13	S H13	T ±0,25	U G6	U1 H13	Y H13
RT-BLRN	10	75	32	60	18	25	7	9	18	50	25	50	38	9	9	16	9	8	9	9
	13	75	32	60	18	25	7	9	18	50	25	50	38	9	9	16	9	8	9	9
	16	75	32	60	18	25	7	9	18	50	25	50	38	9	9	16	9	8	9	9
	20	85	40	63	20	28	9	11	22	53	25	53	41	11	11	18	11	10	11	11
	25	85	40	63	20	28	9	11	22	53	25	53	41	11	11	18	11	10	11	11

Material	Hardness
Punch retainer	43 - 48 HRc
Shock plate { 40CMB8 T4 / 4140T }	32 - 38 HRc

+ Ball-lock release tool for punches removal available page 38

RT-PPTS

For round shaped punches

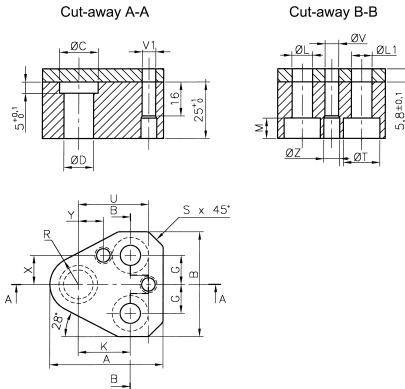

Shock plate included

To order :

Qty = 3 RT-PPTS - 20

Ref.	ØD G6	C ±0,25	A ±0,25	B ±0,25	R ±0,25	S ±0,25	G ±0,25	K ±0,25	Y ±0,01	U ±0,01	X ±0,01	V G6	L H13	T H13	M ±0,25	Z H13
RT-PPTS	8	12	44,5	38	9,5	5	10	21	9	29	10	6	9	16	9	7
	10	14	44,5	38	9,5	5	10	21	9	29	10	6	9	16	9	7
	13	17	50,5	47	12,5	6,5	13	23	11	32	13	6	9	16	9	7
	16	20	53,5	50	14	7	12	26	12	34	13	6	11	18	11	7
	20	25	60	55	17,5	8	14	27	11,5	34	17	8	11	18	11	9
	25	30	69,5	63	22	9	15	30	12	39	21	8	14	20	13	9
32	37	69,5	63	22	9	15	33	16,5	40	22	8	14	20	13	9	

RT-PPTF

For shaped punches

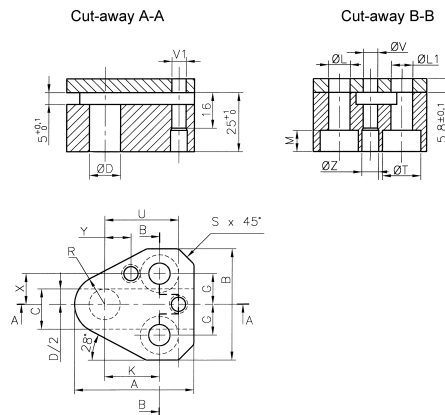

Shock plate included

To order :

Qty = 3 RT-PPTF - 20

Ref.	ØD G6	C ±0,25	A ±0,25	B ±0,25	R ±0,25	S ±0,25	G ±0,25	K ±0,25	Y ±0,01	U ±0,01	X ±0,01	V G6	L H13	T H13	M ±0,25	Z H13
RT-PPTF	8	11	44,5	38	9,5	5	10	21	9	29	10	6	9	16	9	7
	10	12	44,5	38	9,5	5	10	21	9	29	10	6	9	16	9	7
	13	17	50,5	47	12,5	6,5	13	23	11	32	13	6	9	16	9	7
	16	18,5	53,5	50	14	7	12	26	12	34	13	6	11	18	11	7
	20	23	60	55	17,5	8	14	27	11,5	34	17	8	11	18	11	9
	25	28,5	69,5	63	22	9	15	30	12	39	21	8	14	20	13	9
32	35	69,5	63	22	9	15	33	16,5	40	22	8	14	20	13	9	

Material	Hardness
Punch retainer	43 - 48 HRc
Shock plate { ⁴⁰ CMDB T4 / ⁴¹ 40T}	32 - 38 HRc

RT-PPSS

For round shaped punches

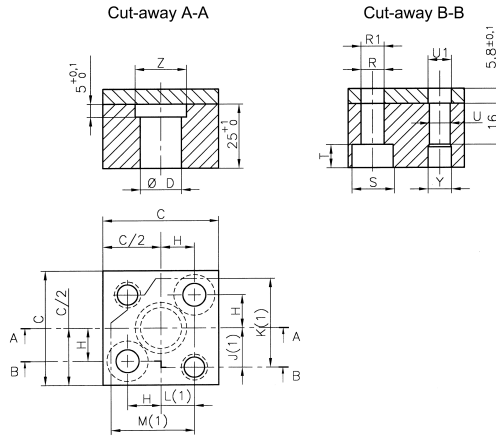

! Shock plate included

To order :

Qty = 3 RT-PPSS - 20

Reference	ØD G6	C ±0,25	H ±0,1	J ±0,01	K ±0,01	L ±0,01	M ±0,01	R H13	R1 H13	S H13	T ±0,25	U G6	U1 H13	Y H13	Z ±0,25
RT-PPSS	8	45	13	15,5	28,5	13	26	9	9	16	9	8	9	9	12
	10	45	13	15,5	28,5	13	26	9	9	16	9	8	9	9	14
	13	45	13	15,5	28,5	13	26	9	9	16	9	8	9	9	17
	16	45	13	15,5	28,5	13	26	9	9	16	9	8	9	9	20
	20	56	16	19	35	16	32	11	11	18	11	10	11	11	25
	25	63	20	22,5	42,5	20	40	14	14	20	13	10	11	11	30
	32	75	25	28	53	25	50	14	14	20	13	10	11	11	37

RT-PPSF

For shaped punches

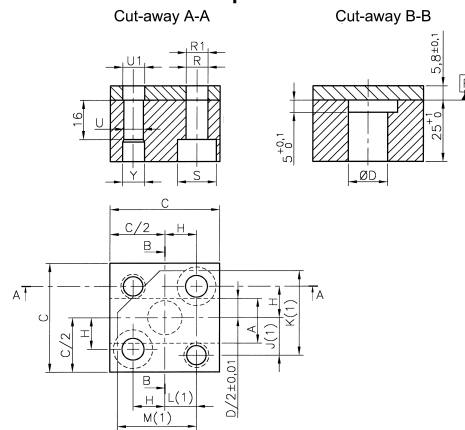

! Shock plate included

To order :

Qty = 3 RT-PPSF - 20

Ref.	ØD G6	A ±0,25	C ±0,25	H ±0,01	J ±0,01	K ±0,01	L ±0,01	M ±0,01	R H13	R1 H13	S H13	T ±0,25	U G6	U1 H13	Y H13	Z ±0,25
RT-PPSF	8	11	45	13	15,5	28,5	13	26	9	9	16	9	8	9	9	12
	10	12	45	13	15,5	28,5	13	26	9	9	16	9	8	9	9	14
	13	17	45	13	15,5	28,5	13	26	9	9	16	9	8	9	9	17
	16	18,5	45	13	15,5	28,5	13	26	9	9	16	9	8	9	9	20
	20	23	56	16	19	35	16	32	11	11	18	11	10	11	11	25
	25	28,5	63	20	22,5	42,5	20	40	14	14	20	13	10	11	11	30
	32	35	75	25	28	53	25	50	14	14	20	13	10	11	11	37

Material	Hardness
Punch retainer	43 - 48 HRc
Shock plate {40CMDB T4 / 4140T}	32 - 38 HRc

RT-PPRS

For round shaped punches

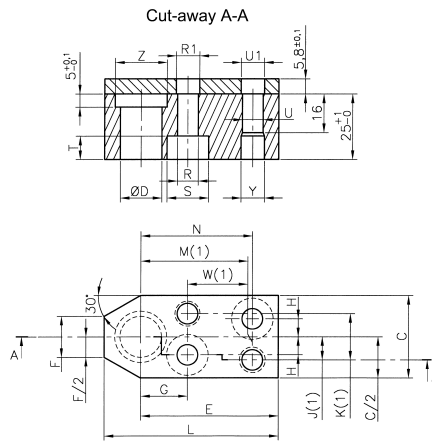

! Shock plate included

To order :

Qty = 3 RT-PPRS - 20

Ref.	ØD	L	C	E	F	G	H	J	K	M	W	N	R	R1	S	T	U	U1	Y	Z
	G6	±0,25	±0,25	±0,2	±0,25	±0,01	±0,1	±0,01	±0,01	±0,01	±0,01	±0,01	H13	H13	H13	±0,25	G6	H13	H13	±0,25
RT-PPRS	8	60	32	50	11	15	7	9	18	40	25	40	9	9	16	9	8	9	9	12
	10	60	32	50	11	15	7	9	18	40	25	40	9	9	16	9	8	9	9	14
	13	67	32	53	16	18	7	9	18	43	25	43	9	9	16	9	8	9	9	17
	16	67	32	53	16	18	7	9	18	43	25	43	9	9	16	9	8	9	9	20
	20	80	40	60	22	25	9	11	22	50	25	50	11	11	18	11	10	11	11	25
	25	80	40	60	22	25	9	11	22	50	25	50	11	11	18	11	10	11	11	30
	32	95	50	70	30	28	13	15	30	58	30	58	14	14	20	13	10	11	11	37

RT-PPRF

For shaped punches

Cut-away A-A

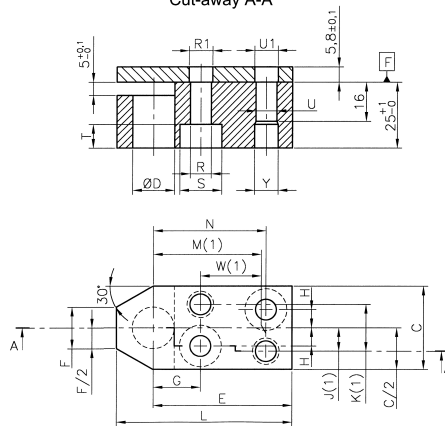

! Shock plate included

To order :

Qty = 3 RT-PPRF - 20

Ref.	ØD	L	C	E	F	G	H	J	K	M	W	N	R	R1	S	T	U	U1	Y	Z
	G6	±0,25	±0,25	±0,2	±0,25	±0,01	±0,1	±0,01	±0,01	±0,01	±0,01	±0,01	H13	H13	H13	±0,25	G6	H13	H13	±0,25
RT-PPRF	8	60	32	50	11	15	7	9	18	40	25	40	9	9	16	9	8	9	9	12
	10	60	32	50	11	15	7	9	18	40	25	40	9	9	16	9	8	9	9	14
	13	67	32	53	16	18	7	9	18	43	25	43	9	9	16	9	8	9	9	17
	16	67	32	53	16	18	7	9	18	43	25	43	9	9	16	9	8	9	9	20
	20	80	40	60	22	25	9	11	22	50	25	50	11	11	18	11	10	11	11	25
	25	80	40	60	22	25	9	11	22	50	25	50	11	11	18	11	10	11	11	30
	32	95	50	70	30	28	13	15	30	58	30	58	14	14	20	13	10	11	11	37

Material	Hardness
Punch retainer	43 - 48 HRc
Shock plate {40CMDB T4 / 4140T}	32 - 38 HRc

RZ-PPPH For shaped punches

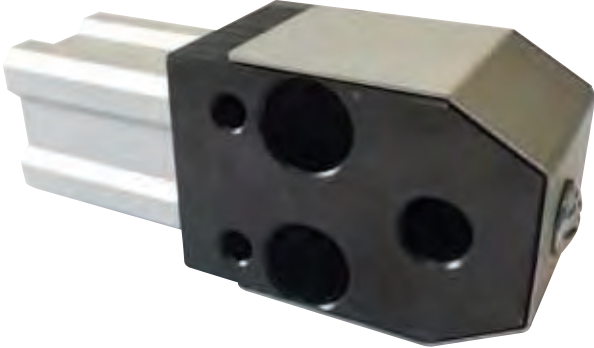

Retractable pneumatically controlled punch retainers are used when parts for different modes are manufactured on the same tool. A blade holds the punch in position and sets it back sufficiently to prevent contact with the material.

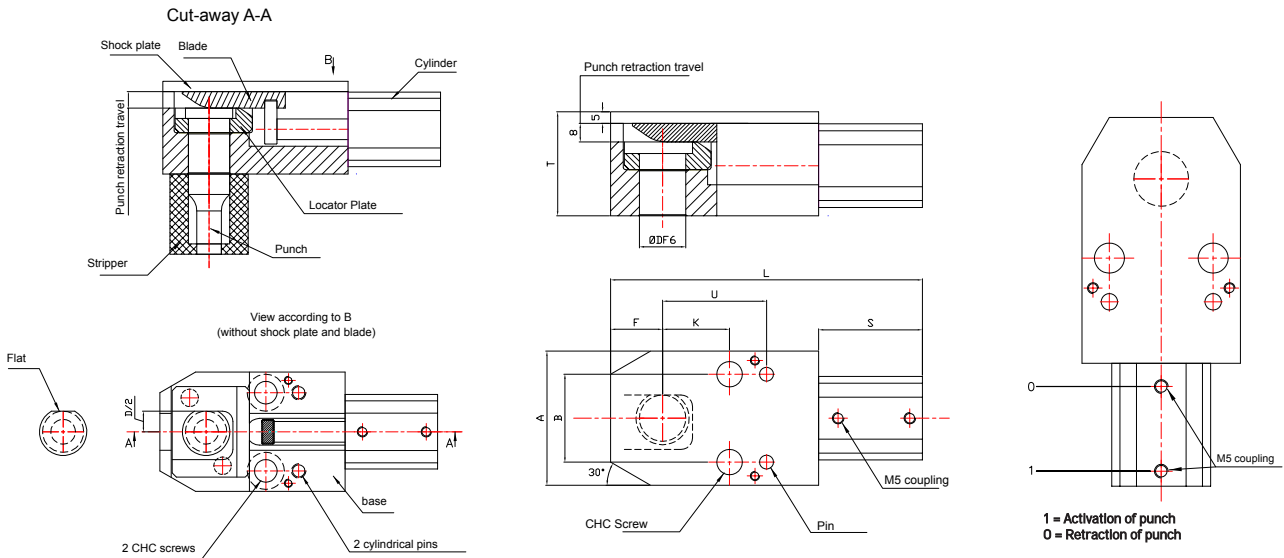

Retractable pneumatically controlled punch retainers can be used with P_ -PPN_ and P_ -PPE_ type punches (pages 01-04). If fitted with a stripper, make your choice according to the standard on page 33.



Connection to the compressed air system :
You must drill holes in the frame and discharge vents in the press. The pipes must be fixed to the bottom of the frame by clamps. Diameter of connection to cylinder : M5.
Accessories required for connection to the compressed air system are not supplied.
A flat location must be done on round shaped punches to allow the fitting in the orientation plate.

Reference	ØD	L	A	B	F	C	K	S	T	U	CHC screw	Pin
RZ-PPPH	10	117	46	30	17,5	72,5	25	44,5	45	41	M8x50	GT 6x32
	13	117	49	30	17,5	72,5	25	44,5	45	41	M10x50	GT 6x32
	16	117	49	30	17,5	72,5	25	44,5	45	41	M10x50	GT 6x32
	20	139,5	58	30	22,5	90	29	49,5	45	45	M10x50	GT 6x32
	25	139,5	58	38	22,5	90	29	49,5	45	45	M10x50	GT 6x32
	32	190,5	80	56	31	121	38	69,5	55	60	M12x60	GT 8x32
	40	190,5	80	56	31	121	38	69,5	55	60	M12x60	GT 8x32

To order :

Qty = 2 R Z - P P P H - 20

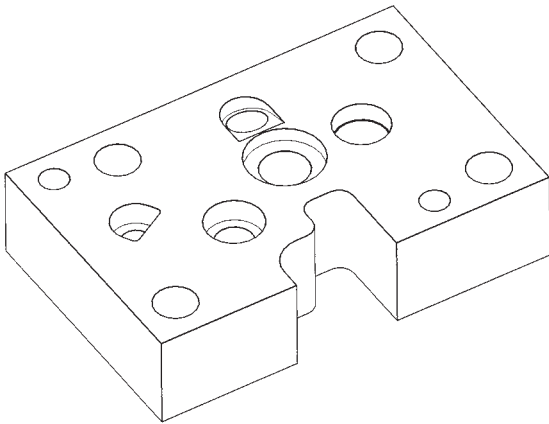

Cut away A-A

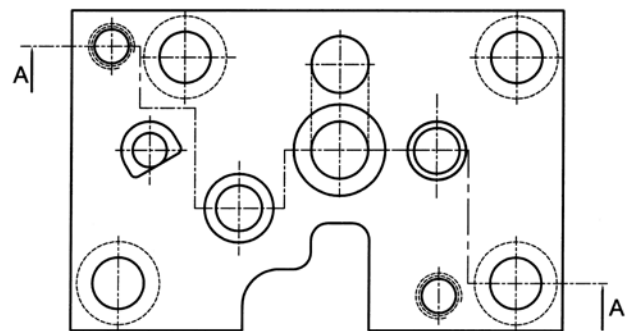
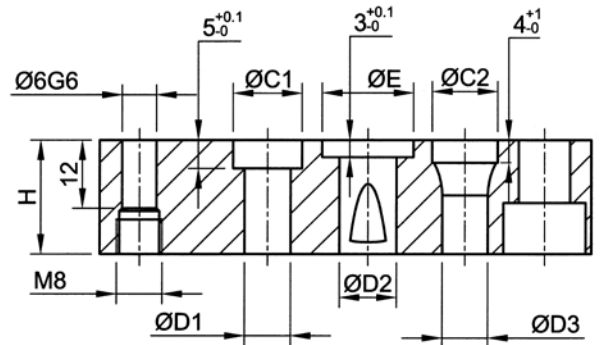

Dimensioning recommendations :

- Please use preferably the standard dimensions as specified in the below table. Other specifications are possible on request.
- The punch retainer positioning is carried out by ØG6 pin holes with a M8 thread for punch retainer.
- Shock plate can also be made according to special drawing.
- Specify the ball-lock punches preferences when ordering.
- For quotation, please send us the drawing of the requested punch retainer (DWG, STEP etc...).

Ball location (top view)

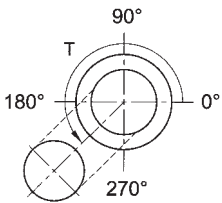

Antirotation position shaped punches with cylindrical head, conical head or tapered punches (top view)

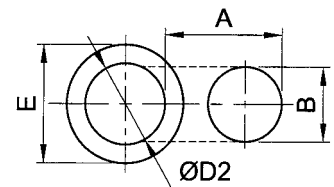
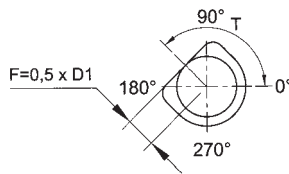

Headed punches			Ball-lock punches for light duty				Ball-lock punches for heavy duty				Tapered head punches				
ØD1	ØC1	H (recommended)	ØD2	ØE	H (recommended)	A	B	ØD2	ØE	H (recommended)	A	B	ØD3	ØC2	H (recommended)
5	9	25/32													
6	10	25/32											6	9,5	25
7	11	25/32											8	11,5	25
8	12	25/32											10	14,5	32
9	13	25/32													
10	14	25/32	10	14	32	14	10	10	14	41	16	12	10	14,5	32
11	15	25/32													
12	16	25/32													
13	17	25/32	13	17	32	14	10	13	17	41	18	14	13	17,5	32
14	18	25/32													
15	19	25/32													
16	20	25/32	16	20	32	14	10	16	20	41	18	14	16	20,5	32
20	25	25/32	20	25	32	14	10	20	25	41	18	14	20	25,5	41
25	30	25/32	25	30	32	14	10	25	30	41	18	14			
32	37	25/32						32	37	41	18	14			
40								40	45	41	18	14			

Material	Hardness
SAE 4140	43 - 48 HRc

To order :

Qty = 2 R R - X X X X - 10 - 14 - 25

SQUARE FOR DIES BUTTONS

RR-BLSN

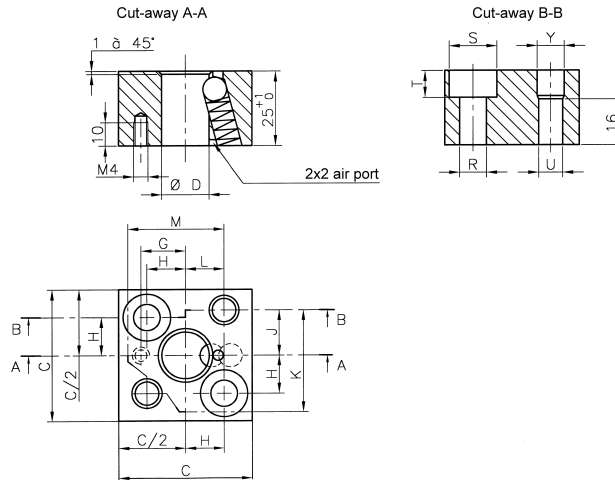

To order :
Die retainers without shock plate
Qty = 3 RR - BLSN - 20

Ref.	ØD H6	C ±0,25	G ±0,1	H ±0,1	J ±0,01	K ±0,01	L ±0,01	M ±0,01	R H13	S H13	T ±0,01	U ±0,25	Y H13
RR-BLSN	10	45	15	13	15,5	28,5	13	26	9	16	9	8	9
RR-BLSN	13	45	15	13	15,5	28,5	13	26	9	16	9	8	9
RR-BLSN	16	45	15	13	15,5	28,5	13	26	9	16	9	8	9
RR-BLSN	20	56	19	16	19	35	16	32	11	18	11	10	11
RR-BLSN	25	63	22	20	22,5	42,5	20	40	14	20	13	10	11
RR-BLSN	32	63	22	20	22,5	42,5	20	40	14	20	13	10	11
RR-BLSN	40	71	27	25	27,5	52,5	25	50	14	20	13	10	11

RR-BLRN

RECTANGULAR FOR DIES BUTTONS

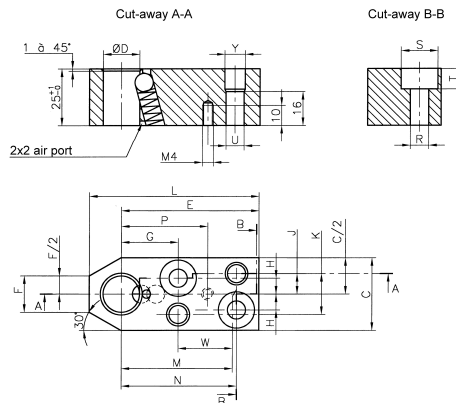

To order :
Die retainers without shock plate
Qty = 3 RR - BLRN - 20

Ref.	E H6	L ±0,25	C ±0,25	E ±0,2	F ±0,25	G ±0,1	H ±0,1	J ±0,01	K ±0,01	M ±0,01	W ±0,01	N ±0,1	P ±0,1	R H13	S H13	T ±0,25	U G6	Y H13
RR-BLRN	10	75	32	60	18	25	7	9	18	50	25	50	38	9	16	9	8	9
RR-BLRN	13	75	32	60	18	25	7	9	18	50	25	50	38	9	16	9	8	9
RR-BLRN	16	75	32	60	18	25	7	9	18	50	25	50	38	9	16	9	8	9
RR-BLRN	20	85	40	63	20	28	9	11	22	53	25	53	41	11	18	11	10	11
RR-BLRN	25	85	40	63	20	28	9	11	22	53	25	53	41	11	18	11	10	11
RR-BLRN	32	100	56	72	24	30	14	17	34	55	25	55	43	11	18	11	10	11

Material	Hardness
SAE 4140	43 - 48 HRc

Ball-lock release tool for punches removal available page 80
Dimensions without tolerance ±0,25 mm.

MADE FROM STANDARDISED PUNCHES AND DIES



Shapes and dimensions to be precised as per table on page 47

We are also at your disposal to produce punches and dies according to your drawing.
Price and lead times on request.

Comment 1:

- 1 Mln. radius of 0.2mm can be done on the punch
- 2 Mln. radius of 0.2mm can be done on the die

Comment 2:
Punch and die reading direction according to the drawing below.

Comment 3:
To ensure correct operation between punch and die, do not forget to specify the clearance J per face.

Order example 1

Ball-lock punch :
TMX64 type PB-BLNT
Ø13 mm - length L1 = 71mm - material B
P=8.63 - W=4.13 - L2=16mm - T90°

Ball-lock die :
TMX64 type DA-BLCT
Ø16 mm - height 32mm -
Working length 5mm
P=8.69 - W=4.19 - T90°

Standard orientation of the ball indentation is 90° as shown opposite. Other orientation on request.

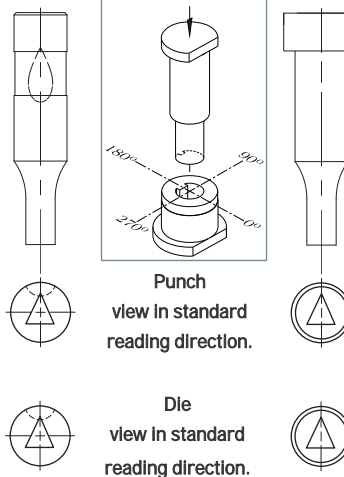

Order example 2

Headed punch :
TMX64 type PB-PPNT
Ø10 mm - length L1 = 80mm - material B
P=7.52 - W=3.56 - L2=13mm - T0°

Headed die :
TMX64 type DA-HHCT
Ø16 mm - height 32mm -
Working length 5mm
P=7.62 - W=3.66 - T0°

Standard flat location is at T = 0° as shown opposite. Other location on request.

TMX type - Convex shape

90°

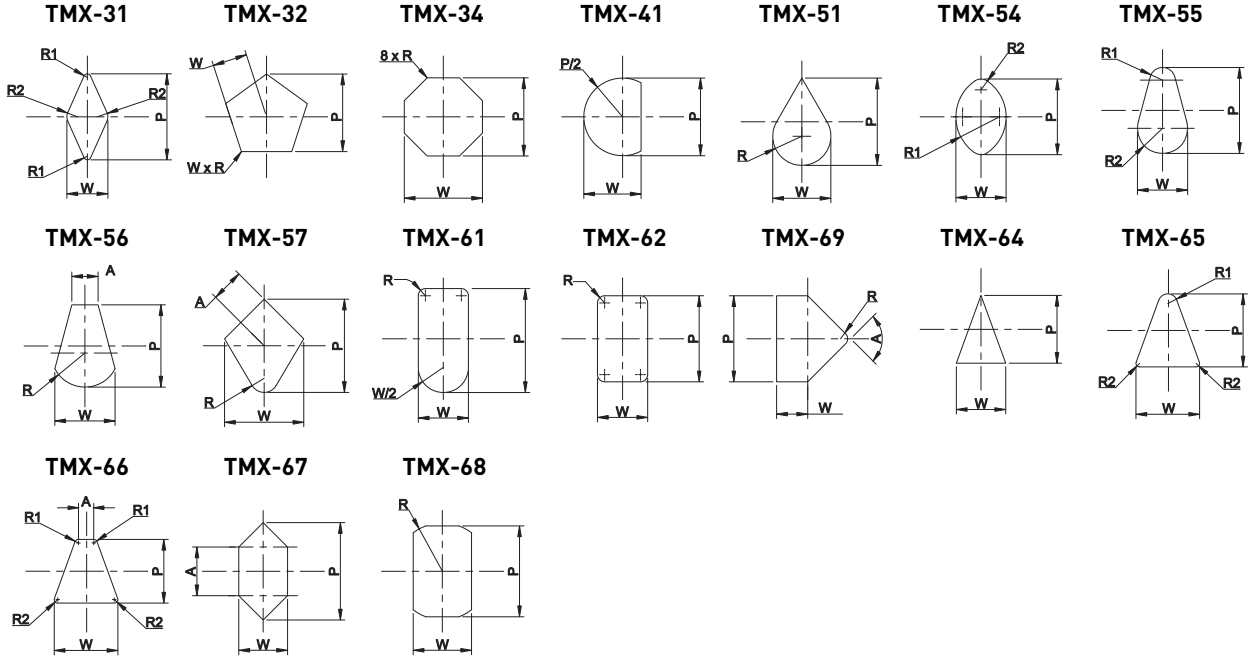

180°

0°

TMX type - Convex shape

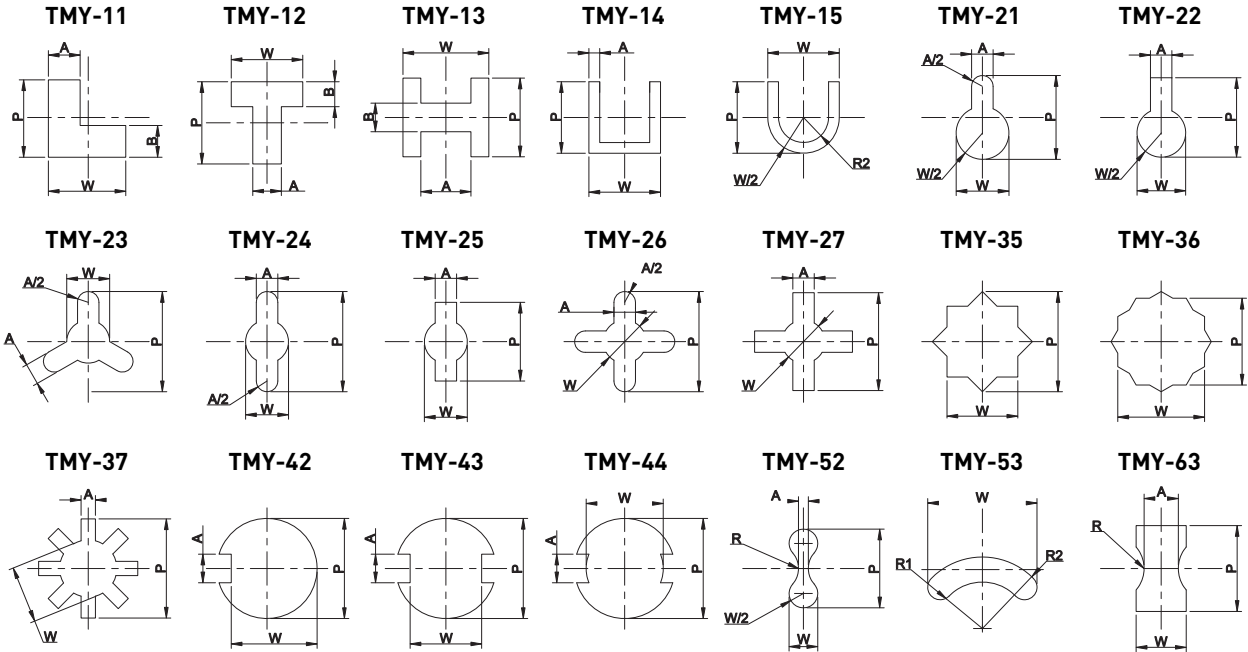

270°

 Punch flat location page 48
Die flat location page 51

 Views of the head side for punches and cutting face for dies.

To order :

Punch H55 ISO 80/20 Solid TMX shape D body L1 L2 Shape dimensions Flat Position Shaped
P B - P P N T - 16 - 71 - 20 - P9.2 - W5.2 - R2 - T90 - TMX64

 Shapes
(TMY) = E
(TMX) = T
(SPECIALS) = X

FLAT LOCATION:

Tangent flat

Double tangent flat

Through flat (a)

Double through flat

Special flat (b)

R2

R2 (2x)

R84

R84 (2x)

R89

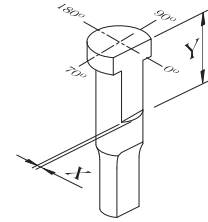
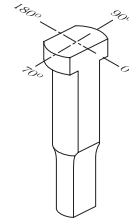
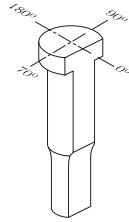
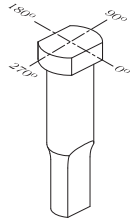
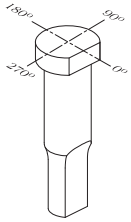

(a) Specify depth by X =

(b) Specify depth by X = and length by Y =

To order :

Qty = 2

PB-PPNR-16-71-20-P7.2-W6.2-R2-T0

DOWEL LOCATION:

HEADED PUNCHES

Code Ø P

R0 P = 3

R4 P = 3

R41 P = 4

R43 P = 6

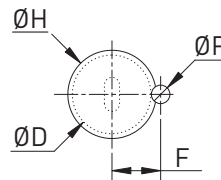
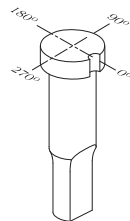

$$F = 0,5 * D + 0,5 * P$$

Ø D = Ø Body

Ø P = Ø Dowel pins

Ø H = Ø Head



ØP (dowel pins) tangent to ØD (body).

To order :

Qty = 2

PB-PPNR-16-71-20-P7.2-W6.2-R0-T0

OPTIMIZATION :

Polishing the cutting part

Code

TP

Cutting part relief

PT

Chamfering of cutting edges

Manual chamfering R0,1 to R0,3

TR

Vent hole removal
(For ejector punches)

GA

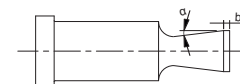

PB-PPNL-16-71-20-P9-W7-PT2-3

2° relief with 3mm straight section

TOLERANCE MODIFICATIONS

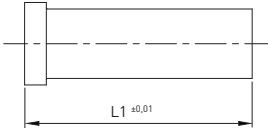
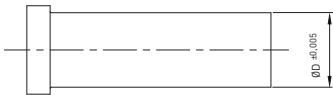
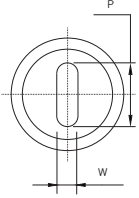
Type Code	Length L1	Body diameter	P and W shape dimensions
	AL	AD	AP_
Drawings			
Example	PB-PPNA-16-71-AL Tolerance $\pm 0,01$ on length L1	PB-PPNA-16-71-AD Tolerance $\pm 0,005$ on body diameter	PB-PPNL-16-71-20-P9-W7-AP1 AP1 : tol. $\pm 0,005$ on P and W AP2 : tol. $\pm 0,001/0$ on P and W AP3 : tol. $0/0,01$ on P and W

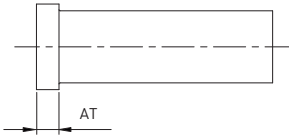
Type Code	Head thickness
	AT_
Drawings	
Example	PB-PPNA-16-71-AT2
Type	AT1 $\pm 0,01$ Tolerance $\pm 0,01$ on head thickness AT2 $\pm 0/-0,05$ Tolerance $\pm 0/-0,05$ on head thickness

DIMENSIONAL MODIFICATIONS

Type	Head thickness	Head diameter	Head chamfering	Connecting radius
Code	MT	PH	PC	MR
Drawings				
Example	PB-PPNB-16-71-MT4	PB-PPNA-16-71-PH18	PB-PPNA-16-71-PC0,5-45	PB-PPNS-20-80-19-P17-MR2



Regaining the thickness head by grinding the upper surface result in a reduction of the length L1

Head diameter reduction at 18mm (19mm in standard)

(CH 0,5 x 45°)

(Radius R = 2 instead of 10 +3/0 in standard.)

SHEAR ANGLES

Type	ROUNDS + SHAPES			
	1 shear	2 shears	2 negativ shears	Radius
Code	KS	KF	KY	KR
Drawings				
Example	KS2-0.5 Shear a=2° with flat b=0.5mm	KF3-1 2 Shears a=3° with flat b=1mm	KY5-1 2 Shears a=5° with flat b=1mm	KR15-1 Radius R15 with flat b=0.5mm



The shear is made in the direction of the dimensions P for the shear angles KS, KF, KY and KR.

Type	ROUNDS ONLY		
	3 shears	4 shears	Conical
Code	KM	KN	KC
Drawings			
Example	KM5-0 3 Shears a=5° without flat	KN2-0 4 Shears a=2° without flat	KC30-3 Cone a=2° with flat b=3MM

FLAT LOCATION:

Headed dies

Tangent flat

R2

Double tangent flat

R2 (2x)

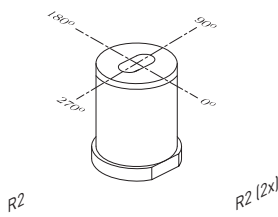

Straight dies

5mm x 1.5mm flat

R2

14mm height flat

R20 - R80

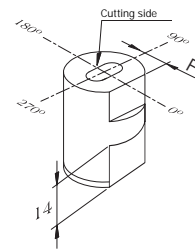
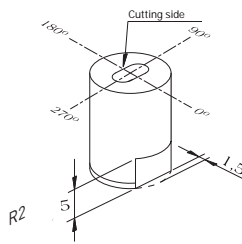

R80

R80 = Cutting side

R20 = Flat at the bottom

R20

Ø Body	06	08	10	13	16	20	22	25	32	38
F	2,6	3,5	4	5,5	7	8,5	9,5	11	14	17
Ø Body	40	45	50	56	63	71	76	85	90	100
F	18	20,5	23	26	29,5	33,5	35,5	40	42,5	47,5

To order :

Qty = 1

DB-SMCR-20-32-8-P8-W4-R2-T90

ALL TYPES OF DIES

R84

Through flat

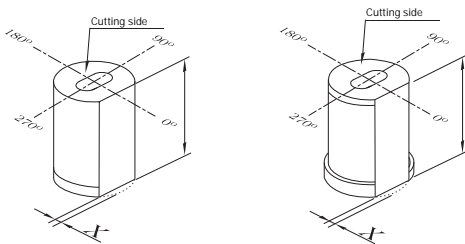

X = Flat depth based on the body Ø

R89

Special flat (b)

(b) Precise depth by X = length by Y =

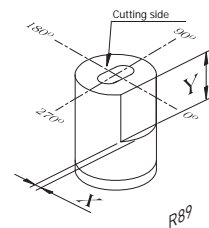

To order :

Qty = 1

DA-SMDL-16-25-5-P9-W6-R89X1.2Y15-T0

DOWEL LOCATION:

Headed dies

Code	Ø P
R0	P = 3
R4	P = 3
R41	P = 4
R43	P = 6

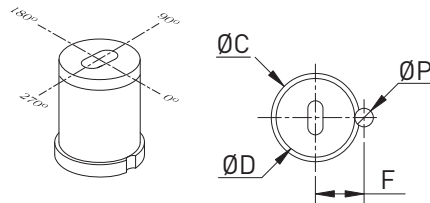

$$F = 0,5 * D + 0,5 * P$$

Ø D = Ø Body

Ø P = Ø Dowel pins

Ø H = Ø Head



ØP (dowel pins) tangent to ØD (body).

To order :

Qty = 2

DA-HMDL-16-25-5-P9-W6-R0-T0

Straight dies

Code	Ø P	Ø 6	Ø 8	Ø 10	Ø 13	Ø 16 - 25	Ø 32 - 100
R0	P = 3	F=0,5*D	F=0,5*D	F=0,5*D	F=0,5*D	F=0,5*D	F=0,5*D
R4	P = 3	F=3,9	F=4,7	F=5,5	F=6,7	F=0,5*D	F=0,5*D
R41	P = 4	F=4,4	F=5,2	F=6,0	F=7,2	F=0,5*D	F=0,5*D
R43	P = 6	F=5,4	F=6,2	F=7,0	F=8,2	F=0,5*D+1,0	F=0,5*D

Ø D = Ø Body

Ø P = Ø Dowel pins

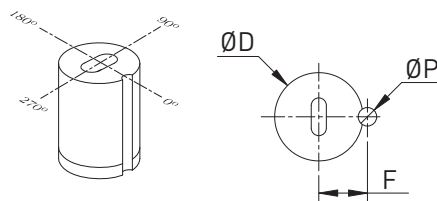

To order :

Qty = 3

DA-SMDL-16-25-5-P9-W6-R4-T0

WASTE RETENTION:

Waste retention | GX

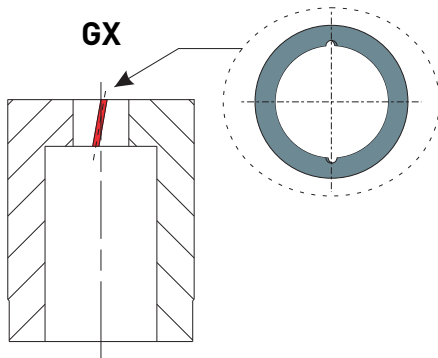

Principle : Thin grooves are machined at opposite angles into the cutting shape.

This generates small protuberances in the waste which hold it in the die.



Others options can be recommended on request to prevent the rising from the waste.

TOLERANCE MODIFICATIONS

Type Code	Length L1	Body diameter	P and W shape dimensions
	AL	AD	AP_
Drawings			
Example	DA-HMCA-20-25-5-AL Tolerance $\pm 0,01$ on length L1	DA-HMCS-20-32-8-AD Tolerance $\pm 0,005$ on body diameter	DB-HMCL-32-32-8-P16-W8-AP AP1 : tol. $\pm 0,005$ on P and W AP2 : tol. $\pm 0,001/0$ on P and W AP3 : tol. $0/0,01$ on P and W

DIMENSIONAL MODIFICATIONS

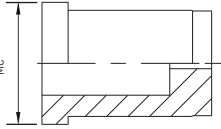
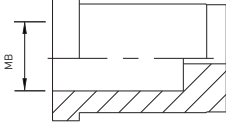
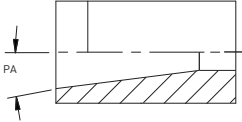
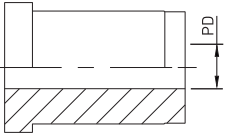
Type	Collar diameter reductions	Relief diameter	Tapered relief angle	Straight relief on the length
Code	MC	MB	PA	PD
Drawings				
Example	DB-HMCA-20-25-5-MC22 Collar Ø22	DA-HMCA-20-32-5-MB15 Relief Ø15	DA-HMDS-16-25-5-P6,3-PA2 Relief angle 2°	DA-HMDS-20-25-25-P8,2-PD

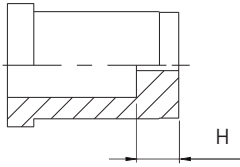
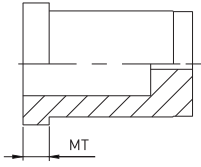
Type	Working height	Collar thickness reduction
Code		MT
Drawings		
Example	DA-HMCA-20-25-4 Height H changed to H = 4mm	DA-HMCA-20-25-5-MT4



Head thickness reduction by grinding of the upper side resulting in a reduction in length L1

COATINGS :

The standard coatings proposed are shown in the table below.

Coating	TiN	TiCN	CrN	AlCrN	t - ac
Microhardness (HV0,05)	2300	3000	1750	3200	5000
Thickness (micrometer)	2 to 4	2 to 4	2 to 4	2 to 4	1,5 to 3
Color	Yellow gold	Blue grey	Silver grey	Blue grey	Black
Applications	Cutting steel with low mechanical properties	Stainless steel cutting	Cutting copper alloys	High yield strength steel cutting	Cutting aluminium and composites



Other coatings available on request.

Note : The coatings can significantly improve the cutting process. Do not hesitate to ask us.

CUTTING CLEARANCE :

Materials	Tight clearance	Medium clearance	Recommended clearance	Large clearance
Aluminium	1 - 2%	4 - 8%	12 - 15%	16 - 20%
Stainless steel	2 - 4%	6 - 10%	18 - 22%	25 - 27%
Mild steel	2 - 4%	10 - 14%	16 - 20%	15 - 23%
High yield strength steel	5 - 10%	22 - 25%	26 - 32%	33 - 36%

*Diameter clearance value

RECOMMANDATIONS

- The function of the cutted shape is an important info to define the clearance value between the punch and the die.
- If no precision is required, the lifespan of the punches and dies can be significantly increased by using a large clearance.
- If precise profil specifications and a sheared height greater than 50% of the sheet thickness are required, a tight clearance between the punch and the die is recommended.
- A precise alignment between the punch and die is essential to ensure a precise cutting and the lifespan of the tools.
- The dimensions of the cutted shape is defined by the punch, the dimensions of the waste (slug) by the die.
- In the case of "recommended clearance" or "large clearance", it may be recommended to use ejector punches.



AMDL
www.amdl-eu.com

AMDL

AMDL SCOP SA
Aire d'activité du Florival
9 rue de l'Oberwald
FR-68500 ISSENHEIM
Tél : +33 (0)3 89 74 24 24
contact@amdl-eu.com

